

**LECTURES IN GENERAL PHYSICS**

# *Electrostatic*

*Principles and Applications*

Dr. Hazem Falah Sakeek

Al-Azhar University - Gaza

*Part Two*

# LECTURES IN GENERAL PHYSICS

Part Two

# Electrostatic

Principles and Applications

**Dr. Hazem Falah Sakeek**  
Associated Professor of Physics  
Al-Azhar University – Gaza



March 2001



## Lecture in General Physics

First Edition, 2001.

All Rights Reserved. No part of this book may be reproduced, stored in a retrieval system, or transmitted, in any form or by any means, electronic, mechanical, photocopying, recording or otherwise, without the prior permission of the publisher.

محاضرات في الفيزياء العامة

الطبعة الأولى، 2001.

جميع حقوق الطبع محفوظة. غير مسموح بطبع أي جزء من أجزاء هذا الكتاب، أو خزنه في أي نظام لخرن المعلومات واسترجاعها، أو نقله على أية هيئة أو بأية وسيلة سواء كانت إلكترونية أو شرائط ممغنطة أو ميكانيكية، أو استنساخاً أو تسجيلاً أو غيرها إلا بإذن كتابي من صاحب حق الطبع.

# محاضرات في الفيزياء العامة

## الجزء الثاني

# الكهربية الساكنة

## أساسيات وتطبيقات

د.حازم فلاح سكيك  
أستاذ الفيزياء المشارك  
جامعة الأزهر-غزة

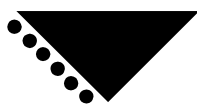

مارس 2001

## المقدمة

منذ نشأة الخليقة على سطح الأرض شرع الإنسان يتساءل عن كيفية وجود الأشياء وعن سبب وجودها. هذا التساؤل كان دافعه الطبيعة الفضولية لدى البشر الذين متعهم الله بنعمة العقل والتفكير. ولكن بسبب جهل الإنسان القديم وخوفه فإنه كان يعزو ظواهر الطبيعة إلى وجود قوى خارقة مجهولة، فعبدها ظاناً أنها المسئولة عن بقائه. ولكن مع مزيد من الملاحظات والاكتشافات ودافع الحاجة إلى الاختراع والابتكار أدرك أن الطبيعة تحكمها قوانين مترابطة تربط بين نشاطاته كإنسان وعلاقته بالعالم الجامد والعالم الحي على حد سواء. وعلم الفيزياء هو من العلوم التي تهتم بدراسة هذه القوانين وتسخيرها لخدمة البشرية. وفي أجزاء كتاب "محاضرات في الفيزياء العامة" سنتناول جزءاً أساسياً من علم الفيزياء التي يدرسها الطالب في المرحلة الجامعية.

الجزء الثاني من كتاب محاضرات في الفيزياء العامة يتناول شرح مبادئ الكهربية الساكنة وتطبيقاتها. وقد راعيت في عرض الموضوعات سهولة العبارة ووضوح المعنى. وتم التركيز على حل العديد من الأمثلة بعد كل موضوع لمزيد من التوضيح على ذلك الموضوع، وفي نهاية كل فصل تم حل العديد من المسائل المتنوعة التي تغطي ذلك الفصل، هذا بالإضافة إلى المسائل في نهاية كل فصل للطالب ليحلها خلال دراسته. تم الاعتماد على اللغة العربية وخصوصاً في الفصول الأربعة الأولى في توضيح بعض المواضيع وكذلك في التعليق على حلول الأمثلة وللاستفادة من هذا الكتاب ينصح باتباع الخطوات التالية:

- ☞ حاول حل الأمثلة المحولة في الكتاب دون الاستعانة بالنظر إلى الحل الموجود.
- ☞ اقرأ صيغة السؤال للمثال المحلول عدة مرات حتى تستطيع فهم السؤال جيداً.
- ☞ حدد المعطيات ومن ثم المطلوب من السؤال.
- ☞ حدد الطريقة التي ستوصلك إلى إيجاد ذلك المطلوب على ضوء المعطيات والقوانين.
- ☞ قارن حلك مع الحل الموجود في الكتاب مستفيداً من أخطائك.

يحتوي الكتاب على ثمانية فصول، خصصت الفصول الخمسة الأولى منها لغرض المفاهيم الأساسية للكهربية الساكنة والتي هي القوى الكهربية والمجال الكهربي والجهد الكهربي ومن خلال قانون كولوم وقانون جاوس سنتمكن من إيجاد القوى الكهربية المتبادلة بين الشحنات وحساب المجال الكهربي الناتج من شحنة أو مجموعة من الشحنات (سواءً ذات توزيع منفصل أو متصل). وخصصت الفصول الثلاثة الباقية للتطبيقات المعتمدة على الكهربية الساكنة مثل المكثف الكهربي ودوائر التيار المستمر.

أمل أن أكون قد قدمت لأبنائنا الدارسين من خلال هذا العمل المتواضع ما يعينهم على فهم واستيعاب هذا الفرع من فروع المعرفة.

والله من وراء القصد

د. حازم فلاح سكيك

جامعة الأزهر - غزة

مارس 2001

# Contents

---

## Chapter (1) Electrostatic

1.1 Understanding Static Electricity	5
1.2 Properties of electrostatic	9
1.2.1 Electric charge	9
1.2.2 Conductor and insulator	9
1.2.3 Positive and negative charge	10
1.2.4 Charge is conserved	11
1.2.5 Charge and matter	11
1.2.6 Charge is Quantized	12

---

## Chapter (2) Coulomb's law

2.1 Coulomb's Law	16
2.2 Calculation of the electric force	17
2.2.1 Electric force between two electric charges	17
2.2.2 Electric force between more than two electric charges	18
2.3 Problems	27

---

## Chapter (3) Electric field

3.1 The Electric Field	32
3.2 Definition of the electric field	32
3.3 The direction of $\vec{E}$	33
3.4 Calculating $\vec{E}$ due to a charged particle	33
3.5 To find $\vec{E}$ for a group of point charge	34
3.6 Electric field lines	38
3.7 Motion of charge particles in a uniform electric field	39
3.8 Solution of some selected problems	40
3.9 The electric dipole in electric field	48
3.10 Problems	49

---

---

## Chapter (4) Electric Flux

4.1 The Electric Flux due to an Electric Field	54
4.2 The Electric Flux due to a point charge	57
4.3 Gaussian surface	57
4.4 Gauss's Law	58
4.5 Gauss's law and Coulomb's law	59
4.6 Conductors in electrostatic equilibrium	60
4.7 Applications of Gauss's law	62
4.8 Solution of some selected problems	69
4.9 Problems	76

---

---

## Chapter (5) Electric Potential

5.1 Definition of electric potential difference	84
5.2 The Equipotential surfaces	85
5.3 Electric Potential and Electric Field	86
5.4 Potential difference due to a point charge	90
5.5 The potential due to a point charge	91
5.6 The potential due to a point charge	92
5.7 Electric Potential Energy	95
5.8 Calculation of $E$ from $V$	97
5.9 Solution of some selected problems	98
5.10 Problems	107

---

---

## Multiple Choice Questions 110

---

## Chapter (6) Capacitors

6.1 Capacitor	125
6.2 Definition of capacitance	125
6.3 Calculation of capacitance	126
6.3.1 Parallel plate capacitor	126
6.3.2 Cylindrical capacitor	128
6.3.3 Spherical Capacitor	128
6.4 Combination of capacitors	129
6.4.1 Capacitors in parallel	129
6.4.2 Capacitors in series	130

4.5 Energy stored in a charged capacitor (in electric field)	135
6.6 Capacitor with dielectric	145
6.7 Problems	149

---



---

## Chapter (7) Current and Resistance

7.1 Current and current density	156
7.2 Definition of current in terms of the drift velocity	157
7.3 Definition of the current density	157
7.4 Resistance and resistivity (Ohm's Law)	159
7.5 Evaluation of the resistance of a conductor	160
7.6 Electrical Energy and Power	163
7.7 Combination of Resistors	165
7.7.1 Resistors in Series	165
7.7.2 Resistors in Parallel	166
7.8 Solution of some selected problems	171
7.9 Problems	177

---



---

## Chapter (8) Direct Current Circuits

8.1 Electromotive Force	182
8.2 Finding the current in a simple circuit	183
8.3 Kirchhoff's Rules	187
8.4 Single-Loop Circuit	190
8.5 Multi-Loop Circuit	195
8.6 RC Circuit	205
8.6.1 Charging a capacitor	205
8.6.2 Discharging a capacitor	207
8.7 Electrical Instruments	213
8.7.1 Ammeter and Voltmeter	213
8.7.2 The Wheatstone Bridge	214
8.7.3 The potentiometer	215
8.7 Problems	216

---



---

## Multiple Choice Questions 220

---



---



---

## Appendices

<b>Appendix (A):</b> Some practical application of electrostatic	230
Understanding the Van de Graaff generator	231
Cathode Ray Oscilloscope	234
XEROGRAPHY (Photocopier)	236
Battery	238
<b>Appendix (B):</b> Answer of Some Selected Problems	243
<b>Appendix (C):</b> The international system of units (SI)	246
<b>Appendix (D):</b> Physics Resources on the Web	254
<b>Appendix (E):</b> Bibliography	260
<b>Appendix (F):</b> Index	262

**LECTURES IN GENERAL PHYSICS**

# *Electrostatic*

*Principles and Applications*

Dr. Hazem Falah Sakeek

Al-Azhar University - Gaza

*Part Two*

# Part 1

## Principle of Electrostatic



# Chapter 1

## *Introduction to Electrostatic*



# **Introduction to Electrostatic**

## **1.1 Understanding Static Electricity**

## **1.2 Properties of electrostatic**

1.2.1 Electric charge

1.2.2 Conductor and insulator

1.2.3 Positive and negative charge

1.2.4 Charge is conserved

1.2.5 Charge and matter

1.2.6 Charge is Quantized

# Introduction to Electrostatic

## مقدمة عن علم الكهربية الساكنة



600



We have all seen the strange device, known as a *Van De Graaff Generator*, that makes your hair stand on end. The device looks like a big aluminum ball mounted on a pedestal, and has the effect pictured on the right. Have you ever wondered what this device is, how it works, why it was invented, Surely it wasn't invented to make children's hair stand on end... Or have you ever shuffled your feet across the carpet on a dry winter day and gotten the shock of your life when you touched something metal? Have you ever wondered about static electricity and static cling? If any of these questions have ever crossed your mind, then here we will be amazingly interesting as we discuss Van de Graaff generators and static electricity in general.



### 1.1 Understanding Static Electricity

To understand the Van de Graaff generator and how it works, you need to understand static electricity. Almost all of us are familiar with static electricity because we can see and feel it in the winter. On dry winter days, static electricity can build up in our bodies and cause a spark to jump from our bodies to pieces of metal or other people's bodies. We can see, feel and hear the sound of the spark when it jumps.

In science class you may have also done some experiments with static electricity. For example, if you rub a glass rod with a silk cloth or if you rub a piece of amber with wool, the glass and amber will develop a static charge that can attract small bits of paper or plastic.

To understand what is happening when your body or a glass rod develops a static charge, you need to think about the atoms that make up everything we can see. All matter is made up of atoms, which are themselves made up of charged particles. Atoms have a nucleus consisting of neutrons and protons. They also have a surrounding "shell" which is made up electrons. Typically matter is neutrally charged, meaning that the number of electrons and protons are the same. If an atom has more electrons than protons, it is negatively charged. Likewise, if it has more protons than electrons, it is

positively charged. Some atoms hold on to their electrons more tightly than others do. How strongly matter holds on to its electrons determines its place in the **Triboelectric Series**. If a material is more apt to give up electrons when in contact with another material, it is more positive on the Triboelectric Series. If a material is more to "capture" electrons when in contact with another material, it is more negative on the Triboelectric Series.

The following table shows you the Triboelectric Series for many materials you find around the house. Positive items in the series are at the top, and negative items are at the bottom:

- Human Hands (usually too moist though) (very positive)
- Rabbit Fur
- Glass
- Human Hair
- Nylon
- Wool
- Fur
- Lead
- Silk
- Aluminum
- Paper
- Cotton
- Steel (neutral)
- Wood
- Amber
- Hard Rubber
- Nickel, Copper
- Brass, Silver
- Gold, Platinum
- Polyester
- Styrene (Styrofoam)
- Saran Wrap
- Polyurethane
- Polyethylene (like scotch tape)
- Polypropylene
- Vinyl (PVC)
- Silicon
- Teflon (very negative)

The relative position of two substances in the Triboelectric series tells you how they will act when brought into contact. Glass rubbed by silk causes a charge separation because they are several positions apart in the table. The



same applies for amber and wool. The farther the separation in the table, the greater the effect.

When two non-conducting materials come into contact with each other, a chemical bond, known as adhesion, is formed between the two materials. Depending on the triboelectric properties of the materials, one material may "capture" some of the electrons from the other material. If the two materials are now separated from each other, a charge imbalance will occur. The material that captured the electron is now negatively charged and the material that lost an electron is now positively charged. This charge imbalance is where "static electricity" comes from. The term "static" electricity is deceptive, because it implies "no motion", when in reality it is very common and necessary for charge imbalances to flow. The spark you feel when you touch a doorknob is an example of such flow.

You may wonder why you don't see sparks every time you lift a piece of paper from your desk. The amount of charge is dependent on the materials involved and the amount of surface area that is connecting them. Many surfaces, when viewed with a magnifying device, appear rough or jagged. If these surfaces were flattened to allow for more surface contact to occur,

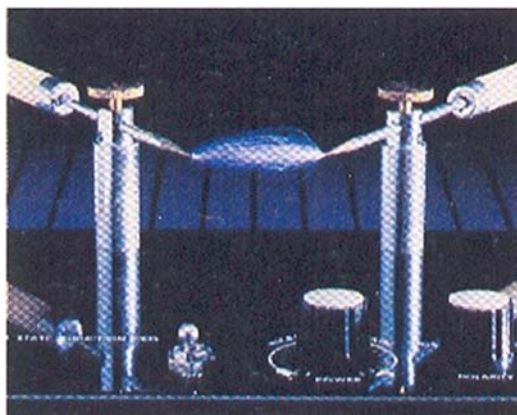

the charge (voltage) would most definitely increase. Another important factor in electrostatics is humidity. If it is very humid, the charge imbalance will not remain for a useful amount of time. Remember that humidity is the measure of moisture in the air. If the humidity is high, the moisture coats the surface of the material providing a low-resistance path for electron flow. This path allows the charges to "recombine" and thus neutralize the charge imbalance. Likewise, if it is very dry, a charge can build up to extraordinary levels, up to tens of thousands of volts!

Think about the shock you get on a dry winter day. Depending on the type of sole your shoes have and the material of the floor you walk on, you can build up enough voltage to cause the charge to jump to the doorknob, thus leaving you neutral. You may remember the old "Static Cling" commercial. Clothes in the dryer build up an electrostatic charge. The dryer provides a

low moisture environment that rotates, allowing the clothes to continually contact and separate from each other. The charge can easily be high enough to cause the material to attract and "stick" to oppositely charged surfaces (your body or other clothes in this case). One method you could use to remove the "static" would be to lightly mist the clothes with some water. Here again, the water allows the charge to leak away, thus leaving the material neutral.

It should be noted that when dirt is in the air, the air will break down much more easily in an electric field. This means that the dirt allows the air to become ionized more easily. Ionized air is actually air that has been stripped of its electrons. When this occurs, it is said to be **plasma**, which is a pretty good conductor. Generally speaking, adding impurities to air improves its conductivity. You should now realize that having impurities in the air has the same effect as having moisture in the air. Neither condition is at all desirable for electrostatics. The presence of these impurities in the air, usually means that they are also on the materials you are using. The air conditions are a good gauge for your material conditions, the materials will generally break down like air, only much sooner.

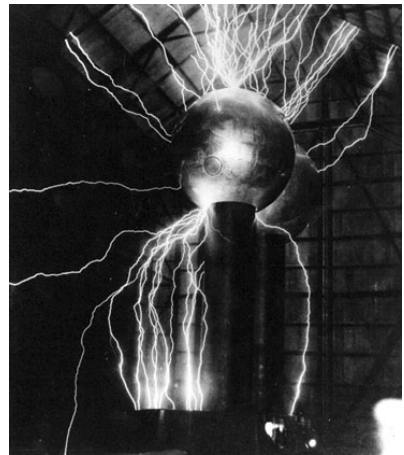

[Note: Do not make the mistake of thinking that electrostatic charges are caused by friction. Many assume this to be true. Rubbing a balloon on your head or dragging your feet on the carpet will build up a charge. Electrostatics and friction are related in that they both are products of adhesion as discussed above. Rubbing materials together can increase the electrostatic charge because more surface area is being contacted, but friction itself has nothing to do with the electrostatic charge]

*For further information see appendix A (Understanding the Van de Graaff generator)*

## 1.2 Properties of electrostatic

### 1.2.1 Electric charge

If a rod of ebonite is rubbed with fur, or a fountain pen with a coat-sleeve, it gains the power to attract light bodies, such as pieces of paper or tin foil. The discovery that a body could be made attractive by rubbing is attributed to Thales (640-548 B.C). He seems to have been led to it through the Greeks' practice of spinning silk with an amber spindle; the rubbing of the spindle cause the silk to be attracted to it. The Greek world of amber is *electron*, and a body made attractive by rubbing is said to be *electrified* or *charged*. The branch of electricity is called *Electrostatics*.

### 1.2.2 Conductor and insulator

16

Thales

Gilbert

(1700) 100

---

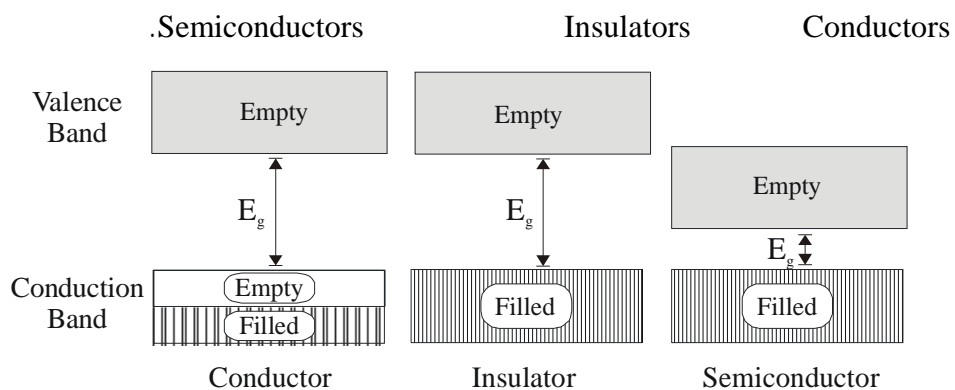
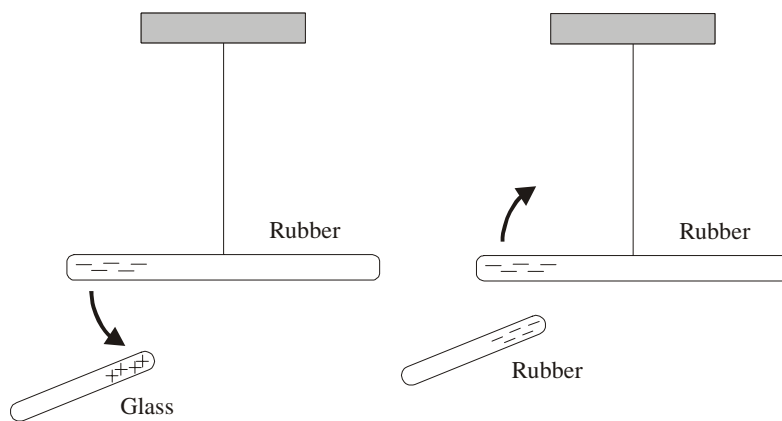

Figure 1.1





**Figure 1.2**  
*Unlike charges attract one another and like charge repel one another*

Negative

Franklin

### 1.2.4 Charge is conserved

.Normal

( )

.Conservation of electric charge

### 1.2.5 Charge and Matter

.Atom

(1)

Particle	Symbol	Charge	Mass
Proton	$p$	$1.6 \times 10^{-19} \text{C}$	$1.67 \times 10^{-27} \text{K}$
Neutron	$n$	0	$1.67 \times 10^{-27} \text{K}$
Electron	$e$	$-1.6 \times 10^{-19} \text{C}$	$1.67 \times 10^{-31} \text{K}$

Table 1.1

### 1.2.6 Charge is Quantized

Franklin's

$.1.6 \times 10^{-19} \text{c}$

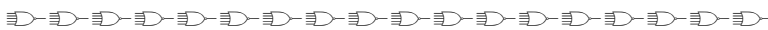

**LECTURES IN GENERAL PHYSICS**

# *Electrostatic*

*Principles and Applications*

Dr. Hazem Falah Sakeek

Al-Azhar University - Gaza

*Part Two*

## Chapter 2

# Coulomb's Law



قانون كولوم



# **Coulomb's law**

## **2.1 Coulomb's Law**

## **2.2 Calculation of the electric force**

2.2.1 Electric force between two electric charges

2.2.2 Electric force between more than two electric charges

## **2.3 Problems**

# ***Coulomb's law***



## 2.1 Coulomb's Law

In 1785, Coulomb established the fundamental law of *electric force* between two stationary, charged particles. Experiments show that an electric force has the following properties:

(1) The force is *inversely proportional* to the square of separation,  $r^2$ , between the two charged particles.

$$F \propto \frac{1}{r^2} \quad (2.1)$$

(2) The force is *proportional* to the product of charge  $q_1$  and the charge  $q_2$  on the particles.

$$F \propto q_1 q_2 \quad (2.2)$$

(3) The force is *attractive* if the charges are of opposite sign and *repulsive* if the charges have the same sign.

We can conclude that

$$F \propto \frac{q_1 q_2}{r^2}$$

$$\therefore F = K \frac{q_1 q_2}{r^2} \quad (2.3)$$

where  $K$  is the coulomb constant =  $9 \times 10^9 \text{ N.m}^2/\text{C}^2$ .

The above equation is called **Coulomb's law**, which is used to calculate the force between electric charges. In that equation  $F$  is measured in Newton (N),  $q$  is measured in unit of coulomb (C) and  $r$  in meter (m).

The constant  $K$  can be written as

$$K = \frac{1}{4\pi\epsilon_0}$$

where  $\epsilon_0$  is known as the *Permittivity constant of free space*.

$$\epsilon_0 = 8.85 \times 10^{-12} \text{ C}^2/\text{N.m}^2$$

$$K = \frac{1}{4\pi\epsilon_0} = \frac{1}{4\pi \times 8.85 \times 10^{-12}} = 9 \times 10^9 \text{ N.m}^2 / \text{C}^2$$

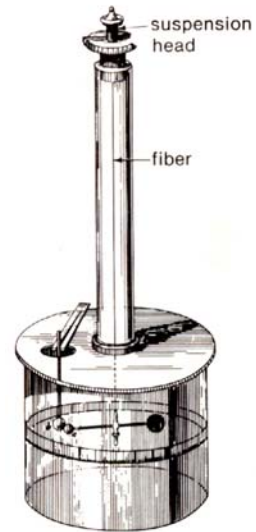

Figure 2.1

## 2.2 Calculation of the electric force

$q_1$   
-:

### 2.2.1 Electric force between two electric charges

Figure 2.2(a)  
.Repulsive force

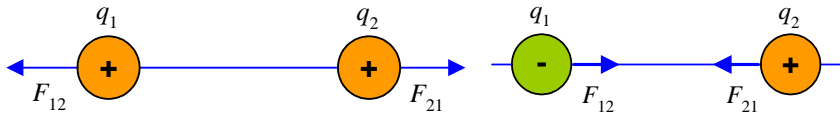

Figure 2.2(a)

Figure 2.2(b)

$q_2$        $q_1$   
·  $q_2$        $F_{12}$        $q_2$        $q_1$   
:

$$F_{12} = K \frac{q_1 q_2}{r^2} = F_{21}$$

$$\vec{F}_{12} = -\vec{F}_{21}$$

Figure 2.2(b)  
.Attractive force

$$\vec{F}_{12} = -\vec{F}_{21}$$



**Example 2.1**

Calculate the value of two equal charges if they repel one another with a force of 0.1N when situated 50cm apart in a vacuum.



**Solution**

$$F = K \frac{q_1 q_2}{r^2}$$

Since  $q_1=q_2$

$$0.1 = \frac{9 \times 10^9 \times q^2}{(0.5)^2}$$

$$q = 1.7 \times 10^{-6} \text{C} = 1.7 \mu\text{C}$$

.0.1N

**2.2.2 Electric force between more than two electric charges**

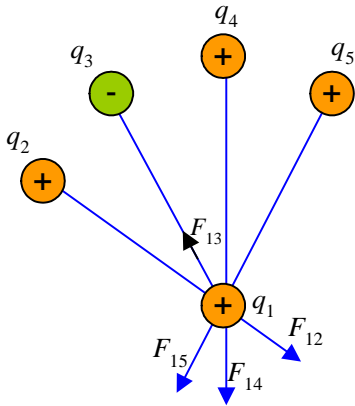

Figure 2.3

The resultant electric forces

Figure 2.3

$$\vec{F}_1 = \vec{F}_{12} + \vec{F}_{13} + \vec{F}_{14} + \vec{F}_{15} \quad (2.4)$$

$$\therefore \quad \vec{F}_1$$

$q_1$

$q_1$

$q_1 \& q_2$

(2)

$q_1$

$F_{12}$

$q_2$

$$q_1 & q_3 \quad \cdot \quad q_2$$

$$F_{14} \quad F_{13}$$

$$q_2 \text{ \& } q_3 \text{ \& } q_4 \quad (3)$$

$$\cdot q_1 \quad (4)$$

$$F_{12} = K \frac{q_1 q_2}{r^2}$$

$$F_{13} = K \frac{q_1 q_3}{r^2}$$

$$F_{14} = K \frac{q_1 q_4}{r^2}$$

$$F_1 \quad (5)$$

$$F_{1x} = F_{12x} + F_{13x} + F_{14x}$$

$$F_{1y} = F_{12y} + F_{13y} + F_{14y}$$

$$F_1 = \sqrt{(F_x)^2 + (F_y)^2} \quad (2.5)$$

$$\theta = \tan^{-1} \frac{F_y}{F_x} \quad (2.6)$$



**Example 2.2**

In figure 2.4, two equal positive charges  $q=2 \times 10^{-6} \text{C}$  interact with a third charge  $Q=4 \times 10^{-6} \text{C}$ . Find the magnitude and direction of the resultant force on  $Q$ .

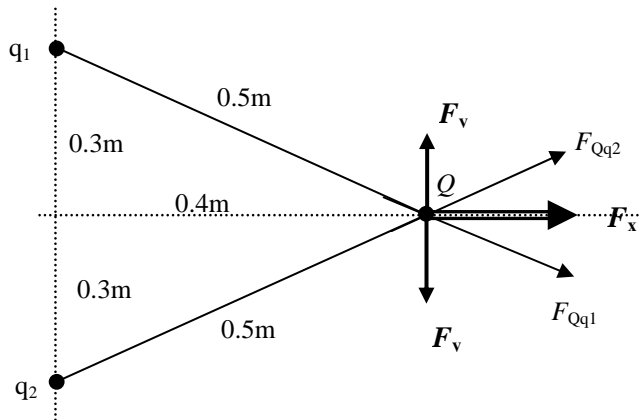
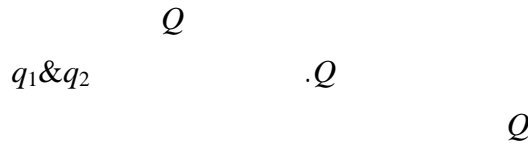

Figure 2.4



**Solution**



$$F_{Qq1} = K \frac{qQ}{r^2} = 9 \times 10^9 \frac{(4 \times 10^{-6})(2 \times 10^{-6})}{(0.5)^2} = 0.29 \text{ N} = F_{Qq2}$$

:

$$F_x = F \cos \theta = 0.29 \left( \frac{0.4}{0.5} \right) = 0.23 \text{ N}$$

$$F_y = -F \sin \theta = -0.29 \left( \frac{0.3}{0.5} \right) = -0.17 \text{ N}$$

$$F_{Qq2} \quad Q \quad q_2$$

y

$$\sum F_x = 2 \times 0.23 = 0.46 \text{ N}$$

$$\sum F_y = 0$$

x

0.46N



### Example 2.3

In figure 2.5 what is the resultant force on the charge in the lower left corner of the square? Assume that  $q=1 \times 10^{-7} \text{ C}$  and  $a = 5 \text{ cm}$

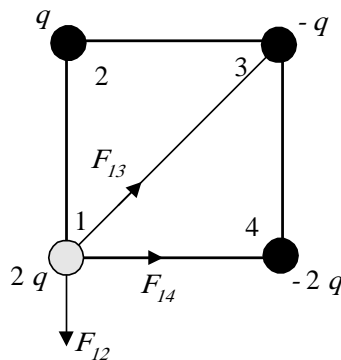

Figure 2.5



### Solution

For simplicity we number the charges as shown in figure 2.5, then we determine the direction of the electric forces acted on the charge in the lower left corner of the square  $q_1$

$$\vec{F}_1 = \vec{F}_{12} + \vec{F}_{13} + \vec{F}_{14}$$

$$F_{12} = K \frac{2qq}{a^2}$$

$$F_{13} = K \frac{2qq}{2a^2}$$

$$F_{14} = K \frac{2q2q}{a^2}$$



$$F_{12} = 0.072 \text{ N},$$

$$F_{13} = 0.036 \text{ N},$$

$$F_{14} = 0.144 \text{ N}$$

x,y

$F_{13}$

$$F_{13x} = F_{13} \sin 45 = 0.025 \text{ N} \quad \&$$

$$F_{13y} = F_{13} \cos 45 = 0.025 \text{ N}$$

$$F_x = F_{13x} + F_{14} = 0.025 + 0.144 = 0.169 \text{ N}$$

$$F_y = F_{13y} - F_{12} = 0.025 - 0.072 = -0.047 \text{ N}$$

y

The resultant force equals

$$F_1 = \sqrt{(F_x)^2 + (F_y)^2} = 0.175 \text{ N}$$

The direction with respect to the x-axis equals

$$\theta = \tan^{-1} \frac{F_y}{F_x} = -15.5^\circ$$

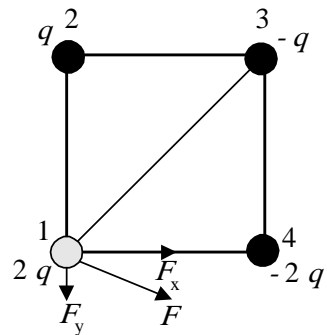



### Example 2.4

A charge  $Q$  is fixed at each of two opposite corners of a square as shown in figure 2.6. A charge  $q$  is placed at each of the other two corners. (a) If the resultant electrical force on  $Q$  is Zero, how are  $Q$  and  $q$  related.

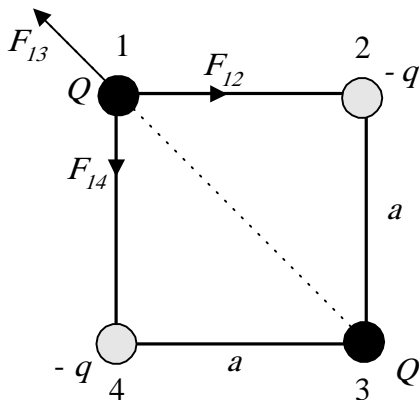

Figure 2.6



### Solution

$$\begin{aligned}
 & Q \\
 (1) \quad & Q && Q \\
 & (3) \quad (1) \quad Q && (4) \quad (2) \\
 &&&&&& \cdot(1)
 \end{aligned}$$

$$F_{13} \qquad \qquad \qquad \cdot(2.6)$$

$$F_x = 0 \Rightarrow F_{12} - F_{13x} = 0$$

then

$$F_{12} = F_{13} \cos 45$$

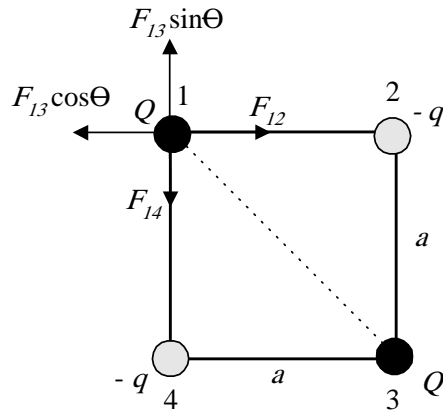

$$K \frac{Qq}{a^2} = K \frac{QQ}{2a^2} \frac{1}{\sqrt{2}} \Rightarrow q = \frac{Q}{2\sqrt{2}}$$

$$F_y = 0 \Rightarrow F_{13y} - F_{14} = 0$$

$$F_{13} \sin 45 = F_{14}$$

$$K \frac{QQ}{2a^2} \frac{1}{\sqrt{2}} = K \frac{Qq}{a^2} \Rightarrow q = \frac{Q}{2\sqrt{2}}$$

$$Q = 2\sqrt{2}q$$

$$Q = -2\sqrt{2}q$$



**Example 2.5**

Two fixed charges,  $1\mu\text{C}$  and  $-3\mu\text{C}$  are separated by  $10\text{cm}$  as shown in figure 2.7 (a) where may a third charge be located so that no force acts on it? (b) is the equilibrium stable or unstable for the third charge?

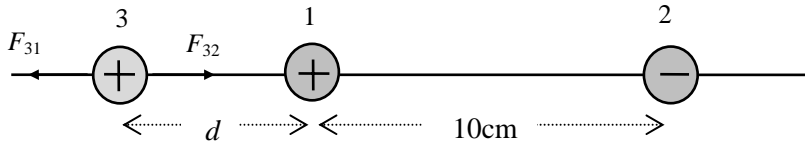

Figure 2.7



**Solution**

) .equilibrium

.(

$q_3$

$$F_{31} = F_{32}$$

$$k \frac{q_3 q_1}{r_{31}^2} = k \frac{q_3 q_2}{r_{32}^2}$$

$$\frac{1 \times 10^{-6}}{d^2} = \frac{3 \times 10^{-6}}{(d + 10)^2}$$

$d$

(b) This equilibrium is unstable!! Why!!



**Example 2.6**

Two charges are located on the positive x-axis of a coordinate system, as shown in figure 2.8. Charge  $q_1=2\text{nC}$  is 2cm from the origin, and charge  $q_2=-3\text{nC}$  is 4cm from the origin. What is the total force exerted by these two charges on a charge  $q_3=5\text{nC}$  located at the origin?

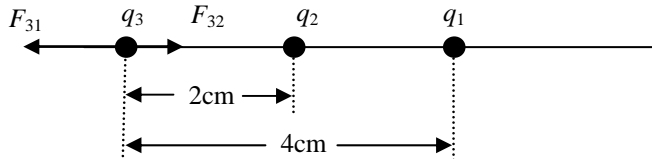

Figure 2.8



**Solution**

The total force on  $q_3$  is the vector sum of the forces due to  $q_1$  and  $q_2$  individually.

$$F_{31} = \frac{(9 \times 10^9)(2 \times 10^{-9})(5 \times 10^{-9})}{(0.02)^2} = 2.25 \times 10^{-4} \text{ N}$$

$$F_{32} = \frac{(9 \times 10^9)(3 \times 10^{-9})(5 \times 10^{-9})}{(0.04)^2} = 0.84 \times 10^{-4} \text{ N}$$

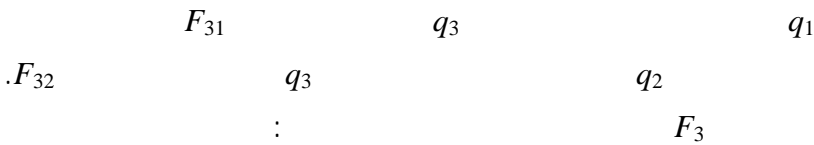

$$F_3 = F_{31} + F_{32}$$

$$\therefore F_3 = 0.84 \times 10^{-4} - 2.25 \times 10^{-4} = -1.41 \times 10^{-4} \text{ N}$$

The total force is directed to the left, with magnitude  $1.41 \times 10^{-4} \text{ N}$ .



## 2.3 Problems

---

2.1) Two protons in a molecule are separated by a distance of  $3.8 \times 10^{-10}$  m. Find the electrostatic force exerted by one proton on the other.

2.2) A  $6.7 \mu\text{C}$  charge is located 5m from a  $-8.4 \mu\text{C}$  charge. Find the electrostatic force exerted by one on the other.

2.3) Two fixed charges,  $+1.0 \times 10^{-6}\text{C}$  and  $-3.0 \times 10^{-6}\text{C}$ , are 10cm apart. (a) Where may a third charge be located so that no force acts on it? (b) Is the equilibrium of this third charge stable or unstable?

2.4) Each of two small spheres is charged positively, the combined charge being  $5.0 \times 10^{-5}\text{C}$ . If each sphere is repelled from the other by a force of 1.0N when the spheres are 2.0m apart, how is the total charge distributed between the spheres?

2.5) A certain charge  $Q$  is to be divided into two parts,  $q$  and  $Q-q$ . What is the relationship of  $Q$  to  $q$  if the two parts, placed a given distance apart, are to have a maximum Coulomb repulsion?

2.6) A  $1.3 \mu\text{C}$  charge is located on the  $x$ -axis at  $x=-0.5\text{m}$ ,  $3.2 \mu\text{C}$  charge is located on the  $x$ -axis at  $x=1.5\text{m}$ , and  $2.5 \mu\text{C}$  charge is located at the

origin. Find the net force on the  $2.5 \mu\text{C}$  charge.

2.7) A point charge  $q_1 = -4.3 \mu\text{C}$  is located on the  $y$ -axis at  $y=0.18\text{m}$ , a charge  $q_2 = 1.6 \mu\text{C}$  is located at the origin, and a charge  $q_3 = 3.7 \mu\text{C}$  is located on the  $x$ -axis at  $x = -0.18\text{m}$ . Find the resultant force on the charge  $q_1$ .

2.8) Three point charges of  $2 \mu\text{C}$ ,  $7 \mu\text{C}$ , and  $-4 \mu\text{C}$  are located at the corners of an equilateral triangle as shown in the figure 2.9. Calculate the net electric force on  $7 \mu\text{C}$  charge.

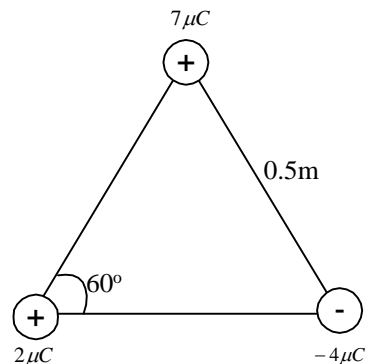

Figure 2.9

2.9) Two free point charges  $+q$  and  $+4q$  are a distance 1cm apart. A third charge is so placed that the entire system is in equilibrium. Find the location, magnitude and sign of the third charge. Is the equilibrium stable?

2.10) Four point charges are situated at the corners of a square of sides  $a$  as shown in the figure 2.10. Find the resultant force on the positive charge  $+q$ .

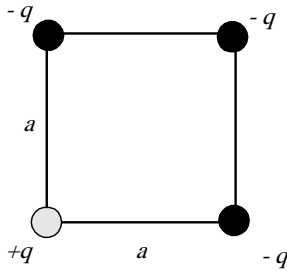

Figure 2.10

2.13) Two similar conducting balls of mass  $m$  are hung from silk threads of length  $l$  and carry similar charges  $q$  as shown in the figure 2.11. Assume that  $\theta$  is so small that  $\tan\theta$  can be replaced by  $\sin\theta$ . Show that

$$x = \left( \frac{q^2 l}{2\pi\epsilon_0 mg} \right)^{1/3}$$

where  $x$  is the separation between the balls (b) If  $l=120\text{cm}$ ,  $m=10\text{g}$  and  $x=5\text{cm}$ , what is  $q$ ?

2.11) Three point charges lie along the  $y$ -axis. A charge  $q_1=-9\mu\text{C}$  is at  $y=6.0\text{m}$ , and a charge  $q_2=-8\mu\text{C}$  is at  $y=-4.0\text{m}$ . Where must a third positive charge,  $q_3$ , be placed such that the resultant force on it is zero?

2.12) A charge  $q_1$  of  $+3.4\mu\text{C}$  is located at  $x=+2\text{m}$ ,  $y=+2\text{m}$  and a second charge  $q_2=+2.7\mu\text{C}$  is located at  $x=-4\text{m}$ ,  $y=-4\text{m}$ . Where must a third charge ( $q_3>0$ ) be placed such that the resultant force on  $q_3$  will be zero?

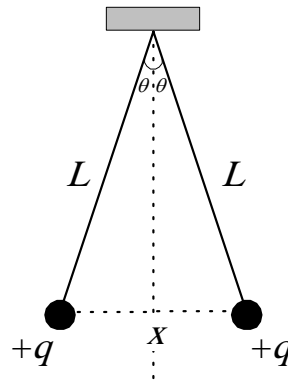

Figure 2.11

**LECTURES IN GENERAL PHYSICS**

# *Electrostatic*

*Principles and Applications*

Dr. Hazem Falah Sakeek

Al-Azhar University - Gaza

*Part Two*



## Chapter 3

# *Electric Field*



# Electric field

## 3.1 The Electric Field

## 3.2 Definition of the electric field

## 3.3 The direction of $\vec{E}$

## 3.4 Calculating $\vec{E}$ due to a charged particle

## 3.5 To find $\vec{E}$ for a group of point charge

## 3.6 Electric field lines

## 3.7 Motion of charge particles in a uniform electric field

## 3.8 Solution of some selected problems

## 3.9 The electric dipole in electric field

## 3.10 Problems

# ***Electric field***

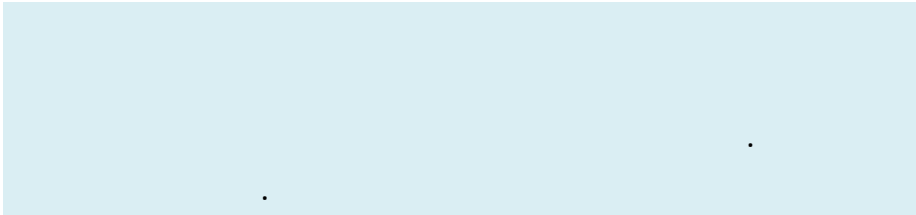

### 3.1 The Electric Field

The gravitational field  $g$  at a point in space was defined to be equal to the gravitational force  $F$  acting on a test mass  $m_o$  divided by the test mass

$$\vec{g} = \frac{\vec{F}}{m_o} \quad (3.1)$$

In the same manner, an **electric field** at a point in space can be defined in term of electric force acting on a test charge  $q_o$  placed at that point.

### 3.2 Definition of the electric field

The electric field vector  $\vec{E}$  at a point in space is defined as the electric force  $\vec{F}$  acting on a positive test charge placed at that point divided by the magnitude of the test charge  $q_o$

$$\vec{E} = \frac{\vec{F}}{q_o} \quad (3.2)$$

The electric field has a unit of N/C

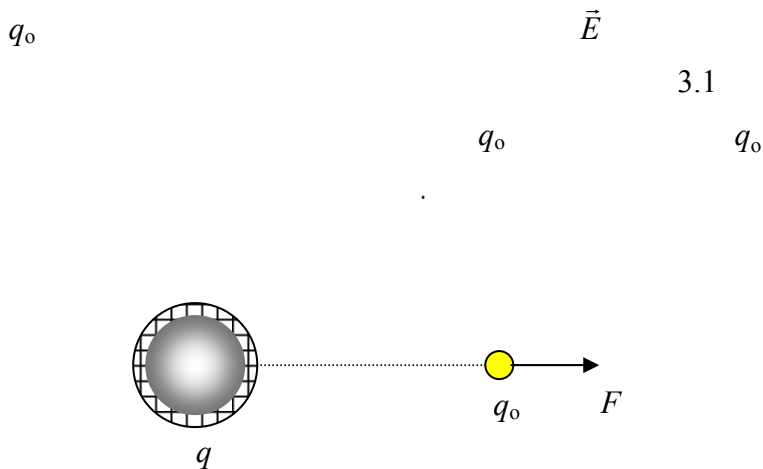

**Figure 3.1**

### 3.3 The direction of $\vec{E}$

If  $Q$  is +ve the electric field at point  $p$  in space is radially outward from  $Q$  as shown in figure 3.2(a).

If  $Q$  is -ve the electric field at point  $p$  in space is radially inward toward  $Q$  as shown in figure 3.2(b).

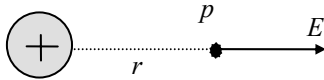

Figure 3.2 (a)

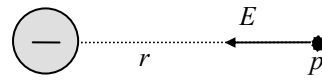

Figure 3.2 (b)

3.2(a)

.3.2(b)

### 3.4 Calculating $\vec{E}$ due to a charged particle

Consider Fig. 3.2(a) above, the magnitude of force acting on  $q_o$  is given by Coulomb's law

$$F = \frac{1}{4\pi\epsilon_o} \frac{Qq_o}{r^2}$$

$$E = \frac{F}{q_o}$$

$$E = \frac{1}{4\pi\epsilon_o} \frac{Q}{r^2} \quad (3.3)$$

### 3.5 To find $E$ for a group of point charge

To find the magnitude and direction of the electric field due to several charged particles as shown in figure 3.3 use the following steps

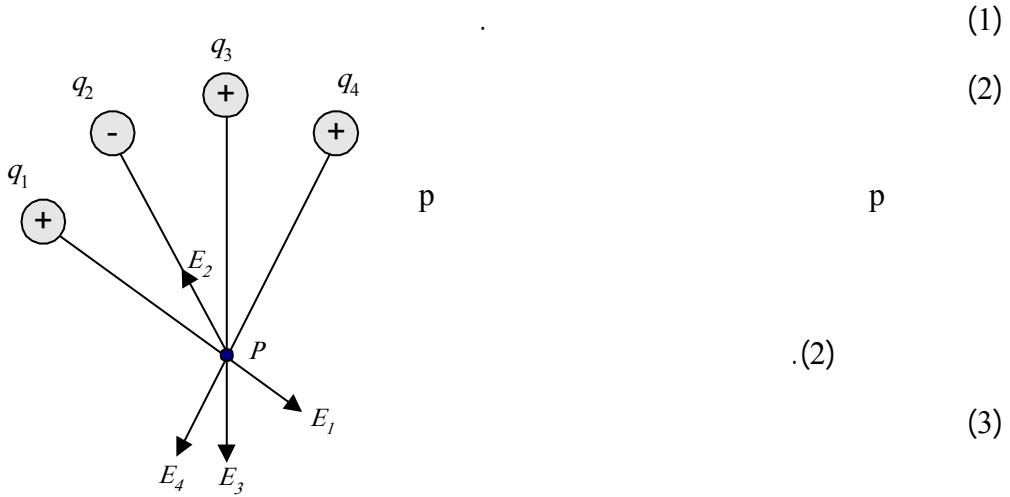

Figure 3.3

$$\vec{E}_p = \vec{E}_1 + \vec{E}_2 + \vec{E}_3 + \vec{E}_4 + \dots \quad (3.4)$$

(4)

y x

.y x (5)

$$E_x = E_{1x} + E_{2x} + E_{3x} + E_{4x}$$

$$E_y = E_{1y} + E_{2y} + E_{3y} + E_{4y}$$

$$E = \sqrt{E_x^2 + E_y^2} \quad p \quad (6)$$

$$\theta = \tan^{-1} \frac{E_y}{E_x} \quad (7)$$



**Example 3.1**

Find the electric field at point  $p$  in figure 3.4 due to the charges shown.

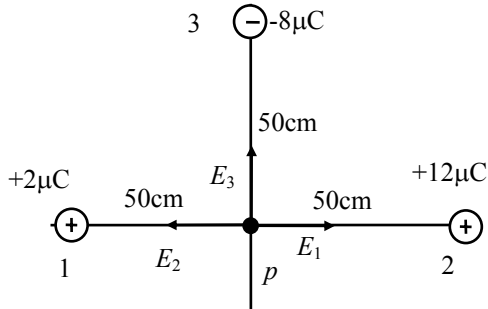

Figure 3.4



**Solution**

$$\vec{E}_p = \vec{E}_1 + \vec{E}_2 + \vec{E}_3$$

$$E_x = E_1 - E_2 = -36 \times 10^4 \text{ N/C}$$

$$E_y = E_3 = 28.8 \times 10^4 \text{ N/C}$$

$$E_p = \sqrt{(36 \times 10^4)^2 + (28.8 \times 10^4)^2} = 46.1 \text{ N/C}$$

$$\theta = 141^\circ$$

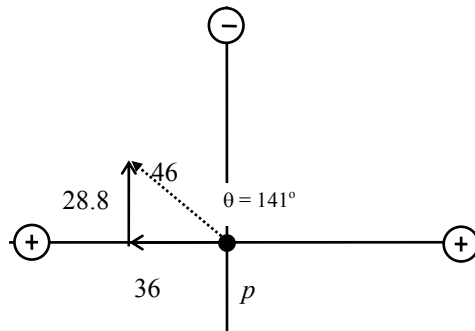

Figure 3.5 Shows the resultant electric field



**Example 3.2**

Find the electric field due to electric dipole along x-axis at point  $p$ , which is a distance  $r$  from the origin, then assume  $r \gg a$

The electric dipole is positive charge and negative charge of equal magnitude placed a distance  $2a$  apart as shown in figure 3.6

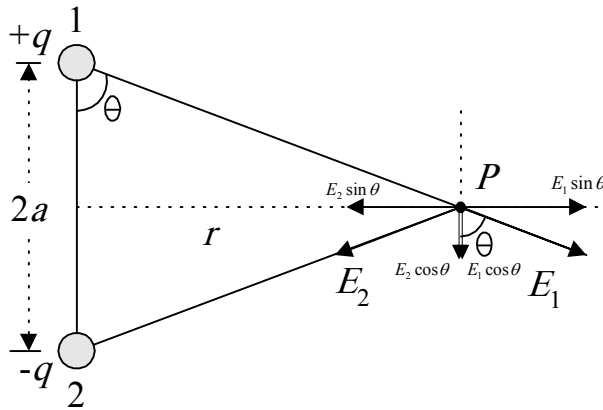

Figure 3.6



**Solution**

$$\vec{E}_p = \vec{E}_1 + \vec{E}_2$$

$$E_1 = \frac{1}{4\pi\epsilon_0} \frac{q_1}{a^2 + r^2} = E_2$$

$$E_x = E_1 \sin\theta - E_2 \sin\theta$$



$$E_y = E_1 \cos\theta + E_2 \cos\theta = 2E_1 \cos\theta$$

$$E_p = 2E_1 \cos\theta$$

$$E_p = \frac{1}{4\pi\epsilon_0} \frac{q}{a^2 + r^2} \cos\theta$$

from the Figure

$$\cos\theta = \frac{a}{\sqrt{a^2 + r^2}}$$

$$E_p = \frac{1}{4\pi\epsilon_0} \frac{q}{a^2 + r^2} \frac{a}{\sqrt{a^2 + r^2}}$$

$$E_p = \frac{2aq}{4\pi\epsilon_0 (r^2 + a^2)^{3/2}} \quad (3.5)$$

The direction of the electric field in the -ve y-axis.

The quantity  $2aq$  is called the **electric dipole momentum** ( $P$ ) and has a direction from the -ve charge to the +ve charge

(b) when  $r \gg a$

$$\therefore E = \frac{2aq}{4\pi\epsilon_0 r^3} \quad (3.6)$$

electric dipole

electric dipole momentum

electric dipole

### 3.6 Electric field lines

The electric lines are a convenient way to visualize the electric field patterns. The relation between the electric field lines and the electric field vector is this:

- (1) The tangent to a line of force at any point gives the direction of  $\vec{E}$  at that point.
- (2) The lines of force are drawn so that the number of lines per unit cross-sectional area is proportional to the magnitude of  $\vec{E}$ .

#### Some examples of electric line of force

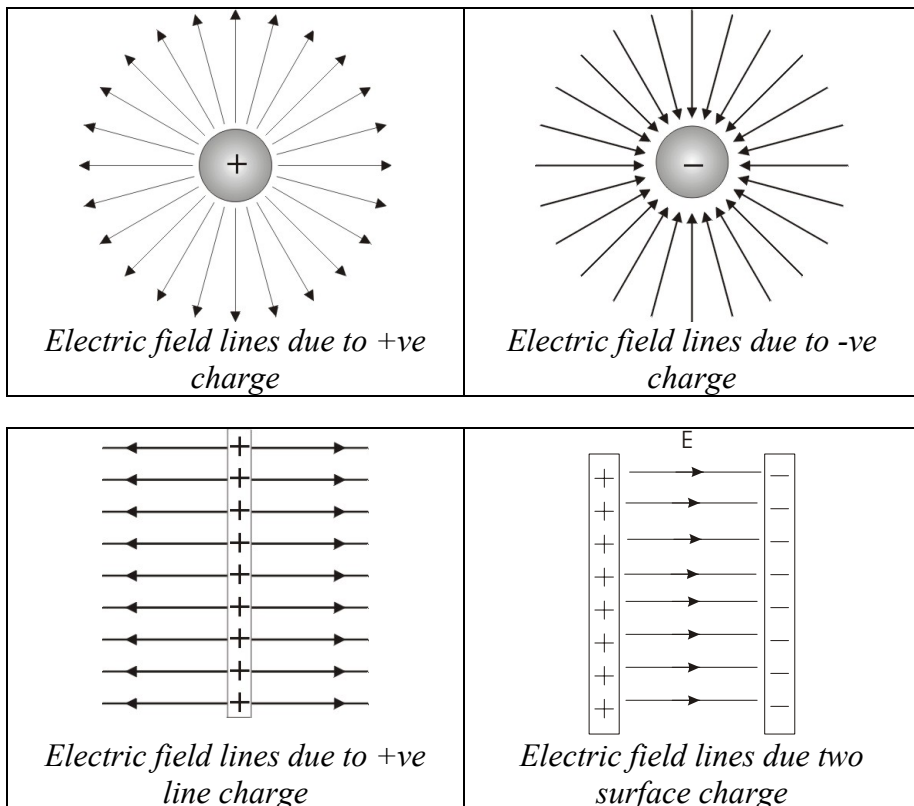

*Figure 3.7 shows some examples of electric line of force*

*Notice that the rule of drawing the line of force:-*

- (1) The lines must begin on positive charges and terminates on negative charges.
- (2) The number of lines drawn is proportional to the magnitude of the charge.
- (3) No two electric field lines can cross.

### **3.7 Motion of charge particles in a uniform electric field**

If we are given a field  $\vec{E}$ , what forces will act on a charge placed in it?

We start with special case of a point charge in uniform electric field  $\vec{E}$ . The electric field will exert a force on a charged particle is given by

$$F = qE$$

The force will produce acceleration

$$a = F/m$$

where  $m$  is the mass of the particle. Then we can write

$$F = qE = ma$$

The acceleration of the particle is therefore given by

$$a = qE/m \quad (3.7)$$

**If the charge is positive, the acceleration will be in the direction of the electric field. If the charge is negative, the acceleration will be in the direction opposite the electric field.**

One of the practical applications of this subject is a device called the (*Oscilloscope*) See appendix A (*Cathode Ray Oscilloscope*) for further information.

### **3.8 Solution of some selected problems**

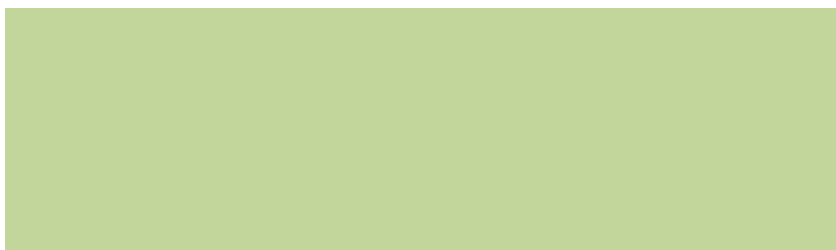

### 3.8 Solution of some selected problems



#### Example 3.3

A positive point charge  $q$  of mass  $m$  is released from rest in a uniform electric field  $\vec{E}$  directed along the  $x$ -axis as shown in figure 3.8, describe its motion.

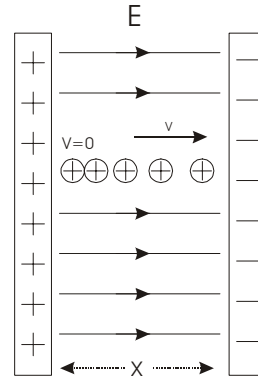

Figure 3.8



#### Solution

The acceleration is given by

$$a = qE/m$$

Since the motion of the particle in one dimension, then we can apply the equations of kinematics in one dimension

$$x-x_0 = v_0t + \frac{1}{2} at^2 \quad v = v_0 + at \quad v^2 = v_0^2 + 2a(x-x_0)$$

Taking  $x_0 = 0$  and  $v_0 = 0$

$$x = \frac{1}{2} at^2 = (qE/2m) t^2$$

$$v = at = (qE/m) t$$

$$v^2 = 2ax = (2qE/m)x \quad (3.7)$$



**Example 3.4**

In the above example suppose that a negative charged particle is projected horizontally into the uniform field with an initial velocity  $v_0$  as shown in figure 3.9.

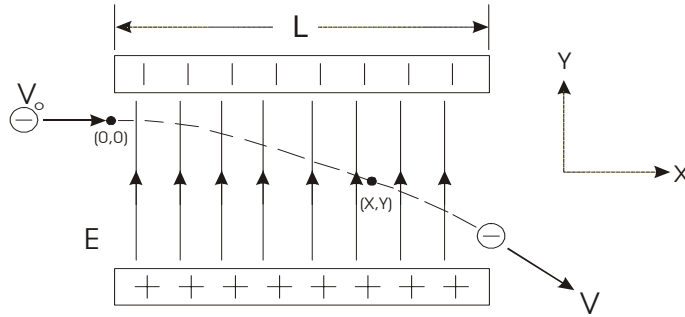

**Figure 3.9**



**Solution**

Since the direction of electric field  $\vec{E}$  in the y direction, and the charge is negative, then the acceleration of charge is in the direction of -y.

$$a = -qE/m$$

The motion of the charge is in two dimension with constant acceleration, with  $v_{x0} = v_0$  &  $v_{y0} = 0$

The components of velocity after time  $t$  are given by

$$v_x = v_0 = \text{constant}$$

$$v_y = at = - (qE/m) t$$

The coordinate of the charge after time  $t$  are given by

$$x = v_0 t$$

$$y = \frac{1}{2} at^2 = - \frac{1}{2} (qE/m) t^2$$

Eliminating  $t$  we get

$$y = \frac{qE}{2mv_0^2} x^2 \tag{3.8}$$

we see that  $y$  is proportional to  $x^2$ . Hence, the trajectory is parabola.



**Example 3.5**

Find the electric field due to electric dipole shown in figure 3.10 along x-axis at point  $p$  which is a distance  $r$  from the origin. then assume  $r \gg a$



**Solution**

$$\vec{E}_p = \vec{E}_1 + \vec{E}_2$$

$$E_1 = K \frac{q}{(x+a)^2}$$

$$E_2 = K \frac{q}{(x-a)^2}$$

$$E_p = K \frac{q}{(x-a)^2} - \frac{q}{(x+a)^2}$$

$$E_p = Kq \frac{4ax}{(x^2 - a^2)^2}$$

When  $x \gg a$  then

$$\therefore E = \frac{2aq}{4\pi\epsilon_0 x^3} \quad (3.9)$$

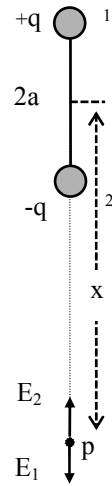

**Figure 3.10**

$2a$

$x$



**Example 3.6**

What is the electric field in the lower left corner of the square as shown in figure 3.11? Assume that  $q = 1 \times 10^{-7} \text{C}$  and  $a = 5 \text{cm}$ .



**Solution**

First we assign number to the charges (1, 2, 3, 4) and then determine the direction of the electric field at the point  $p$  due to the charges.

$$E_1 = \frac{1}{4\pi\epsilon_0} \frac{q}{a^2}$$

$$E_2 = \frac{1}{4\pi\epsilon_0} \frac{q}{2a^2}$$

$$E_3 = \frac{1}{4\pi\epsilon_0} \frac{2q}{a^2}$$

Evaluate the value of  $E_1$ ,  $E_2$ , &  $E_3$

$$E_1 = 3.6 \times 10^5 \text{ N/C},$$

$$E_2 = 1.8 \times 10^5 \text{ N/C},$$

$$E_3 = 7.2 \times 10^5 \text{ N/C}$$

Since the resultant electric field is the vector additions of all the fields *i.e.*

$$\vec{E}_p = \vec{E}_1 + \vec{E}_2 + \vec{E}_3$$

We find the vector  $E_2$  need analysis to two components

$$E_{2x} = E_2 \cos 45$$

$$E_{2y} = E_2 \sin 45$$

$$E_x = E_3 - E_2 \cos 45 = 7.2 \times 10^5 - 1.8 \times 10^5 \cos 45 = 6 \times 10^5 \text{ N/C}$$

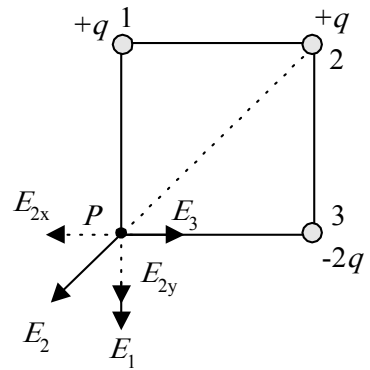

**Figure 3.11**



$$E_y = -E_1 - E_2 \sin 45 = -3.6 \times 10^5 - 1.8 \times 10^5 \sin 45 = -4.8 \times 10^5 \text{ N/C}$$

$$E = \sqrt{E_x^2 + E_y^2} = 7.7 \times 10^5 \text{ N/C}$$

$$\theta = \tan^{-1} \frac{E_y}{E_x} = -38.6^\circ$$



### Example 3.7

In figure 3.12 shown, locate the point at which the electric field is zero?  
Assume  $a = 50\text{cm}$



### Solution

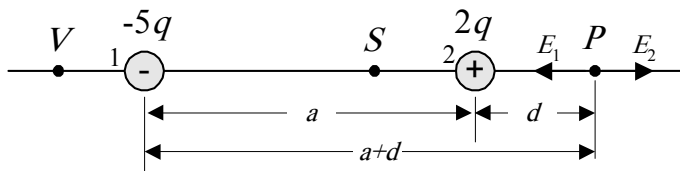

Figure 3.12

To locate the points at which the electric field is zero ( $E=0$ ), we shall try all the possibilities, assume the points  $S$ ,  $V$ ,  $P$  and find the direction of  $E_1$  and  $E_2$  at each point due to the charges  $q_1$  and  $q_2$ .

The resultant electric field is zero only when  $E_1$  and  $E_2$  are equal in magnitude and opposite in direction.

At the point  $S$   $E_1$  in the same direction of  $E_2$  therefore  $E$  cannot be zero in between the two charges.

## *Electric Field*

---

At the point  $V$  the direction of  $E_1$  is opposite to the direction of  $E_2$ , but the magnitude could not be equal (can you find the reason?)

At the point  $P$  the direction of  $E_1$  and  $E_2$  are in opposite to each other and the magnitude can be equal

$$E_1 = E_2$$

$$\frac{1}{4\pi\epsilon_0} \frac{2q}{(0.5 + d)^2} = \frac{1}{4\pi\epsilon_0} \frac{5q}{(d)^2}$$

$$d = 30\text{cm}$$



**Example 3.8**

A charged cord ball of mass 1g is suspended on a light string in the presence of a uniform electric field as in figure 3.13. When  $E=(3i+5j) \times 10^5 \text{N/C}$ , the ball is in equilibrium at  $\theta=37^\circ$ . Find (a) the charge on the ball and (b) the tension in the string.

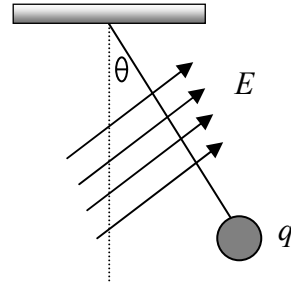
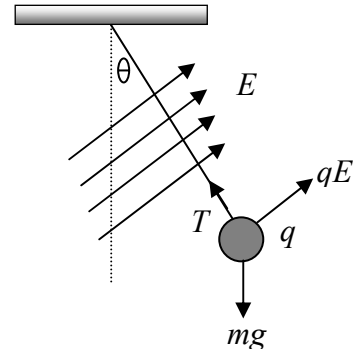

Figure 3.13



**Solution**



$$\sum F = ma$$

$$E_x = 3 \times 10^5 \text{N/C} \quad E_y = 5j \times 10^5 \text{N/C}$$

$$\sum F = T + qE + F_g = 0$$

$$\sum F_x = qE_x - T \sin 37 = 0 \tag{1}$$

$$\sum F_y = qE_y + T \cos 37 - mg = 0 \tag{2}$$

Substitute T from equation (1) into equation (2)

$$q = \frac{mg}{\left(E_y + \frac{E_x}{\tan 37}\right)} = \frac{(1 \times 10^{-3})(9.8)}{\left(5 + \frac{3}{\tan 37}\right) \times 10^5} = 1.09 \times 10^{-8} \text{ C}$$

To find the tension we substitute for q in equation (1)

$$T = \frac{qE_x}{\sin 37} = 5.44 \times 10^{-3} \text{ N}$$

### 3.9 The electric dipole in electric field

If an electric dipole placed in an external electric field  $E$  as shown in figure 3.14, then a torque will act to align it with the direction of the field.

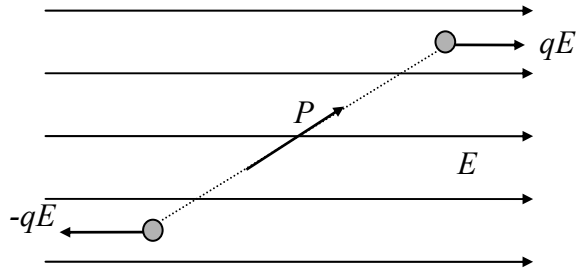

*Figure 3.14*

$$\vec{\tau} = \vec{P} \times \vec{E} \quad (3.10)$$

$$\tau = P E \sin \theta \quad (3.11)$$

where  $P$  is the electric dipole momentum,  $\theta$  the angle between  $P$  and  $E$

equilibrium  
( $\theta = 0, \pi$ )

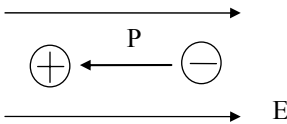

*Figure 3.15 (ii)*

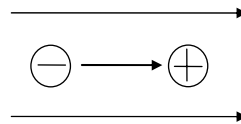

*Figure 3.15 (i)*

	dipole	θ = 0 =	3.15(i)
θ = 0 =			stable equilibrium
	dipole	θ = π =	3.15(ii)
dipole			unstable equilibrium



### 3.10 Problems

- 3.1) The electric force on a point charge of  $4.0\mu\text{C}$  at some point is  $6.9\times 10^{-4}\text{N}$  in the positive  $x$  direction. What is the value of the electric field at that point?
- 3.2) What are the magnitude and direction of the electric field that will balance the weight of (a) an electron and (b) a proton? (Use the data in Table 1.)
- 3.3) A point charge of  $-5.2\mu\text{C}$  is located at the origin. Find the electric field (a) on the  $x$ -axis at  $x=3\text{m}$ , (b) on the  $y$ -axis at  $y=-4\text{m}$ , (c) at the point with coordinates  $x=2\text{m}$ ,  $y=2\text{m}$ .
- 3.4) What is the magnitude of a point charge chosen so that the electric field 50cm away has the magnitude  $2.0\text{N/C}$ ?
- 3.5) Two point charges of magnitude  $+2.0\times 10^{-7}\text{C}$  and  $+8.5\times 10^{-11}\text{C}$  are 12cm apart. (a) What electric field does each produce at the site of the other? (b) What force acts on each?
- 3.6) An electron and a proton are each placed at rest in an external electric field of  $520\text{N/C}$ . Calculate the speed of each particle after 48nanoseconds.
- 3.7) The electrons in a particle beam each have a kinetic energy of  $1.6\times 10^{-17}\text{J}$ . What are the magnitude and direction of the electric field that will stop these electrons in a distance of 10cm?
- 3.8) A particle having a charge of  $-2.0\times 10^{-9}\text{C}$  is acted on by a downward electric force of  $3.0\times 10^{-6}\text{N}$  in a uniform electric field. (a) What is the strength of the electric field? (b) What is the magnitude and direction of the electric force exerted on a proton placed in this field? (c) What is the gravitational force on the proton? (d) What is the ratio of the electric to the gravitational forces in this case?
- 3.9) Find the total electric field along the line of the two charges shown in figure 3.16 at the point midway between them.
- 3.10) What is the magnitude and direction of an electric field that will balance the weight of (a) an electron and (b) a proton?

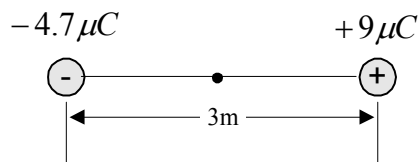
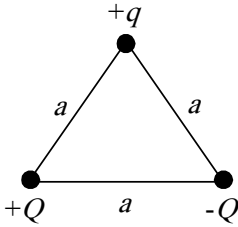

Figure 3.16

3.11) Three charges are arranged in an equilateral triangle as shown in figure 3.17. What is the direction of the force on  $+q$ ?



*Figure 3.17*

3.12) In figure 3.18 locate the point at which the electric field is zero and also the point at which the electric potential is zero. Take  $q=1\mu\text{C}$  and  $a=50\text{cm}$ .

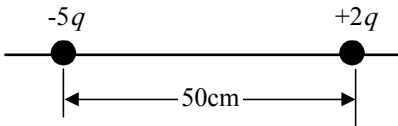

*Figure 3.18*

3.13) What is  $E$  in magnitude and direction at the center of the square shown in figure 3.19? Assume that  $q=1\mu\text{C}$  and  $a=5\text{cm}$ .

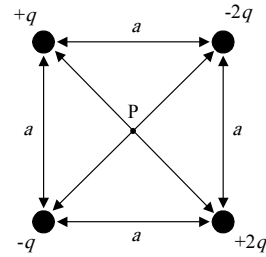

*Figure 3.19*

3.14) Two point charges are a distance  $d$  apart (Figure 3.20). Plot  $E(x)$ , assuming  $x=0$  at the left-hand charge. Consider both positive and negative values of  $x$ . Plot  $E$  as positive if  $E$  points to the right and negative if  $E$  points to the left. Assume  $q_1=+1.0\times 10^{-6}\text{C}$ ,  $q_2=+3.0\times 10^{-6}\text{C}$ , and  $d=10\text{cm}$ .

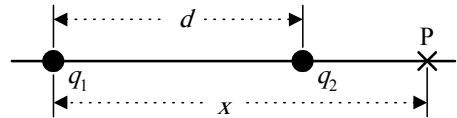

*Figure 3.20*

3.15) Calculate  $E$  (direction and magnitude) at point P in Figure 3.21.

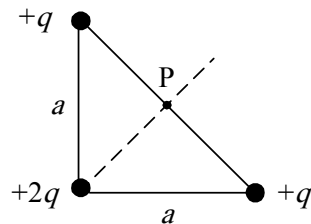

*Figure 3.21*

3.16) Charges  $+q$  and  $-2q$  are fixed a distance  $d$  apart as shown in figure 3.22. Find the electric field at points A, B, and C.

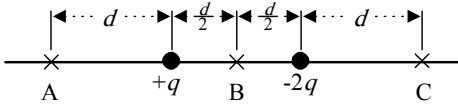

Figure 3.22

3.17) A uniform electric field exists in a region between two oppositely charged plates. An electron is

released from rest at the surface of the negatively charged plate and strikes the surface of the opposite plate, 2.0cm away, in a time  $1.5 \times 10^{-8}$ s. (a) What is the speed of the electron as it strikes the second plate? (b) What is the magnitude of the electric field  $E$ ?

**LECTURES IN GENERAL PHYSICS**

# *Electrostatic*

*Principles and Applications*

Dr. Hazem Falah Sakeek

Al-Azhar University - Gaza

*Part Two*



# Chapter 4

## *Electric Flux*

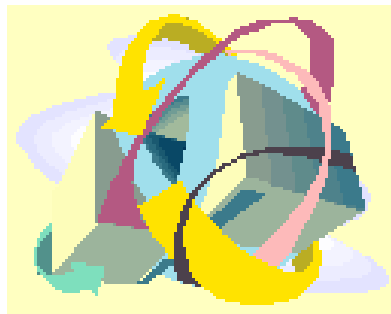

# Electric Flux

**4.1 The Electric Flux due to an Electric Field**

**4.2 The Electric Flux due to a point charge**

**4.3 Gaussian surface**

**4.4 Gauss's Law**

**4.5 Gauss's law and Coulomb's law**

**4.6 Conductors in electrostatic equilibrium**

**4.7 Applications of Gauss's law**

**4.8 Solution of some selected problems**

**4.9 Problems**

# Electric Flux

## التدفق الكهربائي



## 4.1 The Electric Flux due to an Electric Field

We have already shown how electric field can be described by lines of force. A line of force is an imaginary line drawn in such a way that its direction at any point is the same as the direction of the field at that point. Field lines never intersect, since only one line can pass through a single point.

**The Electric flux ( $\Phi$ )** is a measure of the number of electric field lines penetrating some surface of area  $A$ .

### Case one:

*The electric flux for a plan surface perpendicular to a uniform electric field (figure 4.1)*

To calculate the electric flux we recall that the number of lines per unit area is proportional to the magnitude of the electric field. Therefore, the number of lines penetrating the surface of area  $A$  is proportional to the product  $EA$ . The product of the electric field  $E$  and the surface area  $A$  perpendicular to the field is called the electric flux  $\Phi$ .

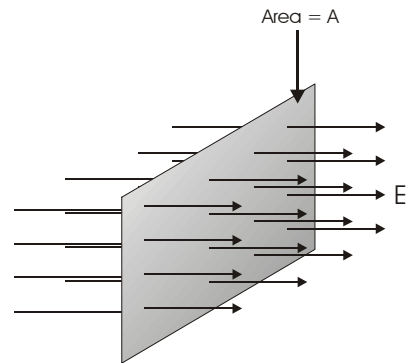

*Figure 4.1*

$$\Phi = \vec{E} \cdot \vec{A} \quad (4.1)$$

The electric flux  $\Phi$  has a unit of  $\text{N}\cdot\text{m}^2/\text{C}$ .

**Case Two**

*The electric flux for a plan surface make an angle  $\theta$  to a uniform electric field (figure 4.2)*

Note that the number of lines that cross-area is equal to the number that cross the projected area  $A'$ , which is perpendicular to the field. From the figure we see that the two area are related by  $A' = A \cos \theta$ . The flux is given by:

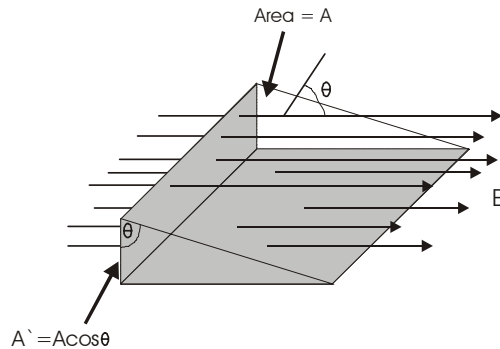

$$\Phi = \vec{E} \cdot \vec{A}' = E A \cos \theta$$

$$\Phi = \vec{E} \cdot \vec{A}$$

Figure 4.2

Where  $\theta$  is the angle between the electric field  $E$  and the normal to the surface  $\vec{A}$ .

$$\theta = 0$$

$$\vec{A} \quad \theta = 90$$

**Case Three**

*In general the electric field is nonuniform over the surface (figure 4.3)*

The flux is calculated by integrating the normal component of the field over the surface in question.

$$\Phi = \oint \vec{E} \cdot \vec{A} \quad (4.2)$$

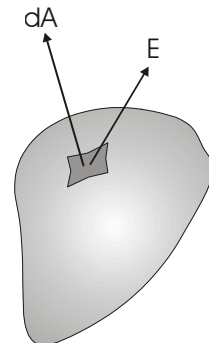

Figure 4.3

The **net flux** through the surface is proportional to the **net number of lines** penetrating the surface

) net number of lines  
 .( ) - (



**Example 4.1**

What is electric flux  $\Phi$  for closed cylinder of radius  $R$  immersed in a uniform electric field as shown in figure 4.4?

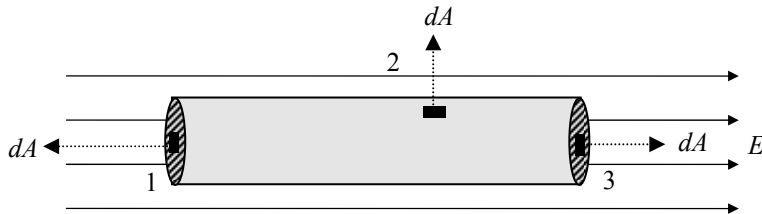

Figure 4.4



**Solution**

$$\begin{aligned} \Phi &= \oint \vec{E} \cdot d\vec{A} = \oint_{(1)} \vec{E} \cdot d\vec{A} + \oint_{(2)} \vec{E} \cdot d\vec{A} + \oint_{(3)} \vec{E} \cdot d\vec{A} \\ &= \oint_{(1)} E \cos 180 dA + \oint_{(2)} E \cos 90 dA + \oint_{(3)} E \cos 0 dA \end{aligned}$$

Since  $E$  is constant then

$$\Phi = -EA + 0 + EA = \text{zero}$$

**Exercise**

Calculate the total flux for a cube immersed in uniform electric field  $\vec{E}$ .

## 4.2 The Electric Flux due to a point charge

To calculate the electric flux due to a point charge we consider an imaginary closed spherical surface with the point charge in the center figure 4.5, this surface is called **gaussian surface**. Then the flux is given by

$$\Phi = \oint \vec{E} \cdot d\vec{A} = E \oint dA \cos\theta \quad (\theta = 0)$$

$$\Phi = \frac{q}{4\pi\epsilon_0 r^2} \int dA = \frac{q}{4\pi\epsilon_0 r^2} 4\pi r^2$$

$$\Phi = \frac{q}{\epsilon_0} \quad (4.3)$$

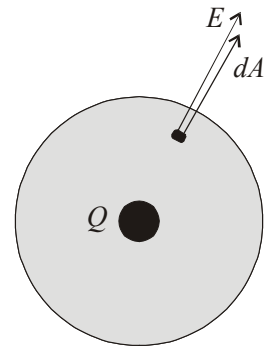

Figure 4.5

Note that the net flux through a spherical gaussian surface is proportional to the charge  $q$  inside the surface.

## 4.3 Gaussian surface

Consider several closed surfaces as shown in figure 4.6 surrounding a charge  $Q$  as in the figure below. The flux that passes through surfaces  $S_1$ ,  $S_2$  and  $S_3$  all has a value  $q/\epsilon_0$ . Therefore we conclude that the net flux through any closed surface is independent of the shape of the surface.

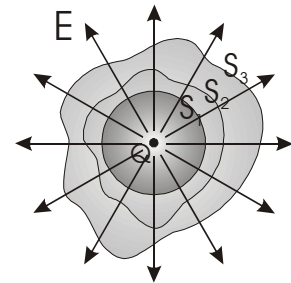

Figure 4.6

Consider a point charge located outside a closed surface as shown in figure 4.7. We can see that the number of electric field lines entering the surface equal the number leaving the surface. Therefore the net electric flux in this case is zero, because the surface surrounds no electric charge.

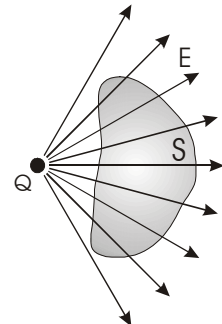

Figure 4.7



**Example 4.2**

In figure 4.8 two equal and opposite charges of  $2Q$  and  $-2Q$  what is the flux  $\Phi$  for the surfaces  $S_1, S_2, S_3$  and  $S_4$ .



**Solution**

For  $S_1$  the flux  $\Phi = \text{zero}$

For  $S_2$  the flux  $\Phi = \text{zero}$

For  $S_3$  the flux  $\Phi = +2Q / \epsilon_0$

For  $S_4$  the flux  $\Phi = -2Q / \epsilon_0$

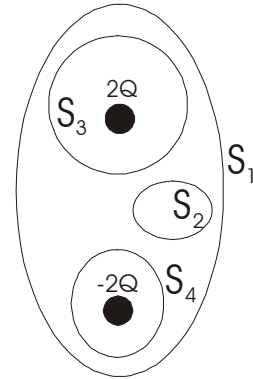

Figure 4.8

---

### 4.4 Gauss's Law

Gauss law is a very powerful theorem, which relates any charge distribution to the resulting electric field at any point in the vicinity of the charge. As we saw the electric field lines means that each charge  $q$  must have  $q/\epsilon_0$  flux lines coming from it. This is the basis for an important equation referred to as **Gauss's law**. Note the following facts:

1. If there are charges  $q_1, q_2, q_3, \dots, q_n$  inside a closed (gaussian) surface, the total number of flux lines coming from these charges will be

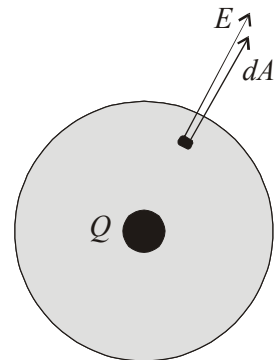

Figure 4.9

$$(q_1 + q_2 + q_3 + \dots + q_n) / \epsilon_0 \quad (4.4)$$



2. The number of flux lines coming out of a closed surface is the integral of  $\vec{E} \cdot d\vec{A}$  over the surface,  $\oint \vec{E} \cdot d\vec{A}$

We can equate both equations to get Gauss law which state that the net electric flux through a closed gaussian surface is equal to the net charge inside the surface divided by  $\epsilon_0$

$$\oint \vec{E} \cdot d\vec{A} = \frac{q_{in}}{\epsilon_0} \quad \text{Gauss's law} \quad (4.5)$$

where  $q_{in}$  is the total charge inside the gaussian surface.

**Gauss's law states that the net electric flux through any closed gaussian surface is equal to the net electric charge inside the surface divided by the permittivity.**

### 4.5 Gauss's law and Coulomb's law

We can deduce Coulomb's law from Gauss's law by assuming a point charge  $q$ , to find the electric field at point or points a distance  $r$  from the charge we imagine a spherical gaussian surface of radius  $r$  and the charge  $q$  at its center as shown in figure 4.10.

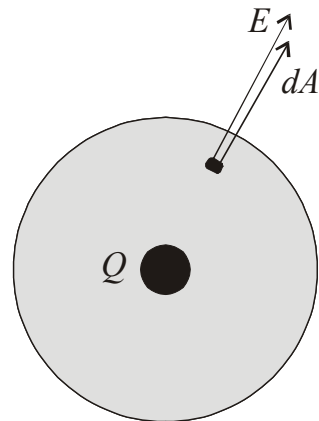

$$\oint \vec{E} \cdot d\vec{A} = \frac{q_{in}}{\epsilon_0}$$

$$\oint E \cos 0 dA = \frac{q_{in}}{\epsilon_0} \quad \text{Because } E \text{ is}$$

constant for all points on the sphere, it can be factored from the inside of the integral sign, then

$$E \oint dA = \frac{q_{in}}{\epsilon_0} \Rightarrow EA = \frac{q_{in}}{\epsilon_0} \Rightarrow E(4\pi r^2) = \frac{q_{in}}{\epsilon_0}$$

$$\therefore E = \frac{1}{4\pi\epsilon_0} \frac{q}{r^2} \quad (4.6)$$

Now put a second point charge  $q_0$  at the point, which  $E$  is calculated. The magnitude of the electric force that acts on it  $F = Eq_0$

$$\therefore F = \frac{1}{4\pi\epsilon_0} \frac{qq_0}{r^2}$$

## 4.6 Conductors in electrostatic equilibrium

A good electrical conductor, such as copper, contains charges (electrons) that are free to move within the material. When there is no net motion of charges within the conductor, the conductor is in electrostatic equilibrium.

**Conductor in electrostatic equilibrium has the following properties:**

1. Any excess charge on an isolated conductor must reside entirely on its surface. *(Explain why?) The answer is when an **excess charge** is placed on a conductor, it will set-up electric field inside the conductor. These fields act on the charge carriers of the conductor (electrons) and cause them to move i.e. current flow inside the conductor. These currents redistribute the **excess charge** on the surface in such away that the internal electric fields reduced to become zero and the currents stop, and the electrostatic conditions restore.*
2. The electric field is zero everywhere inside the conductor. *(Explain why?) Same reason as above*

In figure 4.11 it shows a conducting slab in an external electric field  $E$ . The charges induced on the surface of the slab produce an electric field, which opposes the external field, giving a resultant field of zero in the conductor.

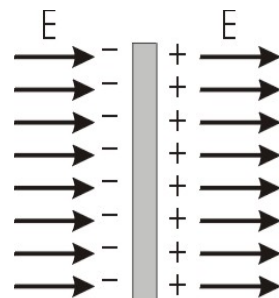
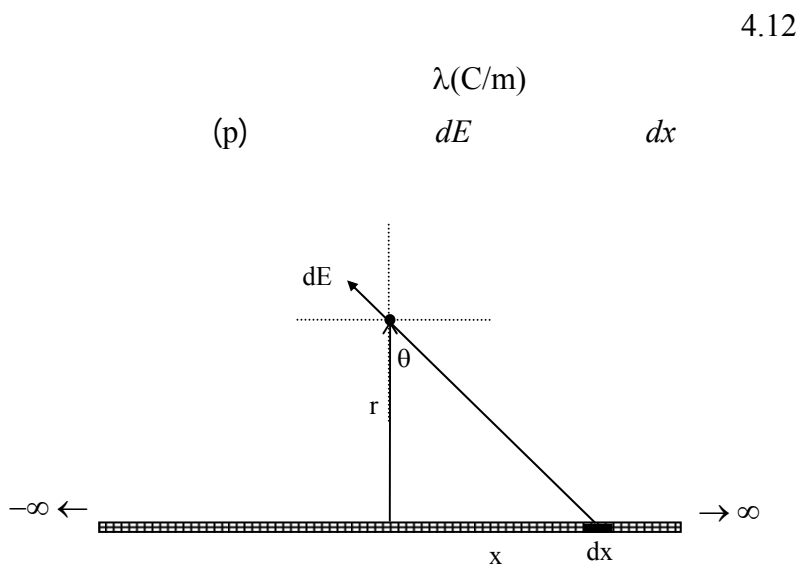

*Figure 4.11*

### **Steps which should be followed in solving problems**

1. The gaussian surface should be chosen to have the same symmetry as the charge distribution.
2. The dimensions of the surface must be such that the surface includes the point where the electric field is to be calculated.
3. From the symmetry of the charge distribution, determine the direction of the electric field and the surface area vector  $dA$ , over the region of the gaussian surface.
4. Write  $E \cdot dA$  as  $E dA \cos\theta$  and divide the surface into separate regions if necessary.
5. The total charge enclosed by the gaussian surface is  $dq = \int dq$ , which is represented in terms of the charge density (  $dq = \lambda dx$  for line of charge,  $dq = \sigma dA$  for a surface of charge,  $dq = \rho dv$  for a volume of charge).

## 4.7 Applications of Gauss's law



*Figure 4.12*

$$dE = K \frac{dq}{r^2 + x^2} = K \frac{\lambda dx}{r^2 + x^2}$$

y

$$dE_y = dE \cos\theta \quad E_y = \int_{-\infty}^{+\infty} dE_y = \int_{-\infty}^{+\infty} \cos\theta dE$$

$$E = 2 \int_0^{+\infty} \cos \theta dE \quad \frac{2\lambda}{4\pi\epsilon_0} \int_0^{+\infty} \cos \theta \frac{dx}{r^2 + x^2}$$

:      dx      x

$$x = y \tan \theta \quad \Rightarrow \quad dx = y \sec^2 \theta d\theta$$

$$E = \frac{\lambda}{2\pi\epsilon_0} \int_0^{\pi/2} \cos \theta d\theta \quad \leftarrow$$

$$E = \frac{\lambda}{2\pi\epsilon_0 r}$$

**Gauss's law can be used to calculate the electric field if the symmetry of the charge distribution is high. Here we concentrate in three different ways of charge distribution**

	1	2	3
<b>Charge distribution</b>	Linear	Surface	Volume
<b>Charge density</b>	$\lambda$	$\sigma$	$\rho$
<b>Unit</b>	C/m	C/m <sup>2</sup>	C/m <sup>3</sup>

**A linear charge distribution**

In figure 4.13 calculate the electric field at a distance  $r$  from a uniform positive line charge of infinite length whose charge per unit length is  $\lambda = \text{constant}$ .

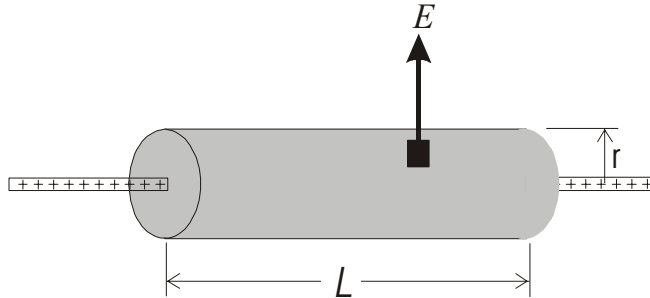

*Figure 4.13*

The electric field  $E$  is perpendicular to the line of charge and directed outward. Therefore for symmetry we select a cylindrical gaussian surface of radius  $r$  and length  $L$ .

The electric field is constant in magnitude and perpendicular to the surface.

The flux through the end of the gaussian cylinder is zero since  $E$  is parallel to the surface.

The total charge inside the gaussian surface is  $\lambda L$ .

Applying Gauss law we get

$$\oint \vec{E} \cdot d\vec{A} = \frac{q_{in}}{\epsilon_o}$$
$$E \oint dA = \frac{\lambda L}{\epsilon_o}$$
$$E 2\pi r L = \frac{\lambda L}{\epsilon_o}$$
$$\therefore E = \frac{\lambda}{2\pi\epsilon_o r} \quad (4.7)$$

### A surface charge distribution

In figure 4.4 calculate the electric field due to non-conducting, infinite plane with uniform charge per unit area  $\sigma$ .

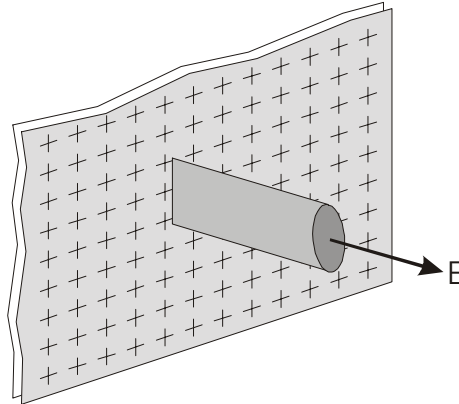

Figure 4.14

The electric field  $E$  is constant in magnitude and perpendicular to the plane charge and directed outward for both surfaces of the plane. Therefore for symmetry we select a cylindrical gaussian surface with its axis is perpendicular to the plane, each end of the gaussian surface has area  $A$  and are equidistance from the plane.

The flux through the end of the gaussian cylinder is  $EA$  since  $E$  is perpendicular to the surface.

The total electric flux from both ends of the gaussian surface will be  $2EA$ .  
Applying Gauss law we get

$$\oint \vec{E} \cdot d\vec{A} = \frac{q_{in}}{\epsilon_0}$$

$$2EA = \frac{\sigma A}{\epsilon_0}$$

$$\therefore E = \frac{\sigma}{2\epsilon_0} \quad (4.8)$$

**An insulated conductor.**

$$E = \frac{\sigma}{\epsilon_0} \quad (4.9)$$

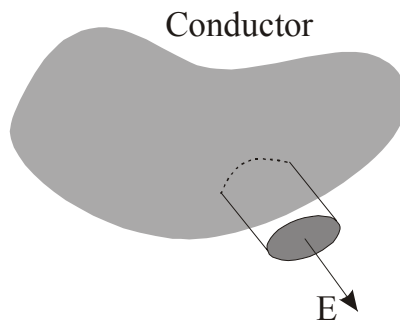

*Figure 4.15*

4.15



### A volume charge distribution

In figure 4.16 shows an insulating sphere of radius  $a$  has a uniform charge density  $\rho$  and a total charge  $Q$ .

- 1) Find the electric field at point outside the sphere ( $r > a$ )
- 2) Find the electric field at point inside the sphere ( $r < a$ )

For  $r > a$

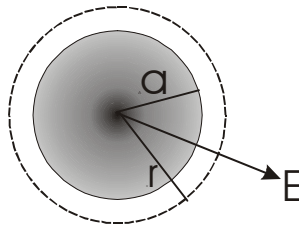

Figure 4.16

We select a spherical gaussian surface of radius  $r$ , concentric with the charge sphere where  $r > a$ . The electric field  $E$  is perpendicular to the gaussian surface as shown in figure 4.16. Applying Gauss law we get

$$\oint \vec{E} \cdot d\vec{A} = \frac{q_{in}}{\epsilon_0}$$
$$E \oint A = E(4\pi r^2) = \frac{Q}{\epsilon_0}$$
$$\therefore E = \frac{Q}{4\pi\epsilon_0 r^2} \quad (\text{for } r > a) \quad (4.10)$$

Note that the result is identical to a point charge.

For  $r < a$

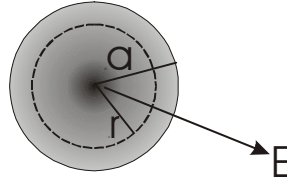

*Figure 4.17*

We select a spherical gaussian surface of radius  $r$ , concentric with the charge sphere where  $r < a$ . The electric field  $E$  is perpendicular to the gaussian surface as shown in figure 4.17. Applying Gauss law we get

$$\oint \vec{E} \cdot d\vec{A} = \frac{q_{in}}{\epsilon_o}$$

It is important at this point to see that the charge inside the gaussian surface of volume  $V$  is less than the total charge  $Q$ . To calculate the charge  $q_{in}$ , we use  $q_{in} = \rho V$ , where  $V = \frac{4}{3}\pi r^3$ . Therefore,

$$q_{in} = \rho V = \rho \left(\frac{4}{3}\pi r^3\right) \quad (4.11)$$

$$\begin{aligned} E \oint A &= E(4\pi r^2) = \frac{q_{in}}{\epsilon_o} \\ E &= \frac{q_{in}}{4\pi\epsilon_o r^2} = \frac{\rho \frac{4}{3}\pi r^3}{4\pi\epsilon_o r^2} = \frac{\rho}{3\epsilon_o} r \end{aligned} \quad (4.12)$$

since  $\rho = \frac{Q}{\frac{4}{3}\pi a^3}$

$$\therefore E = \frac{Qr}{4\pi\epsilon_o a^3} \quad (\text{for } r < a) \quad (4.13)$$

Note that the electric field when  $r < a$  is proportional to  $r$ , and when  $r > a$  the electric field is proportional to  $1/r^2$ .

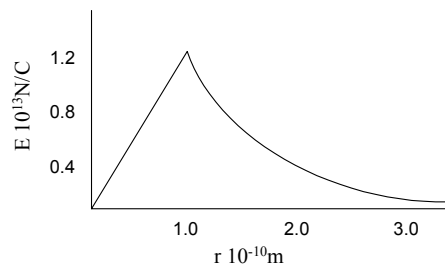

## **4.8 Solution of some selected problems**

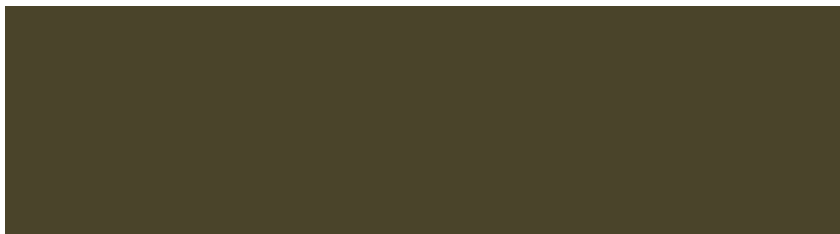

## 4.8 Solution of some selected problems



### Example 4.3

If the net flux through a gaussian surface is zero, which of the following statements are true?

- 1) There are no charges inside the surface.
- 2) The net charge inside the surface is zero.
- 3) The electric field is zero everywhere on the surface.
- 4) The number of electric field lines entering the surface equals the number leaving the surface.



### Solution

Statements (b) and (d) are true. Statement (a) is not necessarily true since Gauss' Law says that the net flux through the closed surface equals the net charge inside the surface divided by  $\epsilon_0$ . For example, you could have an electric dipole inside the surface. Although the net flux may be zero, we cannot conclude that the electric field is zero in that region.



### Example 4.4

A spherical gaussian surface surrounds a point charge  $q$ . Describe what happens to the: flux through the surface if

- 1) The charge is tripled,
- 2) The volume of the sphere is doubled,
- 3) The shape of the surface is changed to that of a cube,
- 4) The charge is moved to another position inside the surface;



### Solution

- 1) If the charge is tripled, the flux through the surface is tripled, since the net flux is proportional to the charge inside the surface
- 2) The flux remains unchanged when the volume changes, since it still surrounds the same amount of charge.
- 3) The flux does not change when the shape of the closed surface changes.

- 4) The flux through the closed surface remains unchanged as the charge inside the surface is moved to another position. All of these conclusions are arrived at through an understanding of Gauss' Law.



**Example 4.5**

A solid conducting sphere of radius  $a$  has a net charge  $+2Q$ . A conducting spherical shell of inner radius  $b$  and outer radius  $c$  is concentric with the solid sphere and has a net charge  $-Q$  as shown in figure 4.18. Using Gauss's law find the electric field in the regions labeled 1, 2, 3, 4 and find the charge distribution on the spherical shell.

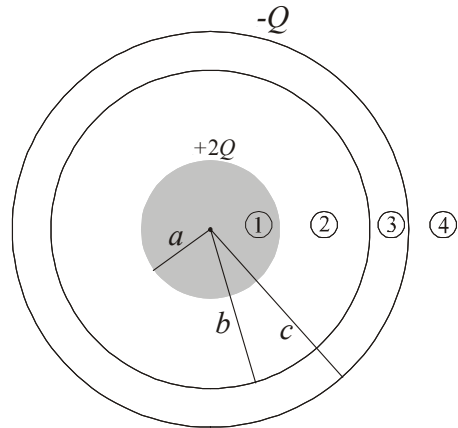

Figure 4.18



**Solution**

$r$

**Region (1)  $r < a$**

To find the  $E$  inside the solid sphere of radius  $a$  we construct a gaussian surface of radius  $r < a$

$E = 0$  since no charge inside the gaussian surface.

**Region (2)  $a < r < b$**

we construct a spherical gaussian surface of radius  $r$

$$\oint \vec{E} \cdot d\vec{A} = \frac{q_{in}}{\epsilon_o}$$

$$2Q$$

$$\theta = 0$$

$$E 4\pi r^2 = \frac{2Q}{\epsilon_0}$$

$$\therefore E = \frac{1}{4\pi\epsilon_0} \frac{2Q}{r^2} \quad a < r < b$$

**Region (4)  $r > c$**

we construct a spherical gaussian surface of radius  $r > c$ , the total net charge inside the gaussian surface is  $q = 2Q + (-Q) = +Q$  Therefore Gauss's law gives

$$\oint \vec{E} \cdot d\vec{A} = \frac{q_{in}}{\epsilon_0}$$

$$E 4\pi r^2 = \frac{Q}{\epsilon_0}$$

$$\therefore E = \frac{1}{4\pi\epsilon_0} \frac{Q}{r^2} \quad r > c$$

**Region (3)  $b > r > c$**

$$-Q$$

$$b < r < c$$

$$-Q$$

$$-2Q$$

$$-Q$$

$$+Q$$



**Example 4.6**

A long straight wire is surrounded by a hollow cylinder whose axis coincides with that wire as shown in figure 4.19. The solid wire has a charge per unit length of  $+\lambda$ , and the hollow cylinder has a *net* charge per unit length of  $+2\lambda$ . Use Gauss law to find (a) the charge per unit length on the inner and outer surfaces of the hollow cylinder and (b) the electric field outside the hollow cylinder, a distance  $r$  from the axis.



**Solution**

(a) Use a cylindrical Gaussian surface  $S_1$  within the conducting cylinder where  $E=0$

$$\oint \vec{E} \cdot d\vec{A} = \frac{q_{in}}{\epsilon_0} = 0$$

and the charge per unit length on the inner surface must be equal to

$$\lambda_{inner} = -\lambda$$

Also  $\lambda_{inner} + \lambda_{outer} = 2\lambda$

thus  $\lambda_{outer} = 3\lambda$

(b) For a gaussian surface  $S_2$  outside the conducting cylinder

$$\oint \vec{E} \cdot d\vec{A} = \frac{q_{in}}{\epsilon_0}$$

$$E (2\pi rL) = \frac{1}{\epsilon_0} (\lambda - \lambda + 3\lambda)L$$

$$\therefore E = \frac{3\lambda}{2\pi\epsilon_0 r}$$

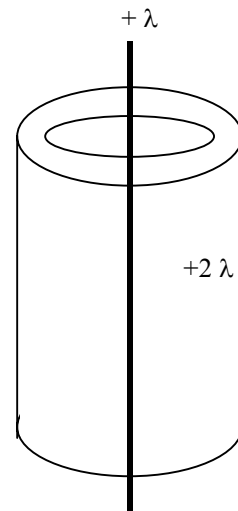

Figure 4.19



**Example 4.7**

Consider a long cylindrical charge distribution of radius  $R$  with a uniform charge density  $\rho$ . Find the electric field at distance  $r$  from the axis where  $r < R$ .



**Solution**

If we choose a cylindrical gaussian surface of length  $L$  and radius  $r$ , Its volume is  $\pi r^2 L$ , and it encloses a charge  $\rho \pi r^2 L$ . By applying Gauss's law we get,

$$\oint \vec{E} \cdot d\vec{A} = \frac{q_{in}}{\epsilon_0} \quad \text{becomes} \quad E \oint dA = \frac{\rho \pi r^2 L}{\epsilon_0}$$

$$\because \oint dA = 2\pi r L \quad \text{therefore} \quad E(2\pi r L) = \frac{\rho \pi r^2 L}{\epsilon_0}$$

Thus

$$E = \frac{\rho r}{2\epsilon_0} \quad \text{radially outward from the cylinder axis}$$

Notice that the electric field will increase as  $\rho$  increases, and also the electric field is proportional to  $r$  for  $r < R$ . For the region outside the cylinder ( $r > R$ ), the electric field will decrease as  $r$  increases.





**Example 4.8**

Two large non-conducting sheets of +ve charge face each other as shown in figure 4.20. What is  $E$  at points (i) to the left of the sheets (ii) between them and (iii) to the right of the sheets?



**Solution**

We know previously that for each sheet, the magnitude of the field at any point is

$$E = \frac{\sigma}{2\epsilon_0}$$

(a) At point to the left of the two parallel sheets

$$E = -E_1 + (-E_2) = -2E$$

$$\therefore E = -\frac{\sigma}{\epsilon_0}$$

(b) At point between the two sheets

$$E = E_1 + (-E_2) = \text{zero}$$

(c) At point to the right of the two parallel sheets

$$E = E_1 + E_2 = 2E$$

$$\therefore E = \frac{\sigma}{\epsilon_0}$$

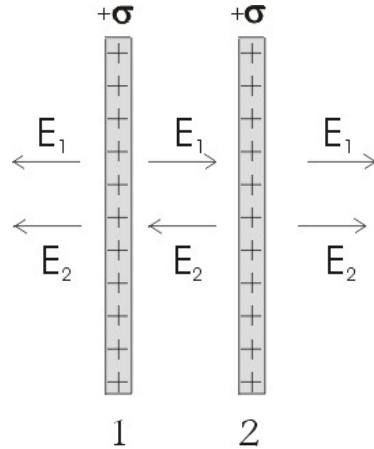
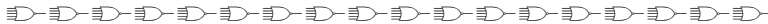

Figure 4.20



## 4.9 Problems

---

4.1) An electric field of intensity  $3.5 \times 10^3 \text{ N/C}$  is applied the x-axis. Calculate the electric flux through a rectangular plane 0.35m wide and 0.70m long if (a) the plane is parallel to the yz plane, (b) the plane is parallel to the xy plane, and (c) the plane contains the y axis and its normal makes an angle of  $40^\circ$  with the x axis.

4.2) A point charge of  $+5 \mu\text{C}$  is located at the center of a sphere with a radius of 12cm. What is the electric flux through the surface of this sphere?

4.3) (a) Two charges of  $8 \mu\text{C}$  and  $-5 \mu\text{C}$  are inside a cube of sides 0.45m. What is the total electric flux through the cube? (b) Repeat (a) if the same two charges are inside a spherical shell of radius 0.45 m.

4.4) The electric field everywhere on the surface of a hollow sphere of radius 0.75m is measured to be equal to  $8.90 \times 10^2 \text{ N/C}$  and points radially toward the center of the sphere. (a) What is the net charge within the surface? (b) What can you conclude about charge inside the nature and distribution of the charge inside the sphere?

4.5) Four closed surfaces,  $S_1$ , through  $S_4$ , together with the charges  $-2Q$ ,  $+Q$ , and  $-Q$  are sketched in figure 4.21. Find the electric flux through each surface.

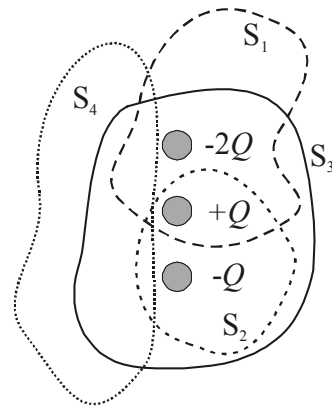

*Figure 4.21*

4.6) A conducting spherical shell of radius 15cm carries a net charge of  $-6.4 \mu\text{C}$  uniformly distributed on its surface. Find the electric field at points (a) just outside the shell and (b) inside the shell.

4.7) A long, straight metal rod has a radius of 5cm and a charge per unit length of  $30 \text{ nC/m}$ . Find the electric field at the following distances from the axis of the rod: (a) 3cm, (b) 10cm, (c) 100cm.

4.8) A square plate of copper of sides 50cm is placed in an extended electric field of  $8 \times 10^4 \text{ N/C}$  directed perpendicular to the plate. Find (a) the charge density of each face of the plate and (b) the total charge on each face.

4.9) A solid copper sphere 15cm in radius has a total charge of 40nC. Find the electric field at the following distances measured from the center of the sphere: (a) 12cm, (b) 17cm, (c) 75cm. (d) How would your answers change if the sphere were hollow?

4.10) A solid conducting sphere of radius 2cm has a positive charge of  $+8\mu\text{C}$ . A conducting spherical shell of inner radius 4cm and outer radius 5cm is concentric with the solid sphere and has a net charge of  $-4\mu\text{C}$ . (a) Find the electric field at the following distances from the center of this charge configuration: (a)  $r=1\text{cm}$ , (b)  $r=3\text{cm}$ , (c)  $r=4.5\text{cm}$ , and (d)  $r=7\text{cm}$ .

4.11) A non-conducting sphere of radius  $a$  is placed at the center of a spherical conducting shell of inner radius  $b$  and outer radius  $c$ . A charge  $+Q$  is distributed uniformly through the inner sphere (charge density  $\rho\text{C/m}^3$ ) as shown in figure 4.22. The outer shell carries  $-Q$ . Find  $E(r)$  (i) within the sphere ( $r < a$ ) (ii) between the sphere and the shell ( $a < r < b$ ) (iii) inside the shell ( $b < r < c$ ) and (iv) outside the

shell and (v) What is the charge appear on the inner and outer surfaces of the shell?

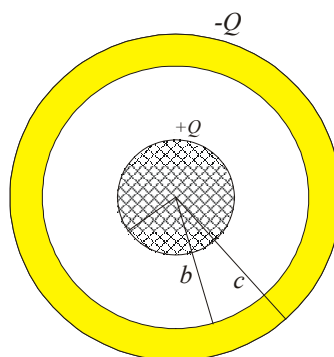

Figure 4.22

4.12) A solid sphere of radius 40cm has a total positive charge of  $26\mu\text{C}$  uniformly distributed throughout its volume. Calculate the electric field intensity at the following distances from the center of the sphere: (a) 0 cm, (b) 10cm, (c) 40cm, (d) 60 cm.

4.13) An insulating sphere is 8cm in diameter, and carries a  $+5.7\mu\text{C}$  charge uniformly distributed throughout its interior volume. Calculate the charge enclosed by a concentric spherical surface with the following radii: (a)  $r=2\text{cm}$  and (b)  $r=6\text{cm}$ .

4.14) A long conducting cylinder (length  $l$ ) carry a total charge  $+q$  is surrounded by a conducting cylindrical shell of total charge  $-2q$  as shown in figure 4.23. Use

## Electric Flux

---

Gauss's law to find (i) the electric field at points outside the conducting shell and inside the conducting shell, (ii) the distribution of the charge on the conducting shell, and (iii) the electric field in the region between the cylinder and the cylindrical shell?

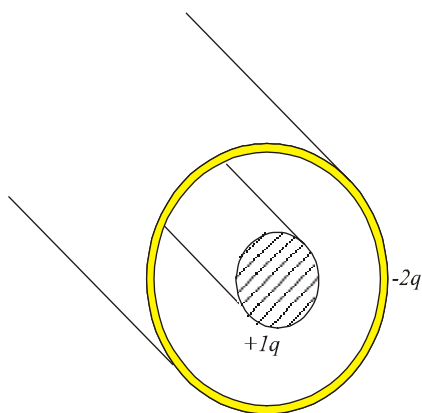

*Figure 4.23*

- 4.15) Consider a thin spherical shell of radius 14cm with a total charge of  $32\mu\text{C}$  distributed uniformly on its surface. Find the electric field for the following distances from the center of the charge distribution: (a)  $r=10\text{cm}$  and (b)  $r=20\text{cm}$ .

- 4.16) A large plane sheet of charge has a charge per unit area of  $9.0\mu\text{C}/\text{m}^2$ . Find the electric field intensity just above the surface of the sheet, measured from the sheet's midpoint.
- 4.17) Two large metal plates face each other and carry charges with surface density  $+\sigma$  and  $-\sigma$  respectively, on their inner surfaces as shown in figure 4.24. What is  $E$  at points (i) to the left of the sheets (ii) between them and (iii) to the right of the sheets?

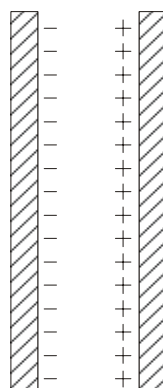

*Figure 4.24*

**LECTURES IN GENERAL PHYSICS**

# *Electrostatic*

*Principles and Applications*

Dr. Hazem Falah Sakeek

Al-Azhar University - Gaza

*Part Two*

# Chapter 5

# Electric Potential

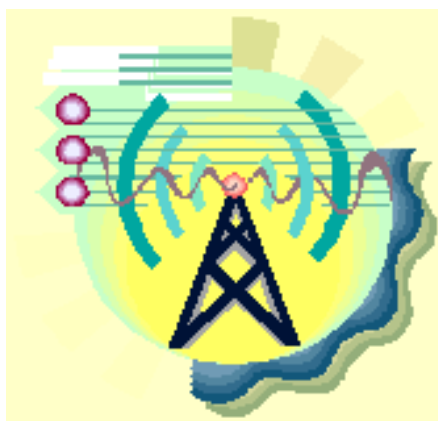

# Electric Potential

**5.1 Definition of electric potential difference**

**5.2 The Equipotential surfaces**

**5.3 Electric Potential and Electric Field**

**5.4 Potential difference due to a point charge**

**5.5 The potential due to a point charge**

**5.6 The potential due to a point charge**

**5.7 Electric Potential Energy**

**5.8 Calculation of E from V**

**5.9 Problems**

# The Electric Potential

The electric potential

-:

(1)

(2)

(3)

(4)

(5)



(1)

( )

$h$   $m$

$m$

$m$

$h$

(2)

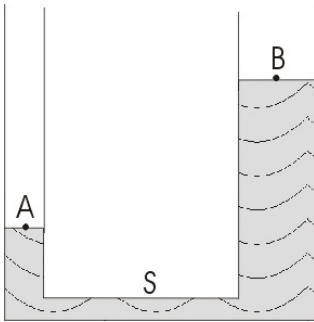

Figure 5.1

5.1

$U$

B

S

A

A

A&B

(3)

A&B

5.2

$Q$

$m$

$q_0$

$q_0$

$Q$

(

B

A

B

$q_0$

## Electric Potential Difference

---

$E$

A&B

$(qE)$

$(F_{ex})$

.

)

B

A

$q_0$

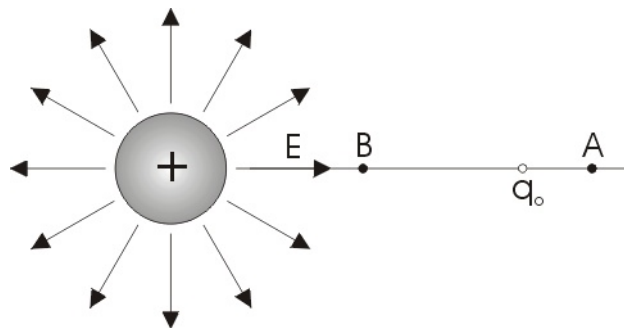

*Figure 5.2*

1.5volt

U

## 5.1 Definition of electric potential difference

We define the potential difference between two points  $A$  and  $B$  as the work done by an external agent in moving a test charge  $q_0$  from  $A$  to  $B$  *i.e.*

$$V_B - V_A = W_{AB} / q_0 \quad (5.1)$$

The unit of the potential difference is (**Joule/Coulomb**) which is known as **Volt (V)**

### Notice

Since the work may be (a) positive *i.e.*  $V_B > V_A$

(b) negative *i.e.*  $V_B < V_A$

(c) zero *i.e.*  $V_B = V_A$

You should remember that the work equals

$$W = \vec{F}_{ex} \cdot \vec{l} = F_{ex} \cos \theta l$$

- If  $0 < \theta < 90 \Rightarrow \cos \theta$  is +ve and therefore the  $W$  is +ve
- If  $90 < \theta < 180 \Rightarrow \cos \theta$  is -ve and therefore  $W$  is -ve
- If  $\theta = 90$  between  $F_{ex}$  and  $l \Rightarrow$  therefore  $W$  is zero

The potential difference is independent on the path between  $A$  and  $B$ . Since the work ( $W_{AB}$ ) done to move a test charge  $q_0$  from  $A$  to  $B$  is independent on the path, otherwise the work is not a scalar quantity. (see example 5.2)

## 5.2 The Equipotential surfaces

As the electric field can be represented graphically by lines of force, the potential distribution in an electric field may be represented graphically by equipotential surfaces.

*The equipotential surface* is a surface such that the potential has the same value at all points on the surface. *i.e.*  $V_B - V_A = \text{zero}$  for any two points on one surface.

The work is required to move a test charge between any two points on an equipotential surface is zero. (*Explain why?*)

In all cases the equipotential surfaces are at right angles to the lines of force and thus to  $E$ . (*Explain why?*)

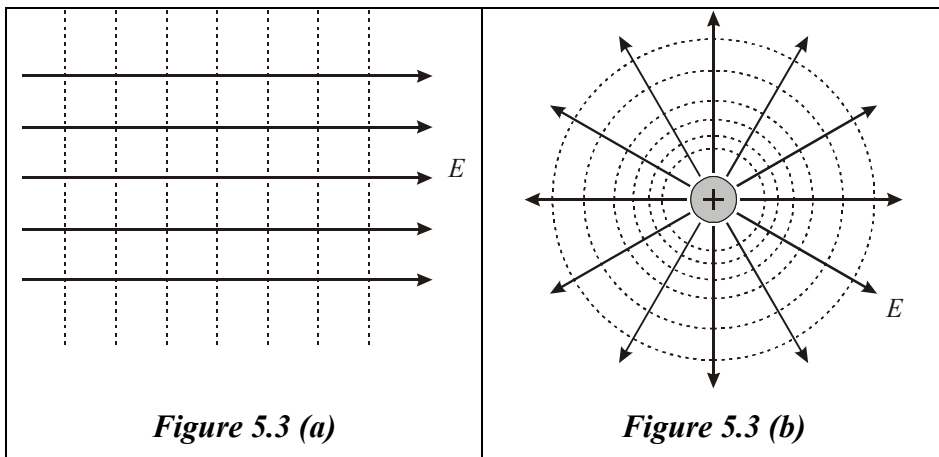

*Figure 5.3 shows the equipotential surfaces (dashed lines) and the electric field lines (bold lines), (a) for uniform electric field and (b) for electric field due to a positive charge.*

## 5.3 Electric Potential and Electric Field

### Simple Case (Uniform electric field):

The potential difference between two points  $A$  and  $B$  in a Uniform electric field  $E$  can be found as follow,

Assume that a positive test charge  $q_o$  is moved by an external agent from  $A$  to  $B$  in uniform electric field as shown in figure 5.4.

The test charge  $q_o$  is affected by electric force of  $q_oE$  in the downward direction. To move the charge from  $A$  to  $B$  an external force  $F$  of the same magnitude to the electric force but in the opposite direction. The work  $W$  done by the external agent is:

$$W_{AB} = Fd = q_oEd \quad (5.2)$$

The potential difference  $V_B - V_A$  is

$$V_B - V_A = \frac{W_{AB}}{q_o} = Ed \quad (5.3)$$

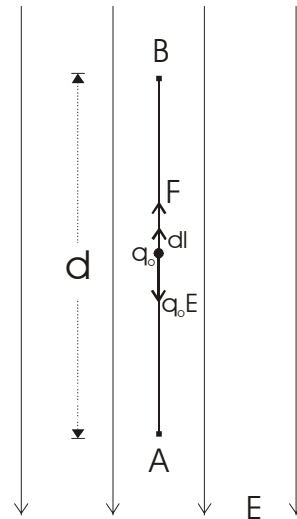

Figure 5.4

This equation shows the relation between the potential difference and the electric field for a special case (uniform electric field). Note that  $E$  has a new unit (V/m). hence,

$$\frac{Volt}{Meter} = \frac{Newton}{Coulomb}$$

**The relation in general case (not uniform electric field):**

If the test charge  $q_0$  is moved along a curved path from  $A$  to  $B$  as shown in figure 5.5. The electric field exerts a force  $q_0E$  on the charge. To keep the charge moving without accelerating, an external agent must apply a force  $F$  equal to  $-q_0E$ .

If the test charge moves distance  $dl$  along the path from  $A$  to  $B$ , the work done is  $F \cdot dl$ . The total work is given by,

$$W_{AB} = \int_A^B \vec{F} \cdot d\vec{l} = -q_0 \int_A^B \vec{E} \cdot d\vec{l} \quad (5.4)$$

The potential difference  $V_B - V_A$  is,

$$V_B - V_A = \frac{W_{AB}}{q_0} = - \int_A^B \vec{E} \cdot d\vec{l} \quad (5.5)$$

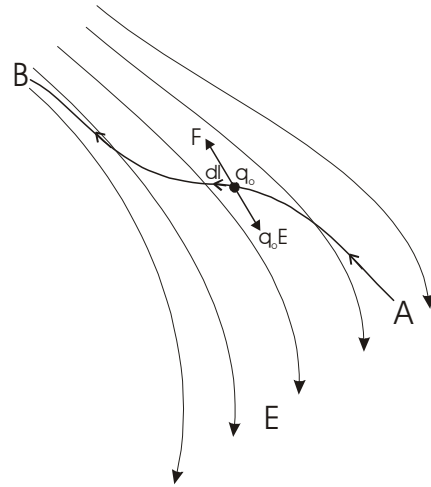

*Figure 5.5*

$$dl \qquad \qquad \qquad B \quad A \qquad \qquad \qquad \theta$$

If the point  $A$  is taken to infinity then  $V_A=0$  the potential  $V$  at point  $B$  is,

$$V_B = - \int_{\infty}^B \vec{E} \cdot d\vec{l} \quad (5.6)$$

This equation gives the general relation between the potential and the electric field.



**Example 5.1**

Derive the potential difference between points  $A$  and  $B$  in uniform electric field using the general case.



**Solution**

$$V_B - V_A = -\int_A^B \vec{E} \cdot d\vec{l} = -\int_A^B E \cos 180^\circ dl = \int_A^B Edl \quad (5.7)$$

$E$  is uniform (constant) and the integration over the path  $A$  to  $B$  is  $d$ , therefore

$$V_B - V_A = E \int_A^B dl = Ed \quad (5.8)$$



**Example 5.2**

In figure 5.6 the test charge moved from  $A$  to  $B$  along the path shown. Calculate the potential difference between  $A$  and  $B$ .

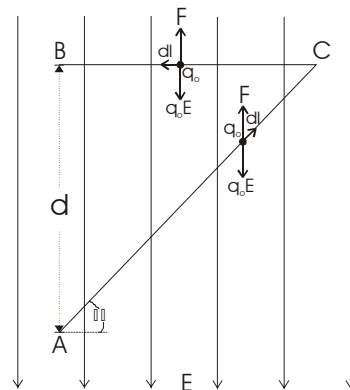

Figure 5.6



### Solution

$$V_B - V_A = (V_B - V_C) + (V_C - V_A)$$

For the path  $AC$  the angle  $\theta$  is  $135^\circ$ ,

$$V_C - V_A = -\int_A^C \vec{E} \cdot d\vec{l} = -\int_A^C E \cos 135^\circ dl = \frac{E}{\sqrt{2}} \int_A^C dl$$

The length of the line  $AC$  is  $\sqrt{2} d$

$$V_C - V_A = \frac{E}{\sqrt{2}} (\sqrt{2} d) = Ed$$

For the path  $CB$  the work is zero and  $E$  is perpendicular to the path therefore,  $V_C - V_B = 0$

$$V_B - V_A = V_C - V_A = Ed$$

---

---

### The Electron Volt Unit

A widely used unit of energy in atomic physics is the electron volt (eV). **ELECTRON VOLT**, unit of energy, used by physicists to express the energy of ions and subatomic particles that have been accelerated in particle accelerators. One electron volt is equal to the amount of energy gained by an electron traveling through an electrical potential difference of 1 V; this is equivalent to  $1.60207 \times 10^{-19}$  J. Electron volts are commonly expressed as million electron volts (MeV) and billion electron volts (BeV or GeV).



## 5.4 Potential difference due to a point charge

Assume two points  $A$  and  $B$  near to a positive charge  $q$  as shown in figure 5.7. To calculate the potential difference  $V_B - V_A$  we assume a test charge  $q_0$  is moved without acceleration from  $A$  to  $B$ .

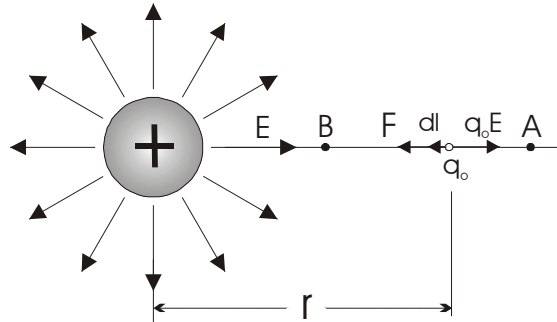

Figure 5.7

In the figure above the electric field  $E$  is directed to the right and  $dl$  to the left.

$$\vec{E} \cdot d\vec{l} = E \cos 180^\circ dl = -Edl \quad (5.10)$$

However when we move a distance  $dl$  to the left, we are moving in a direction of decreasing  $r$ . Thus

$$d\vec{l} = -d\vec{r} \quad (5.11)$$

Therefore

$$-Edl = Edr \quad (5.12)$$

$$\therefore V_B - V_A = -\int_A^B \vec{E} \cdot d\vec{l} = \int_{r_A}^{r_B} \vec{E} \cdot d\vec{r} \quad (5.13)$$

Substitute for  $E$

$$\therefore E = \frac{1}{4\pi\epsilon_0} \frac{q}{r^2} \quad (5.14)$$

We get

$$\therefore V_B - V_A = -\frac{q}{4\pi\epsilon_0} \int_{r_A}^{r_B} \frac{dr}{r^2} = \frac{q}{4\pi\epsilon_0} \left( \frac{1}{r_B} - \frac{1}{r_A} \right) \quad (5.15)$$

.q

### 5.5 The potential due to a point charge

If we choose  $A$  at infinity then  $V_A=0$  (i.e.  $r_A \Rightarrow \infty$ ) this lead to the potential at distance  $r$  from a charge  $q$  is given by

$$V = \frac{1}{4\pi\epsilon_0} \frac{q}{r} \quad (5.16)$$

This equation shows that the equipotential surfaces for a charge are spheres concentric with the charge as shown in figure 5.8.

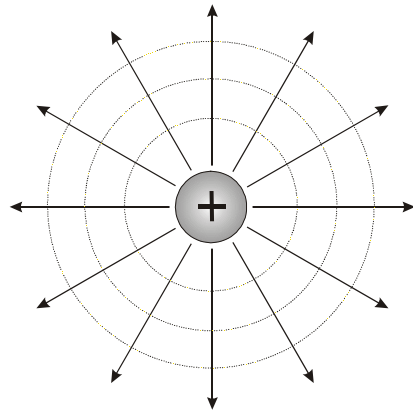

*Figure 5.8*

## 5.6 The potential due to a point charge

$$V = V_1 + V_2 + V_3 + \dots + V_n \quad (5.17)$$

$$\therefore V = \sum_n V_n = \frac{1}{4\pi\epsilon_0} \sum_n \frac{q_n}{r_n} \quad (5.18)$$

$q$



### Example 5.3

What must the magnitude of an isolated positive charge be for the electric potential at 10 cm from the charge to be +100V?



### Solution

$$V = \frac{1}{4\pi\epsilon_0} \frac{q}{r}$$

$$\therefore q = V 4\pi\epsilon_0 r^2 = 100 \times 4\pi \times 8.9 \times 10^{-12} \times 0.1 = 1.1 \times 10^{-9} \text{ C}$$



**Example 5.4**

What is the potential at the center of the square shown in figure 5.9? Assume that  $q_1 = +1 \times 10^{-8} \text{C}$ ,  $q_2 = -2 \times 10^{-8} \text{C}$ ,  $q_3 = +3 \times 10^{-8} \text{C}$ ,  $q_4 = +2 \times 10^{-8} \text{C}$ , and  $a = 1 \text{m}$ .



**Solution**

$$\therefore V = \sum_n V_n = \frac{1}{4\pi\epsilon_0} \frac{q_1 + q_2 + q_3 + q_4}{r}$$

The distance  $r$  for each charge from  $P$  is  $0.71 \text{m}$

$$\therefore V = \frac{9 \times 10^9 (1 - 2 + 3 + 2) \times 10^{-8}}{0.71} = 500 \text{V}$$

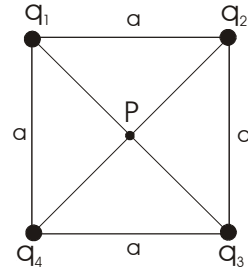
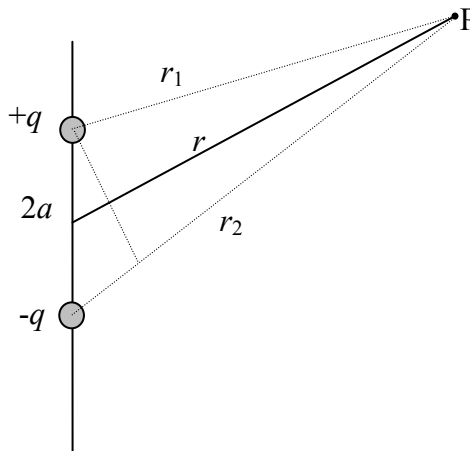

**Figure 5.9**



**Example 5.5**

Calculate the electric potential due to an electric dipole as shown in figure 5.10.



**Figure 5.10**



**Solution**

$$V = \sum V_n = V_1 + V_2$$

$$V = K \left( \frac{q}{r_1} - \frac{q}{r_2} \right) = Kq \frac{r_2 - r_1}{r_2 r_1}$$

When  $r \gg 2a$ ,

$$r_2 - r_1 \cong 2a \cos \theta \quad \text{and} \quad r_1 r_2 \cong r^2,$$

$$V = Kq \frac{2a \cos \theta}{r^2} = K \frac{p \cos \theta}{r^2} \quad (5.19)$$

where  $p$  is the dipole momentum

Note that  $V = 0$  when  $\theta = 90^\circ$  but  $V$  has the maximum positive value when  $\theta = 0^\circ$  and  $V$  has the maximum negative value when  $\theta = 180^\circ$ .

---

---

## 5.7 Electric Potential Energy

The definition of the *electric potential energy* of a system of charges is the work required to bring them from infinity to that configuration.

To work out the electric potential energy for a system of charges, assume a charge  $q_2$  at infinity and at rest as shown in figure 5.11. If  $q_2$  is moved from infinity to a distance  $r$  from another charge  $q_1$ , then the work required is given by

$$W = Vq_2$$

$$\therefore V = \frac{1}{4\pi\epsilon_0} \frac{q_1}{r}$$

Substitute for  $V$  in the equation of work

$$U = W = \frac{1}{4\pi\epsilon_0} \frac{q_1 q_2}{r_{12}} \quad (5.20)$$

$$U = \frac{q_1 q_2}{4\pi\epsilon_0 r} \quad (5.21)$$

To calculate the potential energy for systems containing more than two charges we compute the potential energy for every pair of charges separately and to add the results algebraically.

$$U = \sum \frac{q_i q_j}{4\pi\epsilon_0 r_{ij}} \quad (5.22)$$

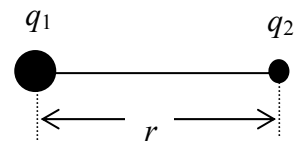

*Figure 5.11*

If the total electric potential energy of a system of charges is positive this correspond to a repulsive electric forces, but if the total electric potential energy is negative this correspond to attractive electric forces. (*explain why?*)



**Example 5.6**

Three charges are held fixed as shown in figure 5.12. What is the potential energy? Assume that  $q=1 \times 10^{-7} \text{C}$  and  $a=10\text{cm}$ .

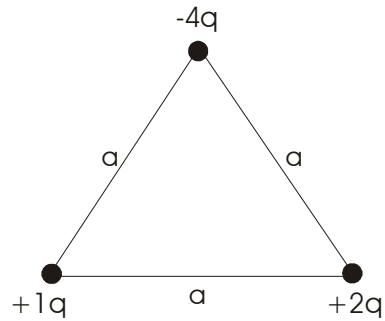

Figure 5.12



**Solution**

$$U=U_{12}+U_{13}+U_{23}$$

$$U = \frac{1}{4\pi\epsilon_0} \left[ \frac{(+q)(-q)}{a} + \frac{(+q)(+2q)}{a} + \frac{(-4q)(+2q)}{a} \right]$$

$$U = -\frac{10}{4\pi\epsilon_0} \frac{q^2}{a}$$

$$\therefore U = -\frac{9 \times 10^9 (10)(1 \times 10^{-7})^2}{0.1} = -9 \times 10^{-3} \text{ J}$$

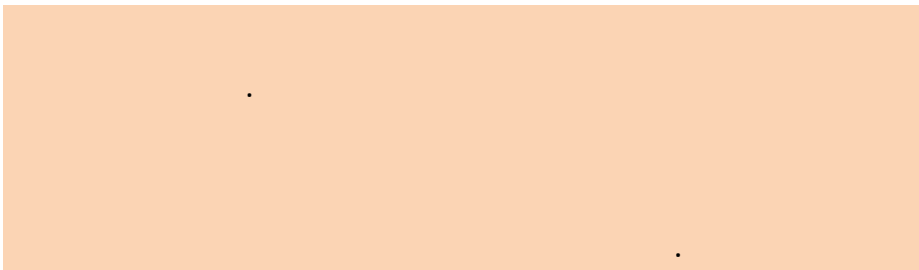

## 5.8 Calculation of $E$ from $V$

As we have learned that both the electric field and the electric potential can be used to evaluate the electric effects. Also we have showed how to calculate the electric potential from the electric field now we determine the electric field from the electric potential by the following relation.

$$\vec{E} = -\frac{dV}{dl} \quad (5.23)$$

New unit for the electric field is *volt/meter* (v/m)

.equipotential surfaces



### Example 5.7

Calculate the electric field for a point charge  $q$ , using the equation

$$V = \frac{1}{4\pi\epsilon_0} \frac{q}{r}$$



### Solution

$$E = -\frac{dV}{dl} = -\frac{d}{dr} \left( \frac{1}{4\pi\epsilon_0} \frac{q}{r} \right)$$

$$E = -\frac{q}{4\pi\epsilon_0} \frac{d}{dr} \left( \frac{1}{r} \right) = \frac{1}{4\pi\epsilon_0} \frac{q}{r^2}$$

---



## **5.9 Solution of some selected problems**

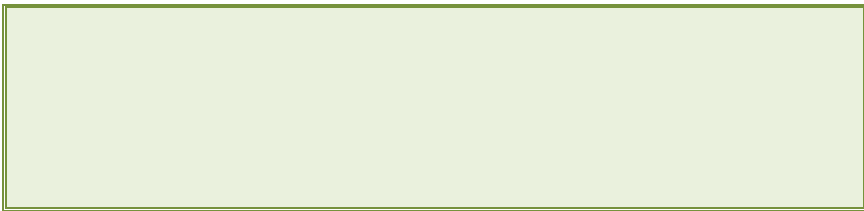



### Example 5.8

Two charges of  $2\mu\text{C}$  and  $-6\mu\text{C}$  are located at positions  $(0,0)$  m and  $(0,3)$  m, respectively as shown in figure 5.13. (i) Find the total electric potential due to these charges at point  $(4,0)$  m.

(ii) How much work is required to bring a  $3\mu\text{C}$  charge from  $\infty$  to the point  $P$ ?

(iii) What is the potential energy for the three charges?

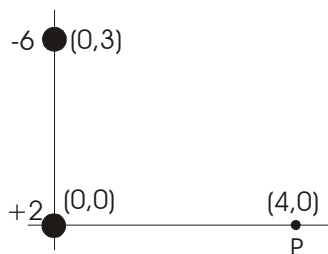

Figure 5.13



### Solution

$$V_p = V_1 + V_2$$

$$V = \frac{1}{4\pi\epsilon_0} \left[ \frac{q_1}{r_1} + \frac{q_2}{r_2} \right]$$

$$V = 9 \times 10^9 \left[ \frac{2 \times 10^{-6}}{4} - \frac{6 \times 10^{-6}}{5} \right] = -6.3 \times 10^3 \text{ volt}$$

(ii) the work required is given by

$$W = q_3 V_p = 3 \times 10^{-6} \times -6.3 \times 10^3 = -18.9 \times 10^{-3} \text{ J}$$

The -ve sign means that work is done by the charge for the movement from  $\infty$  to  $P$ .

(iii) The potential energy is given by

$$U = U_{12} + U_{13} + U_{23}$$

$$U = k \left[ \frac{(2 \times 10^{-6})(-6 \times 10^{-6})}{3} + \frac{(2 \times 10^{-6})(3 \times 10^{-6})}{4} + \frac{(-6 \times 10^{-6})(3 \times 10^{-6})}{5} \right]$$

$$\therefore U = -5.5 \times 10^{-2} \text{ Joule}$$



**Example 5.9**

A particle having a charge  $q=3\times 10^{-9}\text{C}$  moves from point  $a$  to point  $b$  along a straight line, a total distance  $d=0.5\text{m}$ . The electric field is uniform along this line, in the direction from  $a$  to  $b$ , with magnitude  $E=200\text{N/C}$ . Determine the force on  $q$ , the work done on it by the electric field, and the potential difference  $V_a-V_b$ .



**Solution**

The force is in the same direction as the electric field since the charge is positive; the magnitude of the force is given by

$$F=qE=3\times 10^{-9}\times 200=600\times 10^{-9}\text{N}$$

The work done by this force is

$$W=Fd=600\times 10^{-9}\times 0.5=300\times 10^{-9}\text{J}$$

The potential difference is the work per unit charge, which is

$$V_a-V_b=W/q=100\text{V}$$

Or

$$V_a-V_b=Ed=200\times 0.5=100\text{V}$$



**Example 5.10**

Point charge of  $+12\times 10^{-9}\text{C}$  and  $-12\times 10^{-9}\text{C}$  are placed 10cm part as shown in figure 5.14. Compute the potential at point  $a$ ,  $b$ , and  $c$ .

Compute the potential energy of a point charge  $+4\times 10^{-9}\text{C}$  if it placed at points  $a$ ,  $b$ , and  $c$ .

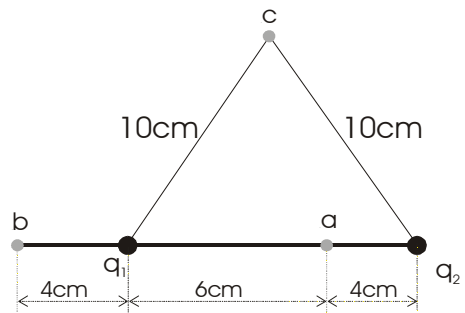

Figure 5.14



### Solution

We need to use the following equation at each point to calculate the potential,

$$V = \sum_n V_n = \frac{1}{4\pi\epsilon_0} \sum \frac{q_i}{r_i}$$

At point a

$$V_a = 9 \times 10^9 \left( \frac{12 \times 10^{-9}}{0.06} + \frac{-12 \times 10^{-9}}{0.04} \right) = -900V$$

At point b

$$V_b = 9 \times 10^9 \left( \frac{12 \times 10^{-9}}{0.04} + \frac{-12 \times 10^{-9}}{0.14} \right) = -1930V$$

At point c

$$V_c = 9 \times 10^9 \left( \frac{12 \times 10^{-9}}{0.1} + \frac{-12 \times 10^{-9}}{0.14} \right) = 0V$$

We need to use the following equation at each point to calculate the potential energy,

$$U = qV$$

At point a

$$U_a = qV_a = 4 \times 10^{-9} \times (-900) = -36 \times 10^{-7}J$$

At point b

$$U_b = qV_b = 4 \times 10^{-9} \times 1930 = +77 \times 10^{-7}J$$

At point c

$$U_c = qV_c = 4 \times 10^{-9} \times 0 = 0$$

**Example 5.11**

A charge  $q$  is distributed throughout a nonconducting spherical volume of radius  $R$ . (a) Show that the potential at a distance  $r$  from the center where  $r < R$ , is given by

$$V = \frac{q(3R^2 - r^2)}{8\pi\epsilon_0 R^3}$$

**Solution**

A

.A

$$V_B - V_\infty = -\int \vec{E} \cdot d\vec{l}$$

$$E_{out} = \frac{q}{4\pi\epsilon_0 r^2} \quad E_{in} = \frac{qr}{4\pi\epsilon_0 R^3}$$

$$V_A - V_\infty = (V_A - V_B) + (V_B - V_\infty)$$

$$V_A - V_\infty = -\int \vec{E}_{in} \cdot d\vec{l} - \int \vec{E}_{out} \cdot d\vec{l}$$

$$dl = -dr \quad \cos 180^\circ = -1 \quad 180^\circ \quad dl \ \& \ E$$

$$\begin{aligned} V_A - V_\infty &= -\int \frac{qr}{4\pi\epsilon_0 R^3} dr - \int \frac{q}{4\pi\epsilon_0 r^2} dr \\ &= -\frac{q}{4\pi\epsilon_0 R^3} \left[ \frac{r^2}{2} \right] + \frac{q}{4\pi\epsilon_0} \left[ \frac{1}{r} \right] = \frac{q(3R^2 - r^2)}{8\pi\epsilon_0 R^3} \end{aligned}$$

A

$$V = \frac{q}{4\pi\epsilon_0 R}$$

A



**Example 5.12**

For the charge configuration shown in figure 5.15, Show that  $V(r)$  for the points on the vertical axis, assuming  $r \gg a$ , is given by

$$V = \frac{1}{4\pi\epsilon_0} \left[ \frac{q}{r} + \frac{2aq}{r^2} \right]$$



**Solution**

$$V_p = V_1 + V_2 + V_3$$

$$V = \frac{q}{4\pi\epsilon_0(r-a)} + \frac{q}{4\pi\epsilon_0 r} - \frac{q}{4\pi\epsilon_0(r+a)}$$

$$\frac{q(r+a) - q(r-a)}{4\pi\epsilon_0(r^2 - a^2)} + \frac{q}{4\pi\epsilon_0 r}$$

$$\frac{2aq}{4\pi\epsilon_0 r^2(1 - a^2/r^2)} + \frac{q}{4\pi\epsilon_0 r}$$

when  $r \gg a$  then  $a^2/r^2 \ll 1$

$$V = \frac{2aq}{4\pi\epsilon_0 r^2} (1 - a^2/r^2)^{-1} + \frac{q}{4\pi\epsilon_0 r}$$

$$(1 + x)^n = 1 + nx \quad \text{when } x \ll 1$$

$$V = \frac{2aq}{4\pi\epsilon_0 r^2} (1 + a^2/r^2) + \frac{q}{4\pi\epsilon_0 r}$$

$$\therefore V = \frac{1}{4\pi\epsilon_0} \left[ \frac{q}{r} + \frac{2aq}{r^2} \right]$$

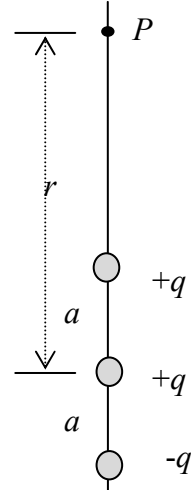

Figure 5.15

$$1 \quad a^2/r^2$$



**Example 5.13**

Derive an expression for the work required to put the four charges together as indicated in figure 5.16.

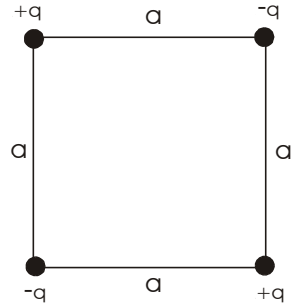

Figure 5.16



**Solution**

The work required to put these charges together is equal to the total electric potential energy.

$$U = U_{12} + U_{13} + U_{14} + U_{23} + U_{24} + U_{34}$$

$$U = \frac{1}{4\pi\epsilon_0} \left[ \frac{-q^2}{a} + \frac{q^2}{\sqrt{2}a} - \frac{q^2}{a} - \frac{q^2}{a} + \frac{q^2}{\sqrt{2}a} - \frac{q^2}{a} \right]$$

$$U = \frac{1}{4\pi\epsilon_0} \left[ \frac{-4q^2}{a} + \frac{2q^2}{\sqrt{2}a} \right]$$

$$U = \frac{1}{4\pi\epsilon_0} \left[ \frac{-\sqrt{2}4q^2 + 2q^2}{\sqrt{2}a} \right] = \frac{-0.2q^2}{\epsilon_0 a}$$

The minus sign indicates that there is attractive force between the charges

In Example 5.13 assume that if all the charges are positive, prove that the work required to put the four charges together is

$$U = \frac{1}{4\pi\epsilon_0} \frac{5.41q^2}{\epsilon_0 a}$$



**Example 5.14**

In the rectangle shown in figure 5.17,  $q_1 = -5 \times 10^{-6} \text{C}$  and  $q_2 = 2 \times 10^{-6} \text{C}$  calculate the work required to move a charge  $q_3 = 3 \times 10^{-6} \text{C}$  from  $B$  to  $A$  along the diagonal of the rectangle.

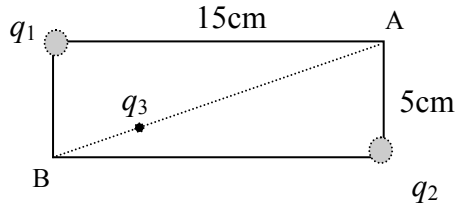

Figure 5.17



**Solution**

from the equation  $V_B - V_A = W_{AB} / q_0$

$$V_A = V_1 + V_2 \quad \& \quad V_B = V_1 + V_2$$

$$V_A = \frac{q}{4\pi\epsilon_0} \left[ \frac{-5 \times 10^{-6}}{0.15} + \frac{2 \times 10^{-6}}{0.05} \right] = 6 \times 10^4 \text{ V}$$

$$V_B = \frac{q}{4\pi\epsilon_0} \left[ \frac{-5 \times 10^{-6}}{0.05} + \frac{2 \times 10^{-6}}{0.15} \right] = -7.8 \times 10^4 \text{ V}$$

$$W_{BA} = (V_A - V_B) q_3$$

$$= (6 \times 10^4 + 7.8 \times 10^4) 3 \times 10^{-6} = 0.414 \text{ Joule}$$





**Example 5.15**

Two large parallel conducting plates are 10 cm apart and carry equal but opposite charges on their facing surfaces as shown in figure 5.18. An electron placed midway between the two plates experiences a force of  $1.6 \times 10^{-15}$  N.

What is the potential difference between the plates?



**Solution**

$$V_B - V_A = Ed$$

$$F = eE \Rightarrow E = F/e$$

$$V_B - V_A = 10000 \times 0.1 = 1000 \text{ volt}$$

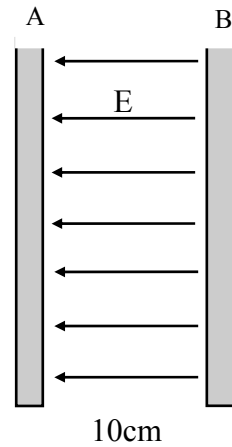

Figure 5.18



**5.10 Problems**

5.1) What potential difference is needed to stop an electron with an initial speed of  $4.2 \times 10^5 \text{ m/s}$ ?

5.2) An ion accelerated through a potential difference of 115V experiences an increase in potential energy of  $7.37 \times 10^{-17} \text{ J}$ . Calculate the charge on the ion.

5.3) How much energy is gained by a charge of  $75 \mu\text{C}$  moving through a potential difference of 90V?

5.4) An infinite charged sheet has a surface charge density  $\sigma$  of  $1.0 \times 10^{-7} \text{ C/m}^2$ . How far apart are the equipotential surfaces whose potentials differ by 5.0 V?

5.5) At what distance from a point charge of  $8 \mu\text{C}$  would the potential equal  $3.6 \times 10^4 \text{ V}$ ?

5.6) At a distance  $r$  away from a point charge  $q$ , the electrical potential is  $V=400 \text{ V}$  and the magnitude of the electric field is  $E=150 \text{ N/C}$ . Determine the value of  $q$  and  $r$ .

5.7) Calculate the value of the electric potential at point P due to the charge configuration shown in Figure 5.19. Use the values

$q_1=5 \mu\text{C}$ ,  $q_2=-10 \mu\text{C}$ ,  $a=0.4 \text{ m}$ , and  $b=0.5 \text{ m}$ .

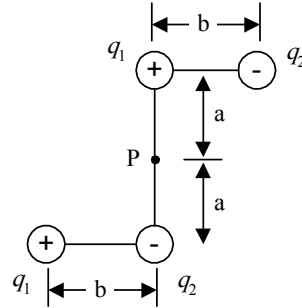

*Figure 5.19*

5.8) Two point charges are located as shown in Figure 5.20, where  $q_1=+4 \mu\text{C}$ ,  $q_2=-2 \mu\text{C}$ ,  $a=0.30 \text{ m}$ , and  $b=0.90 \text{ m}$ . Calculate the value of the electrical potential at points  $P_1$  and  $P_2$ . Which point is at the higher potential?

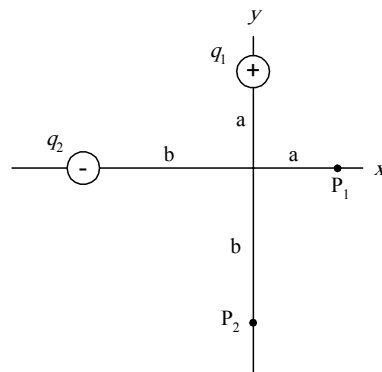

*Figure 5.20*

5.9) Consider a point charge with  $q=1.5 \times 10^{-6} \text{C}$ . What is the radius of an equipotential surface having a potential of 30V?

5.10) Two large parallel conducting plates are 10cm apart and carry equal and opposite charges on their facing surfaces. An electron placed midway between the two plates experiences a force of  $1.6 \times 10^{15} \text{N}$ . What is the potential difference between the plates?

5.11) A point charge has  $q=1.0 \times 10^{-6} \text{C}$ . Consider point A which is 2m distance and point B which is 1m distance as shown in the figure 5.21(a). (a) What is the potential difference  $V_A - V_B$ ? (b) Repeat if points A and B are located differently as shown in figure 5.21(b).

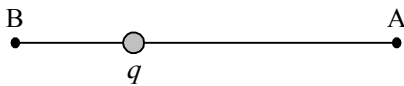

Figure 5.21(a)

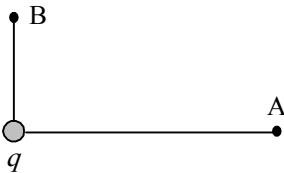

Figure 5.21(b)

5.12) In figure 5.22 prove that the work required to put four charges together on the corner of a square of radius  $a$  is given by  $(w = -0.21q^2 / \epsilon_0 a)$ .

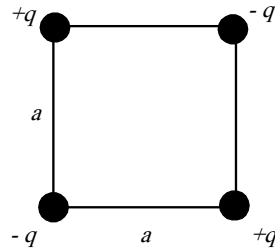

Figure 5.22

5.13) Two charges  $q = +2 \times 10^{-6} \text{C}$  are fixed in space a distance  $d = 2 \text{cm}$  apart, as shown in figure 5.23 (a) What is the electric potential at point C? (b) You bring a third charge  $q = 2.0 \times 10^{-6} \text{C}$  very slowly from infinity to C. How much work must you do? (c) What is the potential energy  $U$  of the configuration when the third charge is in place?

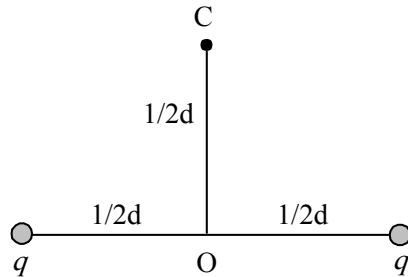

Figure 5.23

## *Electric Potential Difference*

---

- 5.14) Four equal point charges of charge  $q=+5\mu\text{C}$  are located at the corners of a 30cm by 40cm rectangle. Calculate the electric potential energy stored in this charge configuration.
- 5.15) Two point charges,  $Q_1=+5\text{nC}$  and  $Q_2=-3\text{nC}$ , are separated by 35cm. (a) What is the potential energy of the pair? What is the significance of the algebraic sign of your answer? (b) What is the electric potential at a point midway between the charges?
- 
-

# Multiple Choice Questions

## Part 1 Principles of Electrostatic

Coulomb's Law  
Electric Field  
Gauss's Law  
Electric Potential Difference



Attempt the following question after the completion of part 1

### Multiple choice question for part 1

---

[1] Two small beads having positive charges 3 and 1 are fixed on the opposite ends of a horizontal insulating rod, extending from the origin to the point  $x=d$ . As in Figure 1, a third small, charged bead is free to slide on the rod. At what position is the third bead in equilibrium?

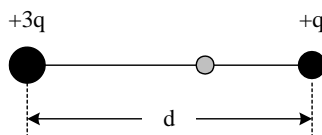

Figure 1

- a.  $x = 0.366d$
- b.  $x = 0.634d$
- c.  $x = 0.900d$
- d.  $x = 2.37d$

---

[2] Two identical conducting small spheres are placed with their centers 0.300m apart. One is given a charge of 12.0nC and the other one a charge of 18.0nC. (a) Find the electrostatic force exerted on one sphere by the other. (b) The spheres are connected by a conducting wire. After equilibrium has occurred, find the electrostatic force between the two.

- a. (a)  $2.16 \times 10^{-5}$  N attraction; (b) 0 N repulsion
- b. (a)  $6.47 \times 10^{-6}$  N repulsion; (b)  $2.70 \times 10^{-7}$  N attraction
- c. (a)  $2.16 \times 10^{-5}$  N attraction; (b)  $8.99 \times 10^{-7}$  N repulsion
- d. (a)  $6.47 \times 10^{-6}$  N attraction; (b)  $2.25 \times 10^{-5}$  N repulsion

---

[3] An electron is projected at an angle of  $40.0^\circ$  above the horizontal at a speed of  $5.20 \times 10^5$  m/s in a region where the electric field is  $E = 350$  j N/C. Neglect gravity and find (a) the time it takes the electron to return to its maximum height, (b) the maximum height it reaches and (c) its horizontal displacement when it reaches its maximum height.

- a. (a)  $1.09 \times 10^{-8}$  s; (b) 0.909 mm; (c) 2.17 m
- b. (a)  $1.69 \times 10^{-8}$  s; (b) 2.20 mm; (c) 4.40 m
- c. (a)  $1.09 \times 10^{-8}$  s; (b) 4.34 mm; (c) 0.909 m
- d. (a)  $1.30 \times 10^{-8}$  s; (b) 1.29 mm; (c) 2.17 m

---

[4] Two identical metal blocks resting on a frictionless horizontal surface are connected by a light metal spring for which the spring constant is  $k = 175$  N/m and the unscratched length is 0.350 m as in Figure 2a.

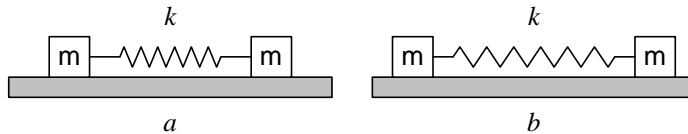

Figure 2

A charge  $Q$  is slowly placed on the system causing the spring to stretch to an equilibrium length of 0.460 m as in Figure 2b. Determine the value of  $Q$ , assuming that all the charge resides in the blocks and that the blocks can be treated as point charges.

- a.  $64.8 \mu\text{C}$
- b.  $32.4 \mu\text{C}$
- c.  $85.1 \mu\text{C}$
- d.  $42.6 \mu\text{C}$

[5] A small plastic ball 1.00 g in mass is suspended by a 24.0 cm long string in a uniform electric field as shown in Figure P23.52.

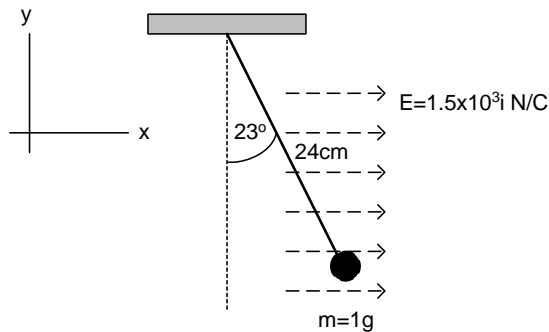

Figure 3

If the ball is in equilibrium when the string makes a  $23.0^\circ$  angle with the vertical, what is the net charge on the ball?

- a.  $36.1 \mu\text{C}$
- b.  $15.4 \mu\text{C}$
- c.  $6.53 \mu\text{C}$
- d.  $2.77 \mu\text{C}$

[6] An object having a net charge of  $24.0 \mu\text{C}$  is placed in a uniform electric field of  $6 \times 10^4 \text{ N/C}$  directed vertically. What is the mass of the object if it "floats" in the field?

**Multiple choice question for part 1**

---

- a. 0.386 g
- b. 0.669 g
- c. 2.59 g
- d. 1.49 g

---

[7] Four identical point charges ( $q = +14.0 \mu\text{C}$ ) are located on the corners of a rectangle as shown in Figure 4.

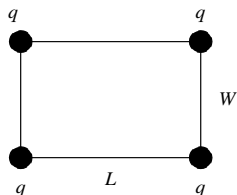

**Figure 4**

The dimensions of the rectangle are  $L = 55.0 \text{ cm}$  and  $W = 13.0 \text{ cm}$ . Calculate the magnitude and direction of the net electric force exerted on the charge at the lower left corner by the other three charges. (Call the lower left corner of the rectangle the origin.)

- a. 106 mN @  $264^\circ$
- b. 7.58 mN @  $13.3^\circ$
- c. 7.58 mN @  $84.0^\circ$
- d. 106 mN @  $193^\circ$

---

[8] An electron and proton are each placed at rest in an electric field of  $720 \text{ N/C}$ . Calculate the speed of each particle  $44.0 \text{ ns}$  after being released.

- a.  $v_e = 1.27 \times 10^6 \text{ m/S}$ ,  $v_p = 6.90 \times 10^3 \text{ m/s}$
  - b.  $v_e = 5.56 \times 10^6 \text{ m/S}$ ,  $v_p = 3.04 \times 10^3 \text{ m/s}$
  - c.  $v_e = 1.27 \times 10^{14} \text{ m/S}$ ,  $v_p = 6.90 \times 10^{10} \text{ m/s}$
  - d.  $v_e = 3.04 \times 10^3 \text{ m/S}$ ,  $v_p = 5.56 \times 10^6 \text{ m/s}$
- 

[9] Three point charges are arranged as shown in Figure 5.



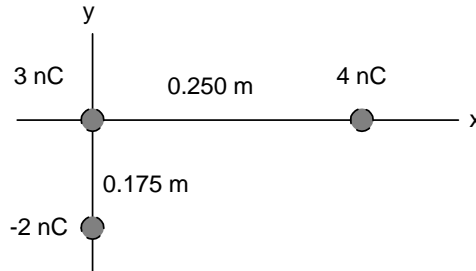

Figure 5

(a) Find the vector electric field that the 4.00 nC and -2.00 nC charges together create at the origin. (b) Find the vector force on the 3.00 nC charge.

- |   |  |
|---|--|
| a. (a) $(0.144\mathbf{i} - 0.103\mathbf{j})$ kN/C;  | (b) $(0.432\mathbf{i} - 0.308\mathbf{j})$ $\mu$ N  |
| b. (a) $(-0.575\mathbf{i} - 0.587\mathbf{j})$ kN/C; | (b) $(-1.73\mathbf{i} - 1.76\mathbf{j})$ $\mu$ N   |
| c. (a) $(-0.144\mathbf{i} - 0.103\mathbf{j})$ kN/C; | (b) $(-0.432\mathbf{i} - 0.308\mathbf{j})$ $\mu$ N |
| d. (a) $(-0.575\mathbf{i} + 0.587\mathbf{j})$ kN/C; | (b) $(-1.73\mathbf{i} + 1.76\mathbf{j})$ $\mu$ N   |

[10] Two  $1.00\ \mu\text{C}$  point charges are located on the x axis. One is at  $x = 0.60$  m, and the other is at  $x = -0.60$  m. (a) Determine the electric field on the y axis at  $x = 0.90$  m. (b) Calculate the electric force on a  $-5.00\ \mu\text{C}$  charge placed on the y axis at  $y = 0.90$  m.

- |   |  |
|---|--|
| a. (a) $(8.52 \times 10^3\mathbf{i} + 1.28 \times 10^4\mathbf{j})$ N/C; | (b) $(-4.62 \times 10^{-2}\mathbf{i} - 6.39 \times 10^{-2}\mathbf{j})$ N |
| b. (a) $8.52 \times 10^3\mathbf{j}$ N/C;                                | (b) $-4.26 \times 10^{-2}\mathbf{j}$ N                                   |
| c. (a) $1.28 \times 10^4\mathbf{j}$ N/C;                                | (b) $-6.39 \times 10^{-2}\mathbf{j}$ N                                   |
| d. (a) $-7.68 \times 10^3\mathbf{j}$ N/C;                               | (b) $3.84 \times 10^{-2}\mathbf{j}$ N                                    |

[11] A  $14.0\ \mu\text{C}$  charge located at the origin of a cartesian coordinate system is surrounded by a nonconducting hollow sphere of radius 6.00 cm. A drill with a radius of 0.800 mm is aligned along the z-axis, and a hole is drilled in the sphere. Calculate the electric flux through the hole.

- $176\ \text{Nm}^2/\text{C}$
- $4.22\ \text{Nm}^2/\text{C}$
- $0\ \text{Nm}^2/\text{C}$
- $70.3\ \text{Nm}^2/\text{C}$

[12] An electric field of intensity  $2.50\ \text{kN/C}$  is applied along the x-axis. Calculate the electric flux through a rectangular plane  $0.450$  m wide and

### Multiple choice question for part 1

---

0.800 m long if (a) the plane is parallel to the  $yz$  plane; (b) the plane is parallel to the  $xy$  plane; (c) the plane contains the  $y$ -axis and its normal makes an angle of  $30.0^\circ$  with the  $x$ -axis.

- a. (a)  $900 \text{ Nm}^2/\text{C}$ ; (b)  $0 \text{ Nm}^2/\text{C}$ ; (c)  $779 \text{ Nm}^2/\text{C}$
- b. (a)  $0 \text{ Nm}^2/\text{C}$ ; (b)  $900 \text{ Nm}^2/\text{C}$ ; (c)  $779 \text{ Nm}^2/\text{C}$
- c. (a)  $0 \text{ Nm}^2/\text{C}$ ; (b)  $900 \text{ Nm}^2/\text{C}$ ; (c)  $450 \text{ Nm}^2/\text{C}$
- d. (a)  $900 \text{ Nm}^2/\text{C}$ ; (b)  $0 \text{ Nm}^2/\text{C}$ ; (c)  $450 \text{ Nm}^2/\text{C}$

---

[13] A conducting spherical shell of radius 13.0 cm carries a net charge of  $-7.40 \mu\text{C}$  uniformly distributed on its surface. Find the electric field at points (a) just outside the shell and (b) inside the shell.

- a. (a)  $(-7.88 \text{ mN/C})r$ ; (b)  $(-7.88 \text{ mN/C})r$
- b. (a)  $(7.88 \text{ mN/C})r$ ; (b)  $(0 \text{ mN/C})r$
- c. (a)  $(-3.94 \text{ mN/C})r$ ; (b)  $(0 \text{ mN/C})r$
- d. (a)  $(3.94 \text{ mN/C})r$ ; (b)  $(3.94 \text{ mN/C})r$

---

[14] A point charge of  $0.0562 \mu\text{C}$  is inside a pyramid. Determine the total electric flux through the surface of the pyramid.

- a.  $1.27 \times 10^3 \text{ Nm}^2/\text{C}^2$
- b.  $6.35 \times 10^3 \text{ Nm}^2/\text{C}^2$
- c.  $0 \text{ Nm}^2/\text{C}^2$
- d.  $3.18 \times 10^4 \text{ Nm}^2/\text{C}^2$

---

[15] A large flat sheet of charge has a charge per unit area of  $7.00 \mu\text{C}/\text{m}^2$ . Find the electric field intensity just above the surface of the sheet, measured from its midpoint.

- a.  $7.91 \times 10^5 \text{ N/C}$  up
- b.  $1.98 \times 10^5 \text{ N/C}$  up
- c.  $3.95 \times 10^5 \text{ N/C}$  up
- d.  $1.58 \times 10^6 \text{ N/C}$  up

---

[16] The electric field on the surface of an irregularly shaped conductor varies from  $60.0 \text{ kN/C}$  to  $24.0 \text{ kN/C}$ . Calculate the local surface charge

density at the point on the surface where the radius of curvature of the surface is (a) greatest and (b) smallest.

- a.  $0.531 \mu\text{C}/\text{m}^2$ ; (b)  $0.212, \mu\text{C}/\text{m}^2$
- b.  $1.06, \mu\text{C}/\text{m}^2$ ; (b)  $0.425 \mu\text{C}/\text{m}^2$
- c.  $0.425, \mu\text{C}/\text{m}^2$ ; (b)  $1.06\mu\text{C}/\text{m}^2$
- d.  $0.212 \mu\text{C}/\text{m}^2$ ; (b)  $0.531 \mu\text{C}/\text{m}^2$

---

[17] A square plate of copper with 50.0 cm sides has no net charge and is placed in a region of uniform electric field of 80.0 kN/C directed perpendicular to the plate. Find (a) the charge density of each face of the plate and (b) the total charge on each face.

- a. (a)  $\sigma = \pm 0.708 \mu\text{C}/\text{m}^2$ ; (b)  $Q = \pm 0.0885 \mu\text{C}$
- b. (a)  $\sigma = \pm 1.42 \mu\text{C}/\text{m}^2$ ; (b)  $Q = \pm 0.354 \mu\text{C}$
- c. (a)  $\sigma = \pm 0.708 \mu\text{C}/\text{m}^2$ ; (b)  $Q = \pm 0.177 \mu\text{C}$
- d. (a)  $\sigma = \pm 1.42 \mu\text{C}/\text{m}^2$ ; (b)  $Q = \pm 0.177 \mu\text{C}$

---

[18] The following charges are located inside a submarine:  $5.00\mu\text{C}$ ,  $-9.00\mu\text{C}$ ,  $27.0\mu\text{C}$  and  $-84.0\mu\text{C}$ . (a) Calculate the net electric flux through the submarine. (b) Is the number of electric field lines leaving the submarine greater than, equal to, or less than the number entering it?

- a. (a)  $1.41 \times 10^7 \text{ Nm}^2/\text{C}$ ; (b) greater than
- b. (a)  $-6.89 \times 10^6 \text{ Nm}^2/\text{C}$ ; (b) less than
- c. (a)  $-6.89 \times 10^6 \text{ Nm}^2/\text{C}$ ; (b) equal to
- d. (a)  $1.41 \times 10^7 \text{ Nm}^2/\text{C}$ ; (b) equal to

---

[19] A solid sphere of radius 40.0 cm has a total positive charge of  $26.0\mu\text{C}$  uniformly distributed throughout its volume. Calculate the magnitude of the electric field at 90.0 cm.

- a.  $(2.89 \times 10^5 \text{ N/C})r$
  - b.  $(3.29 \times 10^6 \text{ N/C})r$
  - c.  $0 \text{ N/C}$
  - d.  $(1.46 \times 10^6 \text{ N/C})r$
-

*Multiple choice question for part 1*

---

[20] A charge of  $190 \mu\text{C}$  is at the center of a cube of side  $85.0 \text{ cm}$  long. (a) Find the total flux through each face of the cube. (b) Find the flux through the whole surface of the cube.

- a. (a)  $3.58 \times 10^6 \text{ Nm}^2/\text{C}$ ; (b)  $2.15 \times 10^7 \text{ Nm}^2/\text{C}$
- b. (a)  $4.10 \times 10^7 \text{ Nm}^2/\text{C}$ ; (b)  $4.10 \times 10^7 \text{ Nm}^2/\text{C}$
- c. (a)  $1.29 \times 10^8 \text{ Nm}^2/\text{C}$ ; (b)  $2.15 \times 10^7 \text{ Nm}^2/\text{C}$
- d. (a)  $6.83 \times 10^6 \text{ Nm}^2/\text{C}$ ; (b)  $4.10 \times 10^7 \text{ Nm}^2/\text{C}$

---

[21] A  $30.0 \text{ cm}$  diameter loop is rotated in a uniform electric field until the position of maximum electric flux is found. The flux in this position is found to be  $3.20 \times 10^5 \text{ Nm}^2/\text{C}$ . What is the electric field strength?

- a.  $3.40 \times 10^5 \text{ N/C}$
- b.  $4.53 \times 10^6 \text{ N/C}$
- c.  $1.13 \times 10^6 \text{ N/C}$
- d.  $1.70 \times 10^5 \text{ N/C}$

---

[22] Consider a thin spherical shell of radius  $22.0 \text{ cm}$  with a total charge of  $34.0 \mu\text{C}$  distributed uniformly on its surface. Find the magnitude of the electric field (a)  $15.0 \text{ cm}$  and (b)  $30.0 \text{ cm}$  from the center of the charge distribution.

- a. (a)  $6.32 \times 10^6 \text{ N/C}$ ; (b)  $3.40 \times 10^6 \text{ N/C}$
- b. (a)  $0 \text{ N/C}$ ; (b)  $6.32 \times 10^6 \text{ N/C}$
- c. (a)  $1.36 \times 10^7 \text{ N/C}$ ; (b)  $3.40 \times 10^6 \text{ N/C}$
- d. (a)  $0 \text{ N/C}$ ; (b)  $3.40 \times 10^6 \text{ N/C}$

---

[23] A long, straight metal rod has a radius of  $5.00 \text{ cm}$  and a charge per unit length of  $30.0 \text{ nC/m}$ . Find the electric field  $100.0 \text{ cm}$  from the axis of the rod, where distances are measured perpendicular to the rod.

- a.  $(1.08 \times 10^4 \text{ N/C})r$
  - b.  $(2.70 \times 10^2 \text{ N/C})r$
  - c.  $(5.39 \times 10^2 \text{ N/C})r$
  - d.  $(0 \text{ N/C})r$
-

[24] A solid conducting sphere of radius 2.00 cm has a charge of  $8.00 \mu\text{C}$ . A conducting spherical shell of inner radius 4.00 cm and outer radius 5.00 cm is concentric with the solid sphere and has a charge of  $-4.00 \mu\text{C}$ . Find the electric field at  $r = 7.00 \text{ cm}$  from the center of this charge configuration.

- $(2.20 \times 10^7 \text{ N/C})r$
- $(4.32 \times 10^7 \text{ N/C})r$
- $(7.34 \times 10^6 \text{ N/C})r$
- $(1.44 \times 10^7 \text{ N/C})r$

[25] The electric field everywhere on the surface of a thin spherical shell of radius 0.650 m is measured to be equal to  $790 \text{ N/C}$  and points radially toward the center of the sphere. (a) What is the net charge within the sphere's surface? (b) What can you conclude about the nature and distribution of the charge inside the spherical shell?

- (a)  $3.71 \times 10^{-8} \text{ C}$ ; (b) The charge is negative, its distribution is spherically symmetric.
- (a)  $3.71 \times 10^{-8} \text{ C}$ ; (b) The charge is positive, its distribution is uncertain.
- (a)  $1.93 \times 10^{-4} \text{ C}$ ; (b) The charge is positive, its distribution is spherically symmetric.
- (a)  $1.93 \times 10^{-4} \text{ C}$ ; (b) The charge is negative, its distribution is uncertain.

[26] Four identical point charges ( $q = +16.0 \mu\text{C}$ ) are located on the corners of a rectangle, as shown in Figure 6.

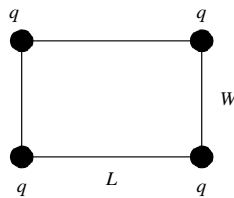

Figure 6

The dimensions of the rectangle are  $L = 70.0 \text{ cm}$  and  $W = 30.0 \text{ cm}$ . Calculate the electric potential energy of the charge at the lower left corner due to the other three charges.

- 14.9 J

*Multiple choice question for part 1*

---

- b. 7.94 J
- c. 14.0 J
- d. 34.2 J

---

[27] The three charges in Figure 7 are at the vertices of an isosceles triangle.

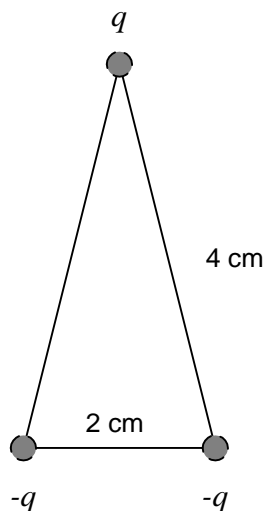

*Figure 7*

Calculate the electric potential at the midpoint of the base, taking  $q=7.00 \mu\text{C}$ .

- a. -14.2 mV
- b. 11.0 mV
- c. 14.2 mV
- d. -11.0mV

---

[28] An insulating rod having a linear charge density  $= 40.0 \mu\text{C}/\text{m}$  and linear mass density  $0.100 \text{ kg}/\text{m}$  is released from rest in a uniform electric field  $E=100 \text{ V}/\text{m}$  directed perpendicular to the rod (Fig. 8).

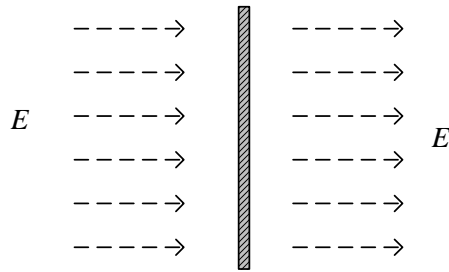

Figure 8

(a) Determine the speed of the rod after it has traveled 2.00 m. (b) How does your answer to part (a) change if the electric field is not perpendicular to the rod?

- (a) 0.200 m/s; (b) decreases
- (a) 0.400 m/s; (b) the same
- (a) 0.400 m/s; (b) decreases
- (a) 0.200 m/s; (b) increases

[29] A spherical conductor has a radius of 14.0 cm and a charge of  $26.0\mu\text{C}$ . Calculate the electric field and the electric potential at  $r = 50.0$  cm from the center.

- $9.35 \times 10^5$  N/C, 1.67 mV
- $1.19 \times 10^7$  N/C, 0.468 mV
- $9.35 \times 10^5$  N/C, 0.468 mV
- $1.19 \times 10^7$  N/C, 1.67 mV

[30] How many electrons should be removed from an initially unchanged spherical conductor of radius 0.200 m to produce a potential of 6.50 kV at the surface?

- $1.81 \times 10^{11}$
- $2.38 \times 10^{15}$
- $9.04 \times 10^{11}$
- $1.06 \times 10^{15}$

[31] An ion accelerated through a potential difference of 125 V experiences an increase in kinetic energy of  $9.37 \times 10^{-17}$  J. Calculate the charge on the ion.

**Multiple choice question for part 1**

---

- a.  $1.33 \times 10^{18} \text{ C}$
- b.  $7.50 \times 10^{-19} \text{ C}$
- c.  $1.17 \times 10^{-14} \text{ C}$
- d.  $1.60 \times 10^{-19} \text{ C}$

---

[32] How much work is done (by a battery, generator, or some other source of electrical energy) in moving Avogadro's number of electrons from an initial point where the electric potential is 9.00 V to a point where the potential is -5.00 V? (The potential in each case is measured relative to a common reference point.)

- a. 0.482 MJ
- b. 0.385 MJ
- c. 1.35 MJ
- d. 0.867 MJ

---

[33] At a certain distance from a point charge, the magnitude of the electric field is 600 V/m and the electric potential is -4.00 kV. (a) What is the distance to the charge? (b) What is the magnitude of the charge?

- a. (a) 0.150 m; (b) 0.445  $\mu\text{C}$
- b. (a) 0.150 m; (b) -1.50  $\mu\text{C}$
- c. (a) 6.67 m; (b) 2.97  $\mu\text{C}$
- d. (a) 6.67 m; (b) -2.97  $\mu\text{C}$

---

[34] An electron moving parallel to the x-axis has an initial speed of  $3.70 \times 10^6 \text{ m/s}$  at the origin. Its speed is reduced to  $1.40 \times 10^5 \text{ m/s}$  at the point  $x = 2.00 \text{ cm}$ . Calculate the potential difference between the origin and that point. Which point is at the higher potential?

- a. -38.9 V, the origin
- b. 19.5 V, x
- c. 38.9 V, x
- d. -19.5 V, the origin

---

ddddddddddddddddddd

**Solution of the multiple choice questions**



Q. No.	Answer	Q. No.	Answer
1	b	18	b
2	c	19	a
3	a	20	a
4	d	21	b
5	d	22	d
6	d	23	c
7	a	24	c
8	b	25	a
9	b	26	c
10	c	27	d
11	d	28	b
12	a	29	c
13	c	30	c
14	b	31	b
15	c	32	c
16	d	33	d
17	c	34	a

đđđđđđđđđđđđđđđđđđđđđđđđđđđđđđđđ

**LECTURES IN GENERAL PHYSICS**

# *Electrostatic*

*Principles and Applications*

Dr. Hazem Falah Sakeek

Al-Azhar University - Gaza

*Part Two*

## Part 2

# Applications of Electrostatic

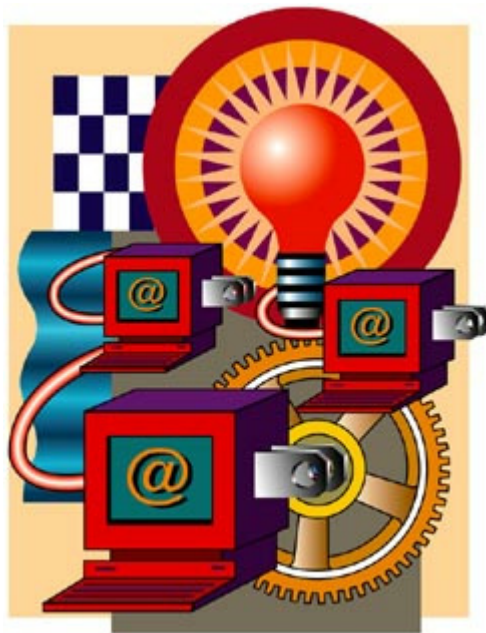

## Chapter 6

# Capacitors and Capacitance

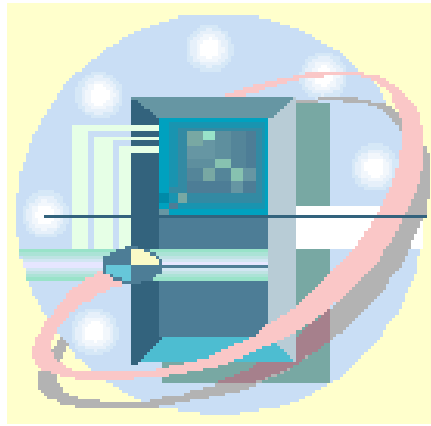

المكثف الكهربى

والسعة الكهربية

# Capacitors and Capacitance

## 6.1 Capacitor

## 6.2 Definition of capacitance

## 6.3 Calculation of capacitance

### 6.3.1 Parallel plate capacitor

### 6.3.2 Cylindrical capacitor

### 6.3.3 Spherical capacitor

## 6.4 Combination of capacitors

### 6.4.1 Capacitors in parallel

### 6.4.2 Capacitors in series

## 4.5 Energy stored in a charged capacitor (in electric field)

## 6.6 Capacitor with dielectric

## 6.7 problems

# Capacitors and Capacitance

## المكثف الكهربى والسعة الكهربية



يعتبر هذا الفصل تطبيقاً على المفاهيم الأساسية للكهربية الساكنة، حيث سنركز على التعرف على خصائص المكثفات Capacitors وهي من الأجهزة الكهربية التي لا تخلو منها أية دائرة كهربية. ويعد المكثف بمثابة مخزن للطاقة الكهربية. والمكثف عبارة عن موصلين يفصل بينهما مادة عازلة.



### 6.1 Capacitor

A capacitor consists of two conductors separated by an insulator Figure 6.1. The capacitance of the capacitor depends on the geometry of the conductors and on the material separating the charged conductors, called dielectric that is an insulating material. The two conductors carry equal and opposite charge  $+q$  and  $-q$ .

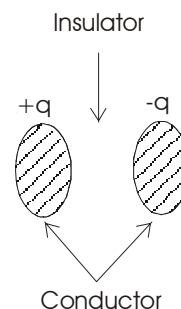

Figure 6.1

### 6.2 Definition of capacitance

The capacitance  $C$  of a capacitor is defined as the ratio of the magnitude of the charge on either conductor to the magnitude of the potential difference between them as shown in Figure 6.2.

$$C = \frac{q}{V} \quad (6.1)$$

The capacitance  $C$  has a unit of  $C/v$ , which is called *farad*  $F$

$$F = C/v$$

The farad is very big unit and hence we use submultiples of farad

$$1\mu\text{F} = 10^{-6}\text{F}$$

$$1\text{nF} = 10^{-9}\text{F}$$

$$1\text{pF} = 10^{-12}\text{F}$$

The capacitor in the circuit is represented by the symbol shown in Figure 6.3.

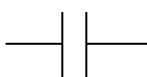

Figure 6.3

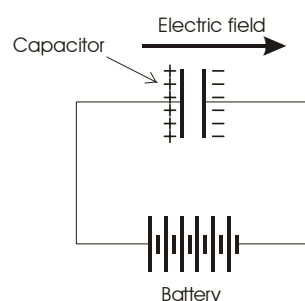

Figure 6.2

### 6.3 Calculation of capacitance

The most common type of capacitors are:-

- Parallel-plate capacitor
- Cylindrical capacitor
- Spherical capacitor

We are going to calculate the capacitance of parallel plate capacitor using the information we learned in the previous chapters and make use of the equation (6.1).

#### 6.3.1 Parallel plate capacitor

Two parallel plates of equal area  $A$  are separated by distance  $d$  as shown in figure 6.4 below. One plate charged with  $+q$ , the other  $-q$ .

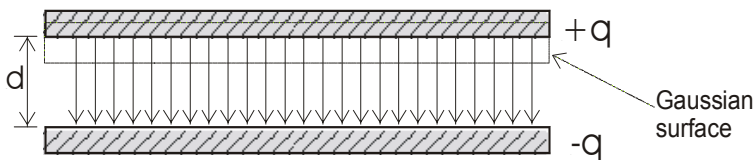

Figure 6.4

The capacitance is given by  $C = \frac{q}{V}$

First we need to evaluate the electric field  $E$  to work out the potential  $V$ .

Using Gauss law to find  $E$ , the charge per unit area on either plate is

$$\sigma = q/A. \quad (6.2)$$

$$\therefore E = \frac{\sigma}{\epsilon_0} = \frac{q}{\epsilon_0 A} \quad (6.3), (4.9)$$

The potential difference between the plates is equal to  $Ed$ , therefore

$$V = Ed = \frac{qd}{\epsilon_0 A} \quad (6.4)$$

The capacitance is given by



## Capacitors and capacitance

---

$$C = \frac{q}{V} = \frac{q}{qd/\epsilon_o A} \quad (6.5)$$

$$\therefore C = \frac{\epsilon_o A}{d} \quad (6.6)$$

Notice that the capacitance of the parallel plates capacitor is depends on the geometrical dimensions of the capacitor.

The capacitance is proportional to the area of the plates and inversely proportional to distance between the plates.

(6.6)



### Example 6.1

An air-filled capacitor consists of two plates, each with an area of  $7.6\text{cm}^2$ , separated by a distance of  $1.8\text{mm}$ . If a  $20\text{V}$  potential difference is applied to these plates, calculate,

- the electric field between the plates,
- the surface charge density,
- the capacitance, and
- the charge on each plate.



### Solution

$$(a) E = \frac{V}{d} = \frac{20}{1.8 \times 10^{-3}} = 1.11 \times 10^4 \text{ V/m}$$

$$(b) \sigma = \epsilon_o E = (8.85 \times 10^{-12})(1.11 \times 10^4) = 9.83 \times 10^{-8} \text{ C/m}^2$$

$$(c) C = \frac{\epsilon_o A}{d} = \frac{(8.85 \times 10^{-12})(7.6 \times 10^{-4})}{1.8 \times 10^{-3}} = 3.74 \times 10^{-12} \text{ F}$$

$$(d) q = CV = (3.74 \times 10^{-12})(20) = 7.48 \times 10^{-11} \text{ C}$$

### 6.3.2 Cylindrical capacitor

In the same way we can calculate the capacitance of cylindrical capacitor, the result is as follow

$$C = \frac{2\pi\epsilon_0 l}{\ln(b/a)} \quad (6.7)$$

Where  $l$  is the length of the cylinder,  $a$  is the radius of the inside cylinder, and  $b$  the radius of the outer shell cylinder.

### 6.3.3 Spherical Capacitor

In the same way we can calculate the capacitance of spherical capacitor, the result is as follow

$$C = \frac{4\pi\epsilon_0 ab}{b - a} \quad (6.8)$$

Where  $a$  is the radius of the inside sphere, and  $b$  is the radius of the outer shell sphere.



#### **Example 6.2**

An air-filled spherical capacitor is constructed with inner and outer shell radii of 7 and 14cm, respectively. Calculate,

- (a) The capacitance of the device,
- (b) What potential difference between the spheres will result in a charge of  $4\mu\text{C}$  on each conductor?



#### **Solution**

$$(a) C = \frac{4\pi\epsilon_0 ab}{b - a} = \frac{(4\pi \times 8.85 \times 10^{-12})(0.07)(0.14)}{(0.14 - 0.07)} = 1.56 \times 10^{-11} F$$

$$(b) V = \frac{q}{C} = \frac{4 \times 10^{-6}}{1.56 \times 10^{-11}} = 2.56 \times 10^5 V$$

## 6.4 Combination of capacitors

Some times the electric circuit consist of more than two capacitors, which are, connected either in parallel or in series the equivalent capacitance is evaluated as follow

### 6.4.1 Capacitors in parallel:

In parallel connection the capacitors are connected as shown in figure 6.5 below where the above plates are connected together with the positive terminal of the battery, and the bottom plates are connected to the negative terminal of the battery.

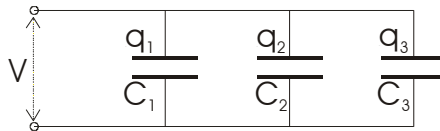

Figure 6.5

In this case the potential different across each capacitor is equal to the voltage of the battery  $V$

$$i.e. V=V_1=V_2=V_3$$

The charge on each capacitor is

$$q_1 = C_1V_1; \quad q_2 = C_2V_2; \quad q_3 = C_3V_3$$

The total charge is

$$q = q_1 + q_2 + q_3$$
$$q = (C_1 + C_2 + C_3)V$$

$$\therefore C = \frac{q}{V}$$

The Equivalent capacitance is

$$C = C_1 + C_2 + C_3$$

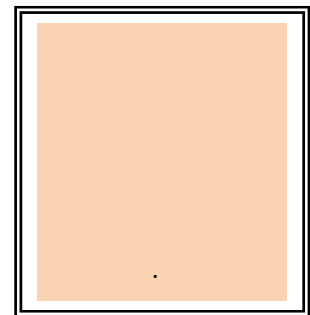

(6.9)

**6.4.2 Capacitors in series:**

In series connection the capacitors are connected as shown in figure 6.6 below where the above plates are connected together with the positive

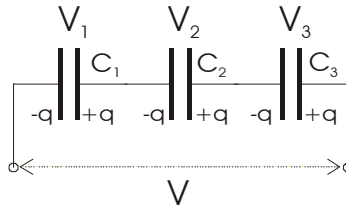

Figure 6.6

In this case the magnitude of the charge must be the same on each plate with opposite sign

$$i.e. q=q_1=q_2=q_3$$

The potential across each capacitor is

$$V_1 = q / C_1; \quad V_2 = q / C_2; \quad V_3 = q / C_3$$

The total potential V is equal the sum of the potential across each capacitor

$$V = V_1 + V_2 + V_3$$

$$V = q \left( \frac{1}{C_1} + \frac{1}{C_2} + \frac{1}{C_3} \right)$$

$$C = \frac{q}{V} = \frac{1}{\frac{1}{C_1} + \frac{1}{C_2} + \frac{1}{C_3}}$$

The Equivalent capacitance is

$$\frac{1}{C} = \frac{1}{C_1} + \frac{1}{C_2} + \frac{1}{C_3}$$

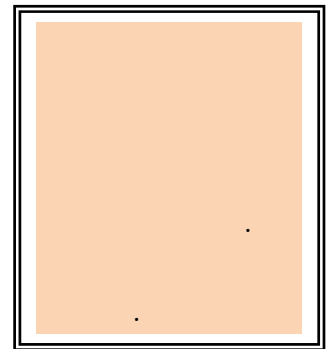

(6.10)



**Example 6.3**

Find the equivalent capacitance between points a and b for the group of capacitors shown in figure 6.7 .  $C_1=1\mu\text{F}$ ,  $C_2=2\mu\text{F}$ ,  $C_3=3\mu\text{F}$ ,  $C_4=4\mu\text{F}$ ,  $C_5=5\mu\text{F}$ , and  $C_6=6\mu\text{F}$ .

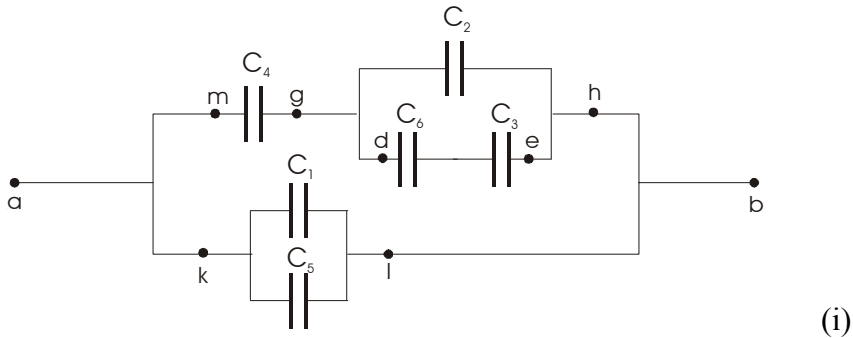

Figure 6.7



**Solution**

First the capacitor  $C_3$  and  $C_6$  are connected in series so that the equivalent capacitance  $C_{de}$  is

$$\frac{1}{C_{de}} = \frac{1}{6} + \frac{1}{3}; \Rightarrow C_{de} = 2\mu\text{F}$$

Second  $C_1$  and  $C_5$  are connected in parallel

$$C_{ki}=1+5=6\mu\text{F}$$

The circuit become as shown below

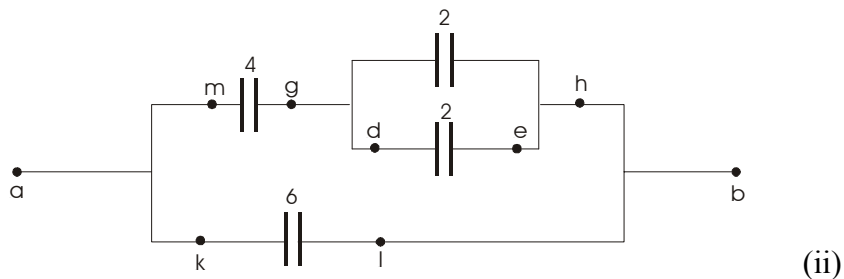

Continue with the same way to reduce the circuit for the capacitor  $C_2$  and  $C_{de}$  to get  $C_{gh}=4\mu\text{F}$

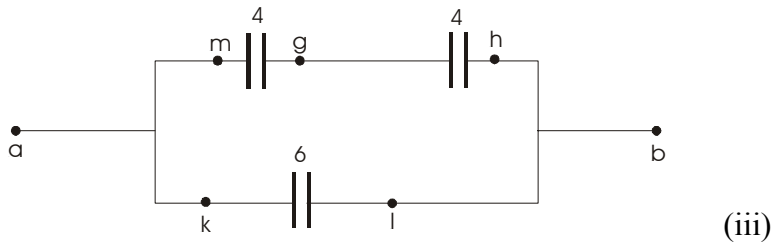

Capacitors  $C_{mg}$  and  $C_{gh}$  are connected in series the result is  $C_{mh}=2\mu\text{F}$ , The circuit become as shown below

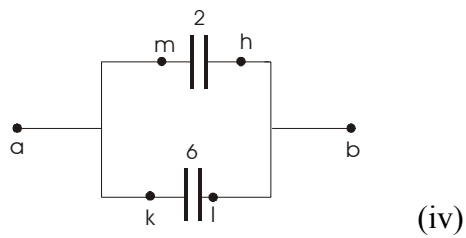

Capacitors  $C_{mh}$  and  $C_{kl}$  are connected in parallel the result is

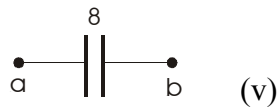

$$C_{eq}=8\mu\text{F}.$$



### Example 6.4

In the above example 6.3 determine the potential difference across each capacitor and the charge on each capacitor if the total charge on all the six capacitors is  $384\mu\text{C}$ .



### Solution

First consider the equivalent capacitor  $C_{\text{eq}}$  to find the potential between points a and b ( $V_{\text{ab}}$ )

$$V_{\text{ab}} = \frac{Q_{\text{ab}}}{C_{\text{ab}}} = \frac{384}{8} = 48\text{V}$$

Second notice that the potential  $V_{\text{kl}}=V_{\text{ab}}$  since the two capacitors between  $k$  and  $l$  are in parallel, the potential across the capacitors  $C_1$  and  $C_5 = 48\text{V}$ .

$$V_1=48\text{V and } Q_1=C_1 V_1=48\mu\text{C}$$

### And for $C_5$

$$V_5=48\text{V and } Q_5=C_5 V_5=240\mu\text{C}$$

For the circuit (iv) notice that  $V_{\text{mh}}=V_{\text{ab}}=48\text{V}$ , and

$$Q_{\text{mh}}=C_{\text{mh}} V_{\text{mh}}=2 \times 48=96\mu\text{C}$$

Since the two capacitors shown in the circuit (iii) between points  $m$  and  $h$  are in series, each will have the same charge as that of the equivalent capacitor, *i.e.*

$$Q_{\text{mh}}=Q_{\text{gh}}=Q_{\text{mh}}=96\mu\text{C}$$

$$V_{\text{mg}} = \frac{Q_{\text{mg}}}{C_{\text{mg}}} = \frac{96}{4} = 24\text{V}$$

$$V_{\text{gh}} = \frac{Q_{\text{gh}}}{C_{\text{gh}}} = \frac{96}{4} = 24\text{V}$$

**Therefore for  $C_4$ ,  $V_4=24$  and  $Q_4=96\mu\text{C}$**

In the circuit (ii) the two capacitor between points  $g$  and  $h$  are in parallel so the potential difference across each is  $24\text{V}$ .

Therefore for  $C_2$ ,  $V_2=24\text{V}$  and  $Q_2=C_2V_2=48\mu\text{C}$

Also in circuit (ii) the potential difference

$$V_{de}=V_{gh}=24\text{V}$$

And

$$Q_{de}=C_{de}V_{de}=2\times 24=48\mu\text{C}$$

The two capacitors shown in circuit (i) between points  $d$  and  $a$  are in series, and therefore the charge on each is equal to  $Q_{de}$ .

Therefore for  $C_6$ ,  $Q_6=48\mu\text{C}$

$$V_6 = \frac{Q_6}{C_6} = 8\text{V}$$

For  $C_3$ ,  $Q_3=48\mu\text{C}$  and  $V_3=Q_3/C_3=16\text{V}$

The results can be summarized as follow:

Capacitor	Potential Difference (V)	Charge ( $\mu\text{C}$ )
$C_1$	48	48
$C_2$	24	48
$C_3$	16	48
$C_4$	24	96
$C_5$	48	240
$C_6$	8	48
$C_{eq}$	48	384



### 4.5 Energy stored in a charged capacitor (in electric field)

If the capacitor is connected to a power supply such as battery, charge will be transferred from the battery to the plates of the capacitor. This is a charging process of the capacitor which mean that the battery perform a work to store energy between the plates of the capacitor.

Consider uncharged capacitor is connected to a battery as shown in figure 6.8, at start the potential across the plates is zero and the charge is zero as well.

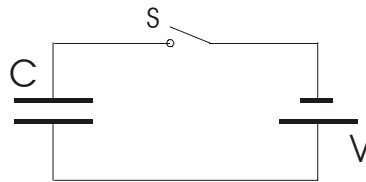

Figure 6.8

If the switch  $S$  is closed then the charging process will start and the potential across the capacitor will rise to reach the value equal the potential of the battery  $V$  in time  $t$  (called charging time).

S

Suppose that at a time  $t$  a charge  $q(t)$  has been transferred from the battery to capacitor. The potential difference  $V(t)$  across the capacitor will be  $q(t)/C$ . For the battery to transferred another amount of charge  $dq$  it will perform a work  $dW$

$$dW = Vdq = \frac{q}{C} dq \quad (6.11)$$

The total work required to put a total charge  $Q$  on the capacitor is

$$W = \int dW = \int_0^Q \frac{q}{C} dq = \frac{Q^2}{2C} \quad (6.12)$$

Using the equation  $q=CV$

$$W = U = \frac{Q^2}{2C} \quad (6.13)$$

$$U = \frac{1}{2} \frac{Q^2}{C} = \frac{1}{2} QV = \frac{1}{2} CV^2 \quad (6.14)$$

The energy per unit volume  $u$  (energy density) in parallel plate capacitor is the total energy stored  $U$  divided by the volume between the plates  $Ad$

$$u = \frac{U}{Ad} = \frac{\frac{1}{2} CV^2}{Ad} \quad (6.15)$$

For parallel plate capacitor  $C = \frac{\epsilon_0 A}{d}$

$$u = \frac{\epsilon_0}{2} \left( \frac{V}{d} \right)^2 \quad (6.16)$$

$$u = \frac{1}{2} \epsilon_0 E^2 \quad (6.17)$$

Therefore the electric energy density is proportional with square of the electric field.

$$.u \quad U$$

$$(6.17) \& (6.14)$$



**Example 6.5**

Three capacitors of  $8\mu\text{F}$ ,  $10\mu\text{F}$  and  $14\mu\text{F}$  are connected to a battery of  $12\text{V}$ . How much energy does the battery supply if the capacitors are connected (a) in series and (b) in parallel?



**Solution**

(a) For series combination

$$\frac{1}{C} = \frac{1}{C_1} + \frac{1}{C_2} + \frac{1}{C_3}$$

$$\frac{1}{C} = \frac{1}{8} + \frac{1}{10} + \frac{1}{14}$$

This gives

$$C = 3.37 \mu\text{F}$$

Then the energy  $U$  is

$$U = \frac{1}{2} CV^2$$

$$U = 1/2 (3.37 \times 10^{-6}) (12)^2 = 2.43 \times 10^{-4} \text{J}$$

(b) For parallel combination

$$C = C_1 + C_2 + C_3$$

$$C = 8 + 10 + 14 = 32 \mu\text{F}$$

The energy  $U$  is

$$U = 1/2 (32 \times 10^{-6}) (12)^2 = 2.3 \times 10^{-3} \text{J}$$



**Example 6.6**

A capacitor  $C_1$  is charged to a potential difference  $V_o$ . This charging battery is then removed and the capacitor is connected as shown in figure 6.9 to an uncharged capacitor  $C_2$ ,

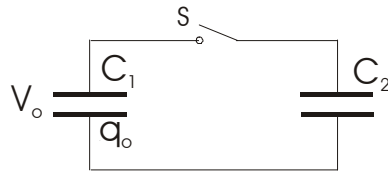

Figure 6.9

- (a) What is the final potential difference  $V_f$  across the combination?
- (b) What is the stored energy before and after the switch S is closed?



**Solution**

(a) The original charge  $q_o$  is shared between the two capacitors since they are connected in parallel. Thus

$$q_o = q_1 + q_2$$

$$q = CV$$

$$C_1V_o = C_1V_f + C_2V_f$$

$$V_f = V_o \frac{C_1}{C_1 + C_2}$$

(b) The initial stored energy is  $U_o$

$$U_o = \frac{1}{2}C_1V_o^2$$

The final stored energy  $U_f = U_1 + U_2$

$$U_f = \frac{1}{2}C_1V_f^2 + \frac{1}{2}C_2V_f^2 = \frac{1}{2}(C_1 + C_2) \left( \frac{V_o C_1}{C_1 + C_2} \right)^2$$

$$U_f = \left( \frac{C_1}{C_1 + C_2} \right) U_o$$

**Notice that  $U_f$  is less than  $U_o$  (Explain why)**



### Example 6.7

Consider the circuit shown in figure 6.10 where  $C_1=6\mu\text{F}$ ,  $C_2=3\mu\text{F}$ , and  $V=20\text{V}$ .  $C_1$  is first charged by closing switch  $S_1$ .  $S_1$  is then opened, and the charged capacitor  $C_1$  is connected to the uncharged capacitor  $C_2$  by closing the switch  $S_2$ . Calculate the initial charge acquired by  $C_1$  and the final charge on each of the two capacitors.

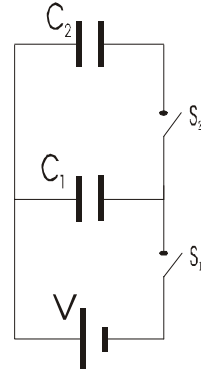

Figure 6.10



### Solution

When  $S_1$  is closed, the charge on  $C_1$  will be

$$Q_1 = C_1 V_1 = 6\mu\text{F} \times 20\text{V} = 120\mu\text{C}$$

When  $S_1$  is opened and  $S_2$  is closed, the total charge will remain constant and be distributed among the two capacitors,

$$Q_1 = 120\mu\text{C} - Q_2$$

The potential across the two capacitors will be equal,

$$V = \frac{Q_1}{C_1} = \frac{Q_2}{C_2}$$

$$\frac{120\mu\text{C} - Q_2}{6\mu\text{F}} = \frac{Q_2}{3\mu\text{F}}$$

Therefore,

$$Q_2 = 40\mu\text{C}$$

$$Q_1 = 120\mu\text{C} - 40\mu\text{C} = 80\mu\text{C}$$



**Example 6.8**

Consider the circuit shown in figure 6.11 where  $C_1=4\mu\text{F}$ ,  $C_2=6\mu\text{F}$ ,  $C_3=2\mu\text{F}$ , and  $V=35\text{V}$ .  $C_1$  is first charged by closing switch  $S$  to point 1.  $S$  is then connected to point 2 in the circuit.

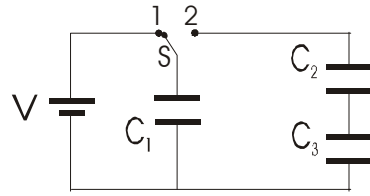

Figure 6.11

- Calculate the initial charge acquired by  $C_1$ ,
- Calculate the final charge on each of the three capacitors.
- Calculate the potential difference across each capacitor after the switch is connected to point 2.



**Solution**

When switch  $S$  is connected to point 1, the potential difference on  $C_1$  is 35V. Hence the charge  $Q_1$  is given by

$$Q_1 = C_1 \times V = 4 \times 35 = 140 \mu\text{C}$$

When switch  $S$  is connected to point 2, the charge on  $C_1$  will be distributed among the three capacitors. Notice that  $C_2$  and  $C_3$  are connected in series, therefore

$$\frac{1}{C'} = \frac{1}{C_2} + \frac{1}{C_3} = \frac{1}{6} + \frac{1}{2} = \frac{4}{6}$$

$$C' = 1.5 \mu\text{F}$$

We know that the charges are distributed equally on capacitor connected in series, but the charges are distributed with respect to their capacitance when they are connected in parallel. Therefore,

$$Q_1 = \frac{140}{4 + 1.5} \times 4 = 101.8 \mu\text{C}$$

But the charge  $Q'$  on the capacitor  $C'$  is

$$Q' = 140 - 101.8 = 38.2 \mu\text{C}$$

## Capacitors and capacitance

---

Since  $C_1$  and  $C_2$  are connected in series then

$$Q_2=Q_3=Q'=38.2\mu\text{C}$$

To find the potential difference on each capacitor we use the relation  $V=Q/C$

Then,

$$V_1=25.45\text{V}$$

$$V_2=6.37\text{V}$$

$$V_3=19.1\text{V}$$



### Example 6.9

Consider the circuit shown in figure 6.12 where  $C_1=6\mu\text{F}$ ,  $C_2=4\mu\text{F}$ ,  $C_3=12\mu\text{F}$ , and  $V=12\text{V}$ .

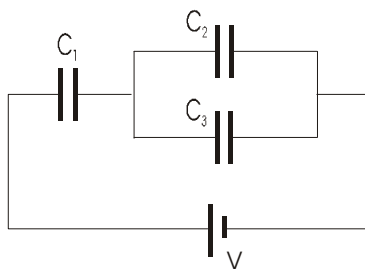

Figure 6.12

- Calculate the equivalent capacitance,
- Calculate the potential difference across each capacitor.
- Calculate the charge on each of the three capacitors.



**Solution**

$C_2$  and  $C_3$  are connected in parallel, therefore

$$C' = C_2 + C_3 = 4 + 12 = 16\mu\text{F}$$

Now  $C'$  is connected in series with  $C_1$ , therefore the equivalent capacitance is

$$\frac{1}{C} = \frac{1}{C'} + \frac{1}{C_1} = \frac{1}{6} + \frac{1}{16} = \frac{11}{48}$$

$$C = 4.36\mu\text{F}$$

The total charge  $Q = CV = 4.36 \times 12 = 52.36\mu\text{C}$

The charge will be equally distributed on the capacitor  $C_1$  and  $C'$

$$Q_1 = Q' = Q = 52.36\mu\text{C}$$

But  $Q' = C'V'$ , therefore

$$V' = 52.36/16 = 3.27 \text{ volts}$$

The potential difference on  $C_1$  is

$$V_1 = 12 - 3.27 = 8.73 \text{ volts}$$

The potential difference on both  $C_2$  and  $C_3$  is equivalent to  $V'$  since they are connected in parallel.

$$V_2 = V_3 = 3.27 \text{ volts}$$

$$Q_2 = C_2V_2 = 13.08\mu\text{C}$$

$$Q_3 = C_3V_3 = 39.24\mu\text{C}$$





**Example 6.9**

Four capacitors are connected as shown in Figure 6.13. (a) Find the equivalent capacitance between points a and b. (b) Calculate the charge on each capacitor if  $V_{ab}=15\text{V}$ .

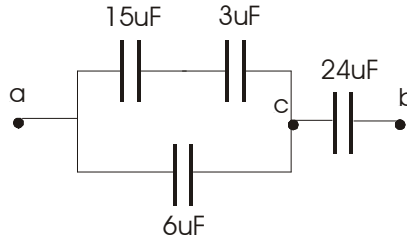
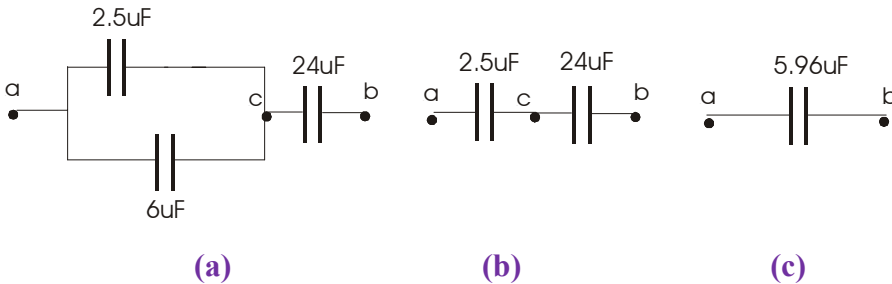

Figure 6.13



**Solution**

(a) We simplify the circuit as shown in the figure from (a) to (c).



First the  $15\mu\text{F}$  and  $3\mu\text{F}$  in series are equivalent to

$$\frac{1}{(1/15) + (1/3)} = 2.5\mu\text{F}$$

Next  $2.5\mu\text{F}$  combines in parallel with  $6\mu\text{F}$ , creating an equivalent capacitance of  $8.5\mu\text{F}$ .

The  $8.5\mu\text{F}$  and  $20\mu\text{F}$  are in series, equivalent to

$$\frac{1}{(1/8.5) + (1/20)} = 5.96\mu\text{F}$$

(b) We find the charge and the voltage across each capacitor by working backwards through solution figures (c) through (a).

For the  $5.96\mu\text{F}$  capacitor we have

$$Q = CV = 5.96 \times 15 = 89.5\mu\text{C}$$

In figure (b) we have, for the  $8.5\mu\text{F}$  capacitor,

$$\Delta V_{ac} = \frac{Q}{C} = \frac{89.5}{8.5} = 10.5V$$

and for the  $20\mu\text{F}$  in figure (b) and (a)  $Q_{20} = 89.5\mu\text{C}$

$$\Delta V_{cb} = \frac{Q}{C} = \frac{89.5}{20} = 4.47V$$

Next (a) is equivalent to (b), so  $\Delta V_{cb} = 4.47V$  and  $\Delta V_{ac} = 10.5V$

Thus for the  $2.5\mu\text{F}$  and  $6\mu\text{F}$  capacitors  $\Delta V = 10.5V$

$$Q_{2.5} = CV = 2.5 \times 10.5 = 26.3\mu\text{C}$$

$$Q_6 = CV = 6 \times 10.5 = 63.2\mu\text{C}$$

Therefore

$$Q_{15} = 26.3\mu\text{C} \quad Q_3 = 26.3\mu\text{C}$$

For the potential difference across the capacitors  $C_{15}$  and  $C_3$  are

$$\Delta V_{15} = \frac{Q}{C} = \frac{26.3}{15} = 1.75V$$

$$\Delta V_3 = \frac{Q}{C} = \frac{26.3}{3} = 8.77V$$

## 6.6 Capacitor with dielectric

A dielectric is a non-conducting material, such as rubber, glass or paper. Experimentally it was found that the capacitance of a capacitor increased when a dielectric material was inserted in the space between the plates. The ratio of the capacitance with the dielectric to that without it called the dielectric constant  $\kappa$  of the material.

$$\kappa = \frac{C}{C_o} \quad (6.18)$$

In figure 6.14 below two similar capacitors, one of them is filled with dielectric material, and both are connected in parallel to a battery of potential  $V$ . It was found that the charge on the capacitor with dielectric is larger than the on the air filled capacitor, therefore the  $C_d > C_o$ , since the potential  $V$  is the same on both capacitors.

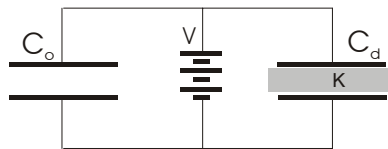

Figure 6.14

If the experiment repeated in different way by placing the same charge  $Q_o$  on both capacitors as shown in figure 6.15. Experimentally it was shown that  $V_d < V_o$  by a factor of  $1/\kappa$ .

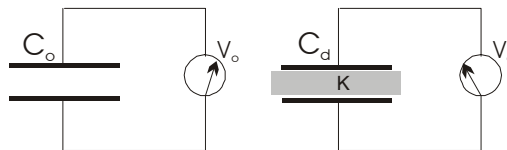

Figure 6.15

$$V_d = \frac{V_o}{\kappa} \quad (6.19)$$

Since the charge  $Q_o$  on the capacitors does not change, then

$$C = \frac{Q_o}{V_d} = \frac{Q_o}{V_o/\kappa} = \kappa \frac{Q_o}{V_o} \quad (6.20)$$

For a parallel plate capacitor with dielectric we can write the capacitance.

$$C = \kappa \frac{\epsilon_o A}{d} \quad (6.21)$$



### Example 6.10

A parallel plate capacitor of area  $A$  and separation  $d$  is connected to a battery to charge the capacitor to potential difference  $V_o$ . Calculate the stored energy before and after introducing a dielectric material.



### Solution

The energy stored before introducing the dielectric material,

$$U_o = \frac{1}{2} C_o V_o^2$$

The energy stored after introducing the dielectric material,

$$C = \kappa C_o \quad \text{and} \quad V_d = \frac{V_o}{\kappa}$$

$$U = \frac{1}{2} C V^2 = \frac{1}{2} \kappa C_o \left( \frac{V_o}{\kappa} \right)^2 = \frac{U_o}{\kappa}$$

Therefore, the energy is less by a factor of  $1/\kappa$ .

---

---



**Example 6.11**

A Parallel plate capacitor of area  $0.64\text{cm}^2$ . When the plates are in vacuum, the capacitance of the capacitor is  $4.9\text{pF}$ .

- (a) Calculate the value of the capacitance if the space between the plates is filled with nylon ( $\kappa=3.4$ ).
- (b) What is the maximum potential difference that can be applied to the plates without causing discharge ( $E_{\text{max}}=14\times 10^6\text{V/m}$ )?



**Solution**

(a)  $C = \kappa C_o = 3.4 \times 4.9 = 16.7\text{pF}$

(b)  $V_{\text{max}} = E_{\text{max}} \times d$

To evaluate  $d$  we use the equation

$$d = \frac{\epsilon_o A}{C_o} = \frac{8.85 \times 10^{-12} \times 6.4 \times 10^{-5}}{4.9 \times 10^{-12}} = 1.16 \times 10^{-4} \text{m}$$

$$V_{\text{max}} = 1 \times 10^6 \times 1.16 \times 10^{-4} = 1.16 \times 10^3 \text{V}$$



**Example 6.12**

A parallel-plate capacitor has a capacitance  $C_o$  in the absence of dielectric. A slab of dielectric material of dielectric constant  $\kappa$  and thickness  $d/3$  is inserted between the plates as shown in Figure 6.16. What is the new capacitance when the dielectric is present?

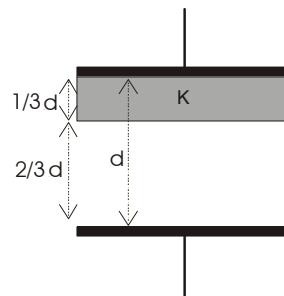

Figure 6.16



**Solution**

We can assume that two parallel plate capacitor are connected in series as shown in figure 6.17,

$$C_1 = \frac{\kappa \epsilon_o A}{d/3} \quad \text{and} \quad C_2 = \frac{\epsilon_o A}{2d/3}$$

$$\frac{1}{C} = \frac{1}{C_1} + \frac{1}{C_2} = \frac{d/3}{\kappa \epsilon_o A} + \frac{2d/3}{\epsilon_o A}$$

$$\frac{1}{C} = \frac{d}{3\epsilon_o A} \left( \frac{1}{\kappa} + 2 \right) = \frac{d}{3\epsilon_o A} \left( \frac{1+2\kappa}{\kappa} \right)$$

$$C = \left( \frac{3\kappa}{2\kappa+1} \right) \frac{\epsilon_o A}{d} \quad \Rightarrow \quad C = \left( \frac{3\kappa}{2\kappa+1} \right) C_o$$

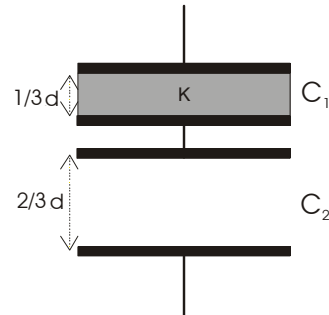

Figure 6.17



## 6.7 Problems

---

6.1) Two capacitors,  $C_1=2\mu\text{F}$  and  $C_2=16\mu\text{F}$ , are connected in parallel. What is the value of the equivalent capacitance of the combination?

6.2) Calculate the equivalent capacitance of the two capacitors in the previous exercise if they are connected in series.

6.3) A  $100\text{pF}$  capacitor is charged to a potential difference of  $50\text{V}$ , the charging battery then being disconnected. The capacitor is then connected in parallel with a second (initially uncharged) capacitor. If the measured potential difference drops to  $35\text{V}$ , what is the capacitance of this second capacitor?

6.4) A parallel-plate capacitor has circular plates of  $8.0\text{cm}$  radius and  $1.0\text{mm}$  separation. What charge will appear on the plates if a potential difference of  $100\text{V}$  is applied?

6.5) In figure 6.18 the battery supplies  $12\text{V}$ . (a) Find the charge on each capacitor when switch  $S_1$  is closed, and (b) when later switch  $S_2$  is also closed. Assume  $C_1=1\mu\text{F}$ ,  $C_2=2\mu\text{F}$ ,  $C_3=3\mu\text{F}$ , and  $C_4=4\mu\text{F}$ .

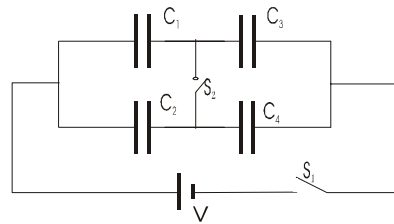

Figure 6.18

6.6) A parallel plate capacitor has a plate of area  $A$  and separation  $d$ , and is charged to a potential difference  $V$ . The charging battery is then disconnected and the plates are pulled apart until their separation is  $2d$ . Derive expression in term of  $A$ ,  $d$ , and  $V$  for, the new potential difference, the initial and final stored energy, and the work required to separate the plates.

6.7) A  $6.0\mu\text{F}$  capacitor is connected in series with a  $4.0\mu\text{F}$  capacitor and a potential difference of  $200\text{V}$  is applied across the pair. (a) What is the charge on each capacitor? (b) What is the potential difference across each capacitor?

6.8) Repeat the previous problem for the same two capacitors connected in parallel.

6.9) Show that the plates of a parallel-plate capacitor attract each other with a force given by

$$F = \frac{q^2}{2\epsilon_0 A}$$

Calculate the total stored energy in the system.

- 6.10) A parallel-plate air capacitor having area  $A$  ( $40\text{cm}^2$ ) and spacing  $d$  ( $1.0\text{ mm}$ ) is charged to a potential  $V$  ( $600\text{V}$ ). Find (a) the capacitance, (b) the magnitude of the charge on each plate, (c) the stored energy, (d) the electric field between the plates and (e) the energy density between the plates.
- 6.11) How many  $1\mu\text{F}$  capacitors would need to be connected in parallel in order to store a charge  $1\text{C}$  with potential of  $300\text{V}$  across the capacitors?
- 6.12) In figure 6.19 (a)&(b) find the equivalent capacitance of the combination. Assume that  $C_1=10\mu\text{F}$ ,  $C_2=5\mu\text{F}$ , and  $C_3=4\mu\text{F}$ .
- 6.14) A  $16\text{pF}$  parallel-plate capacitor is charged by a  $10\text{V}$  battery. If each plate of the capacitor has an area of  $5\text{cm}^2$ , what is the energy stored in the capacitor? What is the energy density (energy per unit volume) in the electric field of the capacitor if the plates are separated by air?
- 6.15) The energy density in a parallel-plate capacitor is given as  $2.1 \times 10^{-9}\text{J/m}^3$ . What is the value of the electric field in the region between the plates?
- 6.16) (a) Determine the equivalent capacitance for the capacitors shown in figure 6.20. (b) If they are connected to  $12\text{V}$  battery, calculate the potential difference across each capacitor and the charge on each capacitor

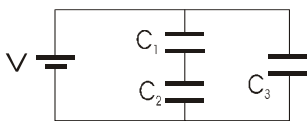

Figure 6.19(a)

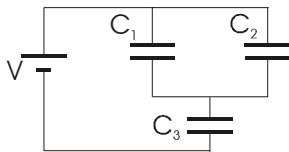

Figure 6.19(b)

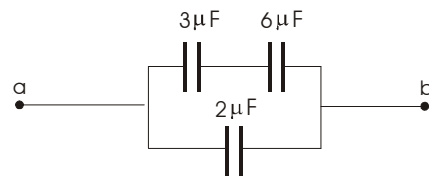

Figure 6.20

- 6.13) Two capacitors ( $2.0\mu\text{F}$  and  $4.0\mu\text{F}$ ) are connected in parallel across a  $300\text{V}$  potential difference.
- 6.17) Evaluate the effective capacitance of the configuration shown in Figure 6.21. Each of the capacitors is identical and has capacitance  $C$ .



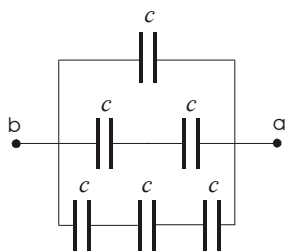

Figure 6.21

6.18) A parallel plate capacitor is constructed using a dielectric material whose dielectric constant is 3 and whose dielectric strength is  $2 \times 10^8 \text{V/m}$ . The desired capacitance is  $0.25 \mu\text{F}$ , and the capacitor must withstand a maximum potential difference of  $4000 \text{V}$ . Find the maximum area of the capacitor plate.

6.19) In figure 6.19(b) find (a) the charge, (b) the potential difference, (c) the stored energy for each capacitor. With  $V=100 \text{V}$ .

6.20) (a) Figure 6.22 shows a network of capacitors between the terminals  $a$  and  $b$ . Reduce this network to a single equivalent capacitor. (b) Determine the charge on the  $4 \mu\text{F}$  and  $8 \mu\text{F}$  capacitors when the capacitors are fully charged by a  $12 \text{V}$  battery connected to the terminals. (c) Determine the potential difference across each capacitor.

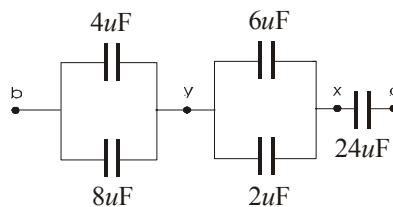

Figure 6.22

6.21) A uniform electric field  $E=3000 \text{V/m}$  exists within a certain region. What volume of space would contain an energy equal to  $10^{-7} \text{J}$ ? Express your answer in cubic meters and in liters.

6.22) A capacitor is constructed from two square metal plates of side length  $L$  and separated by a distance  $d$  (Figure 6.23). One half of the space between the plates (top to bottom) is filled with polystyrene ( $\kappa=2.56$ ), and the other half is filled with neoprene rubber ( $\kappa=6.7$ ). Calculate the capacitance of the device, taking  $L=2 \text{cm}$  and  $d=0.75 \text{mm}$ . (Hint: The capacitor can be considered as two capacitors connected in parallel.)

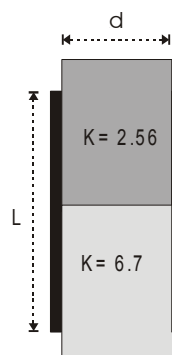
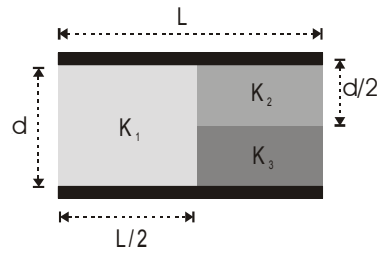

Figure 6.23

6.23) A parallel plate capacitor is constructed using three different dielectric materials, as shown in figure 6.24. (a) Find an expression for the capacitance in terms of the plate area  $A$  and  $\kappa_1$ ,  $\kappa_2$ , and  $\kappa_3$ . (b) Calculate the capacitance using the value  $A=1\text{cm}^2$ ,  $d=2\text{mm}$ ,  $\kappa_1=4.9$ ,  $\kappa_2=5.6$ , and  $\kappa_3=2.1$ .



*Figure 6.24*

**LECTURES IN GENERAL PHYSICS**

# *Electrostatic*

*Principles and Applications*

Dr. Hazem Falah Sakeek

Al-Azhar University - Gaza

*Part Two*

# Chapter 7

## *Current and Resistance*

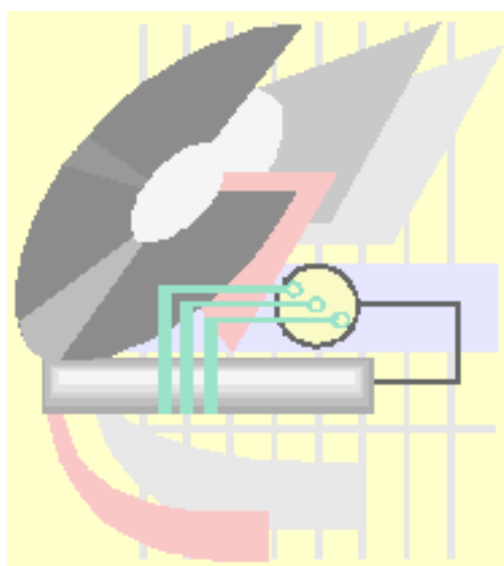

# Current and Resistance

**7.1 Current and current density**

**7.2 Definition of current in terms of the drift velocity**

**7.3 Definition of the current density**

**7.4 Resistance and resistivity (Ohm's Law)**

**7.5 Evaluation of the resistance of a conductor**

**7.6 Electrical Energy and Power**

**7.7 Combination of Resistors**

7.7.1 Resistors in Series

7.7.2 Resistors in Parallel

**7.8 Solution of some selected problems**

**7.9 Problems**

# *Current and Resistance*

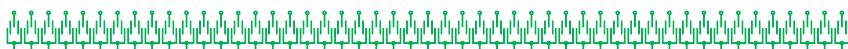

" "

.

.



## 7.1 Current and current density

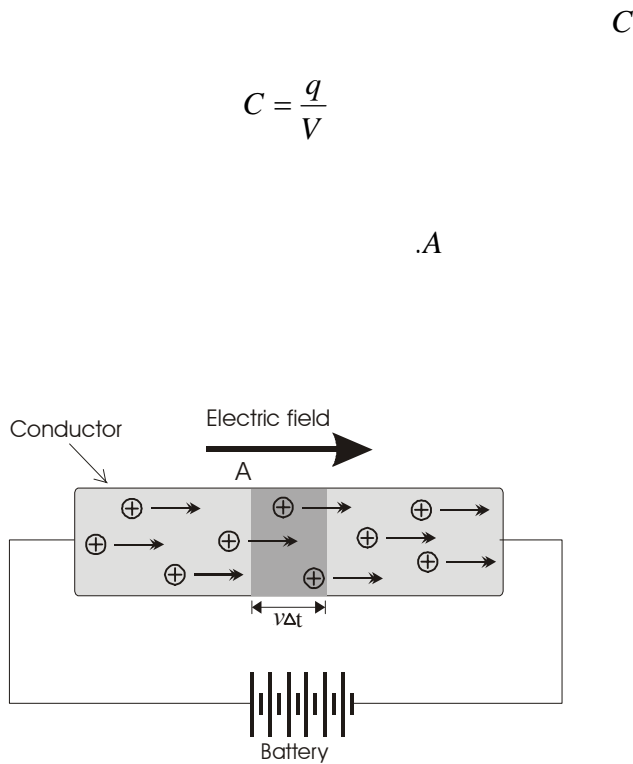

Figure 7.1

As shown in figure 7.1 above the electric field produces electric force ( $F=qE$ ), this force leads the free charge in the conductor to move in one direction with an average velocity called **drift velocity**.

The current is defined by the net charge flowing across the area  $A$  per unit time. Thus if a net charge  $\Delta Q$  flow across a certain area in time interval  $\Delta t$ , the average current  $I_{av}$  across this area is

$$I_{av} = \frac{\Delta Q}{\Delta t} \quad (7.1)$$

In general the current  $I$  is

$$I = \frac{dQ}{dt} \quad (7.2)$$

Current is a *scalar* quantity and has a unit of  $C/t$ , which is called *ampere*.

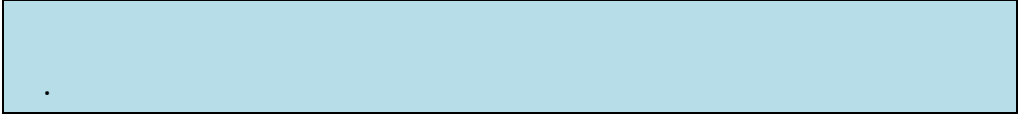

## 7.2 Definition of current in terms of the drift velocity

Consider figure 7.1 shown above. Suppose there are  $n$  positive charge particle per unit volume moves in the direction of the field from the left to the right, all move in drift velocity  $v$ . In time  $\Delta t$  each particle moves distance  $v\Delta t$  the shaded area in the figure, The volume of the shaded area in the figure is equal  $nAv\Delta t$ , the charge  $\Delta Q$  flowing across the end of the cylinder in time  $\Delta t$  is

$$\Delta Q = nqvA\Delta t \quad (7.3)$$

where  $q$  is the charge of each particle.

Then the current  $I$  is

$$I = \frac{\Delta Q}{\Delta t} = nqvA \quad (7.4)$$

## 7.3 Definition of the current density

The current per unit cross-section area is called the current density  $J$ .

$$\vec{J} = \frac{I}{A} = nqv \quad (7.5)$$

The current density is a vector quantity.





**Example 7.1**

A copper conductor of square cross section  $1\text{mm}^2$  on a side carries a constant current of  $20\text{A}$ . The density of free electrons is  $8 \times 10^{28}$  electron per cubic meter. Find the current density and the drift velocity.



**Solution**

The current density is

$$J = \frac{I}{A} = 10 \times 10^6 \text{ A/m}^2$$

The drift velocity is

$$v = \frac{J}{nq} = \frac{20 \times 10^6}{(8 \times 10^{28})(1.6 \times 10^{-9})} = 1.6 \times 10^{-3} \text{ m/s}$$

*This drift velocity is very small compare with the velocity of propagation of current pulse, which is  $3 \times 10^8 \text{m/s}$ . The smaller value of the drift velocity is due to the collisions with atoms in the conductor.*

---

## 7.4 Resistance and resistivity (Ohm's Law)

The resistance  $R$  of a conductor is defined as the ratio  $V/I$ , where  $V$  is the potential difference across the conductor and  $I$  is the current flowing in it. Thus if the same potential difference  $V$  is applied to two conductors  $A$  and  $B$ , and a smaller current  $I$  flows in  $A$ , then the resistance of  $A$  is greater than  $B$ , therefore we write,

$$R = \frac{V}{I} \quad \text{Ohm's law} \quad (7.6)$$

This equation is known as Ohm's law, which shows that a linear relationship between the potential difference and the current flowing in the conductor. Any conductor showing the linear behavior its resistance is called *ohmic* resistance.

The resistance  $R$  has a unit of volt/ampere ( $v/A$ ), which is called *Ohm* ( $\Omega$ ).

From the above equation, it also follows that

$$V = IR \quad \text{and} \quad I = \frac{V}{R}$$

The resistance in the circuit is drawn using this symbol

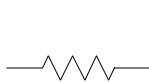

Fixed resistor



Variable resistor

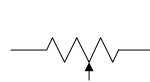

Potential divider

Each material has different resistance; therefore it is better to use the resistivity  $\rho$ , it is defined from

$$\rho = \frac{E}{J} \quad (7.8)$$

The resistivity has unit of  $\Omega \cdot m$

The inverse of resistivity is known as the conductivity  $\sigma$ ,

$$\sigma = \frac{1}{\rho} \quad (7.9)$$

## 7.5 Evaluation of the resistance of a conductor

Consider a cylindrical conductor as shown in figure 7.2, of cross-sectional area  $A$  and length  $\ell$ , carrying a current  $I$ . If a potential difference  $V$  is connected to the ends the conductor, the electric field and the current density will have the values

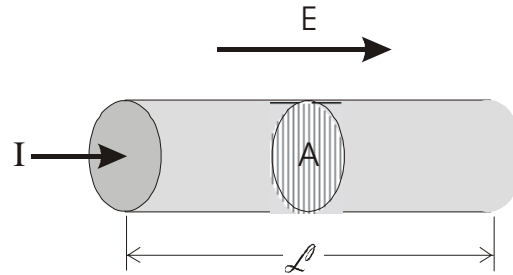

Figure 7.2

$$E = \frac{V}{\ell} \quad (7.10)$$

and

$$J = \frac{I}{A}$$

The resistivity  $\rho$  is

$$\rho = \frac{E}{J} = \frac{V/I}{I/A} \quad (7.11)$$

But the  $V/I$  is the resistance  $R$  this leads to,

$$R = \rho \frac{\ell}{A} \quad (7.12)$$

Therefore, the resistance  $R$  is proportional to the length  $\ell$  of the conductor and inversely proportional the cross-sectional area  $A$  of it.

*Notice that the resistance of a conductor depends on the geometry of the conductor, and the resistivity of the conductor depends only on the electronic structure of the material.*



### Example 7.2

Calculate the resistance of a piece of aluminum that is 20cm long and has a cross-sectional area of  $10^{-4}\text{m}^2$ . What is the resistance of a piece of glass with the same dimensions?  $\rho_{Al}=2.82\times 10^{-8}\Omega\cdot\text{m}$ ,  $\rho_{glass}=10^{10}\Omega\cdot\text{m}$ .



### Solution

The resistance of aluminum

$$R_{Al} = \rho \frac{\ell}{A} = 2.82 \times 10^{-8} \left( \frac{0.1}{10^{-4}} \right) = 2.82 \times 10^{-5} \Omega$$

The resistance of glass

$$R_{glass} = \rho \frac{\ell}{A} = 10^{10} \left( \frac{0.1}{10^{-4}} \right) = 10^{13} \Omega$$

Notice that the resistance of aluminum is much smaller than glass.

---



### Example 7.3

A 0.90V potential difference is maintained across a 1.5m length of tungsten wire that has a cross-sectional area of  $0.60\text{mm}^2$ . What is the current in the wire?



### Solution

From Ohm's law

$$I = \frac{V}{R} \quad \text{where} \quad R = \rho \frac{\ell}{A}$$

therefore,

$$I = \frac{VA}{\rho\ell} = \frac{(0.90)(6.0 \times 10^{-7})}{(5.6 \times 10^{-8})(1.5)} = 6.43\text{A}$$



**Example 7.4**

(a) Calculate the resistance per unit length of a 22 nichrome wire of radius 0.321mm. (b) If a potential difference of 10V is maintained across a 1m length of nichrome wire, what is the current in the wire.  $\rho_{nichrome} = 1.5 \times 10^{-6} \Omega \cdot m$ .



**Solution**

(a) The cross sectional area of the wire is

$$A = \pi r^2 = \pi (0.321 \times 10^{-3})^2 = 3.24 \times 10^{-7} m^2$$

The resistance per unit length is  $R/\ell$

$$\frac{R}{\ell} = \frac{\rho}{A} = \frac{1.5 \times 10^{-6}}{3.24 \times 10^{-7}} = 4.6 \Omega / m$$

(b) The current in the wire is

$$I = \frac{V}{R} = \frac{10}{4.6} = 2.2 A$$

Nichrome wire is often used for heating elements in electric heater, toaster and irons, since its resistance is 100 times higher than the copper wire.

	Material	Resistivity ( $\Omega \cdot m$ )
1	Silver	$1.59 \times 10^{-8}$
2	Copper	$1.7 \times 10^{-8}$
3	Gold	$2.44 \times 10^{-8}$
4	Aluminum	$2.82 \times 10^{-8}$
5	Tungsten	$5.6 \times 10^{-8}$
6	Iron	$10 \times 10^{-8}$
7	Platinum	$11 \times 10^{-8}$
8	Lead	$20 \times 10^{-8}$
9	Nichrome	$150 \times 10^{-8}$
10	Carbon	$3.5 \times 10^{-5}$
11	Germanium	0.46
12	Silicon	640
13	Glass	$10^{10} - 10^{14}$

Table (7.1) Resistivity of various materials at 20°C

## 7.6 Electrical Energy and Power

The current can flow in circuit when a battery is connected to an electrical device through conducting wire as shown in figure 7.3. If the positive terminal of the battery is connected to  $a$  and the negative terminal of the battery is connected to  $b$  of the device. A charge  $dq$  moves through the device from  $a$  to  $b$ . The battery perform a work  $dW = dq V_{ab}$ . This work is by the battery is energy  $dU$  transferred to the device in time  $dt$  therefore,

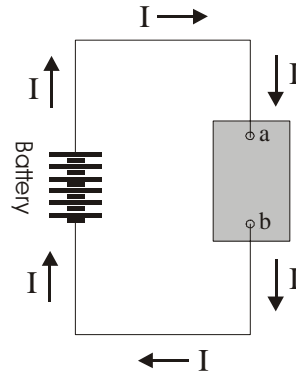

Figure 7.3

$$dU = dW = dq V_{ab} = I dt V_{ab} \quad (7.13)$$

The rate of electric energy ( $dU/dt$ ) is an electric power ( $P$ ).

$$P = \frac{dU}{dt} = I V_{ab} \quad (7.14)$$

Suppose a resistor replaces the electric device, the electric power is

$$P = I^2 R \quad (7.15)$$

$$P = \frac{V^2}{R} \quad (7.16)$$

The unit of power is (*Joule/sec*) which is known as *watt* ( $W$ ).



**Example 7.5**

An electric heater is constructed by applying a potential difference of 110volt to a nichrome wire of total resistance  $8\Omega$ . Find the current carried by the wire and the power rating of the heater.



**Solution**

Since  $V = IR$

$$\therefore I = \frac{V}{R} = \frac{110}{8} = 13.8A$$

The power  $P$  is

$$P = I^2R = (13.8)^2 \times 8 = 1520W$$

---



**Example 7.6**

A light bulb is rated at 120v/75W. The bulb is powered by a 120v. Find the current in the bulb and its resistance.



**Solution**

$$P = IV$$

$$\therefore I = \frac{P}{V} = \frac{75}{120} = 0.625A$$

The resistance is

$$R = \frac{V}{I} = \frac{120}{0.625} = 192\Omega$$

---

---

## 7.7 Combination of Resistors

Some times the electric circuit consist of more than two resistors, which are, connected either in parallel or in series the equivalent resistance is evaluated as follow:

### 7.7.1 Resistors in Series:

The figure 7.4 shows three resistor in series, carrying a current  $I$ .

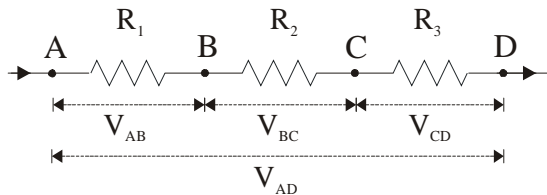

Figure 7.4

*For a series connection of resistors, the current is the same in each resistor.*

If  $V_{AD}$  is the potential difference across the whole resistors, the electric energy supplied to the system per second is  $IV_{AD}$ . This is equal to the electric energy dissipated per second in all the resistors.

$$IV_{AD} = IV_{AB} + IV_{BC} + IV_{CD} \quad (7.17)$$

Hence

$$V_{AD} = V_{AB} + V_{BC} + V_{CD} \quad (7.18)$$

The individual potential differences are

$$V_{AB} = IR_1, \quad V_{BC} = IR_2, \quad V_{CD} = IR_3$$

Therefore

$$V_{AD} = IR_1 + IR_2 + IR_3 \quad (7.19)$$

$$V_{AD} = I(R_1 + R_2 + R_3) \quad (7.20)$$

The equivalent resistor is

$$R = R_1 + R_2 + R_3 \quad (7.21)$$



### 7.7.2 Resistors in Parallel:

The figure 7.5 shows three resistor in parallel, between the points A and B, A current  $I$  enter from point A and leave from point B, setting up a potential difference  $V_{AB}$ .

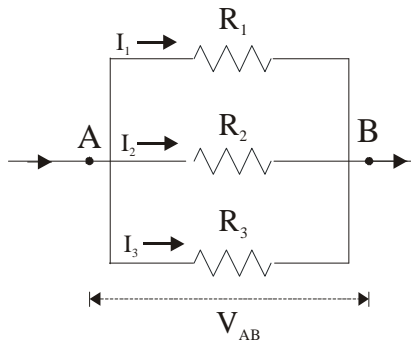

Figure 7.5

*For a parallel connection of resistors, the potential difference is equal across each resistor.*

The current branches into  $I_1$ ,  $I_2$ ,  $I_3$ , through the three resistors and,

$$I = I_1 + I_2 + I_3 \quad (7.22)$$

The current in each branch is given by

$$I_1 = \frac{V_{AB}}{R_1}, \quad I_2 = \frac{V_{AB}}{R_2}, \quad I_3 = \frac{V_{AB}}{R_3}$$

$$\therefore I = V_{AB} \left( \frac{1}{R_1} + \frac{1}{R_2} + \frac{1}{R_3} \right) \quad (7.23)$$

The equivalent resistance is

$$\therefore \frac{1}{R} = \frac{1}{R_1} + \frac{1}{R_2} + \frac{1}{R_3} \quad (7.24)$$

**Physical facts for the series and parallel  
combination of resistors**

No.	Series combination	Parallel combination
1	Current is the same through all resistors	Potential difference is the same through all resistors
2	Total potential difference = sum of the individual potential difference	Total Current = sum of the individual current
3	Individual potential difference directly proportional to the individual resistance	Individual current inversely proportional to the individual resistance
4	Total resistance is greater than greatest individual resistance	Total resistance is less than least individual resistance

*Notice that parallel resistors combine in the same way that series capacitors combine, and vice versa.*



**Example 7.6**

Find the equivalent resistance for the circuit shown in figure 7.6.  
 $R_1=3\Omega$ ,  $R_2=6\Omega$ , and  $R_3=4\Omega$ .

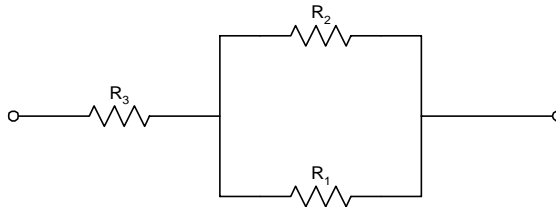
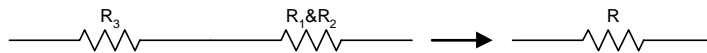

Figure 7.6



**Solution**

Resistance  $R_1$  and  $R_2$  are connected in parallel therefore the circuit is simplify as shown below



$$\frac{1}{R'} = \frac{1}{R_1} + \frac{1}{R_2}$$

$$\frac{1}{R'} = \frac{1}{3} + \frac{1}{6} = \frac{3}{6}$$

$$R' = 2\Omega$$

Then the resultant resistance of  $R_1 \& R_2$  ( $R'$ ) are connected in series with resistance  $R_3$

$$R = R' + R_3 = 2 + 4 = 6\Omega$$



**Example 7.7**

Find the equivalent resistance for the circuit shown in figure 7.7.  
 $R_1=4\Omega$ ,  $R_2=3\Omega$ ,  $R_3=3\Omega$ ,  $R_4=5\Omega$ , and  $R_5=2.9\Omega$ .

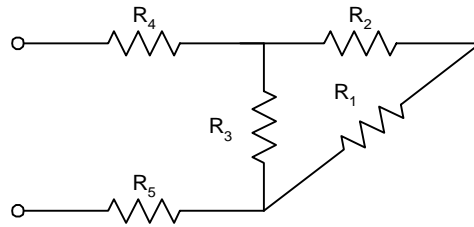
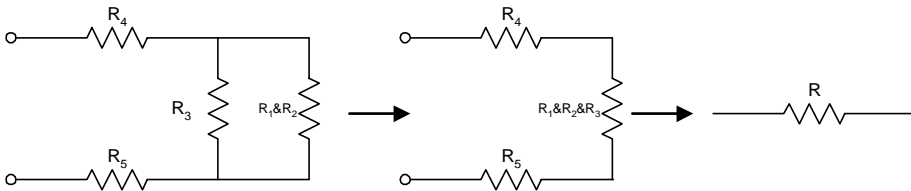

Figure 7.7



**Solution**

Resistance  $R_1$  and  $R_2$  are connected in series therefore the circuit is simplify as shown below



$$R' = R_1 + R_2 = 4 + 3 = 7\Omega$$

Then the resultant resistance of  $R_1 \& R_2$  ( $R'$ ) are connected in parallel with resistance  $R_3$

$$\frac{1}{R''} = \frac{1}{R'} + \frac{1}{R_3} = \frac{1}{7} + \frac{1}{3} = \frac{10}{21}$$

$$R'' = 2.1\Omega$$

The resultant resistance  $R$  for  $R_5 \& R_4 \& R''$  are connected in series.

$$R = R'' + R_5 + R_4 = 2.1 + 5 + 2.9 = 10\Omega$$



**Example 7.8**

Three resistors are connected in parallel as in shown in figure 7.8. A potential difference of 18V is maintained between points  $a$  and  $b$ .

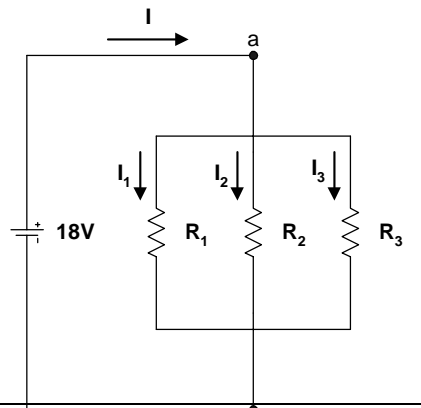

Figure 7.8

- (a) find the current in each resistor. (b) Calculate the power dissipated by each resistor and the total power dissipated by the three resistors. (c) Calculate the equivalent resistance, and from this result find the total power dissipated.



### Solution

To find the current in each resistor, we make use of the fact that the potential difference across each of them is equal to 18v, since they are connected in parallel with the battery.

Applying  $V=IR$  to get the current flow in each resistor and then apply  $P = I^2R$  to get the power dissipated in each resistor.

$$I_1 = \frac{V}{R_1} = \frac{18}{3} = 6A \quad \Rightarrow \quad P_1 = I_1^2 R_1 = 108W$$

$$I_2 = \frac{V}{R_2} = \frac{18}{6} = 3A \quad \Rightarrow \quad P_2 = I_2^2 R_2 = 54W$$

$$I_3 = \frac{V}{R_3} = \frac{18}{9} = 2A \quad \Rightarrow \quad P_3 = I_3^2 R_3 = 36W$$

The equivalent resistance  $R_{eq}$  is

$$\frac{1}{R_{eq}} = \frac{1}{3} + \frac{1}{6} + \frac{1}{9} = \frac{11}{18}$$

$$R_{eq} = 1.6 \Omega$$

---

---

## **7.8 Solution of some selected problems**



## 7.8 Solution of some selected problems



### Example 7.9

Two wires  $A$  and  $B$  of circular cross section are made of the same metal and have equal length, but the resistance of wire  $A$  is three times greater than that of wire  $B$ . What is the ratio of their cross-sectional area? How do their radii compare?



### Solution

Since  $R = \rho L/A$ , the ratio of the resistance  $R_A/R_B = A_B/A_A$ . Hence, the ratio is three times. That is, the area of wire  $B$  is three times that of  $A$ .

The radius of wire  $b$  is  $\sqrt{3}$  times the radius of wire  $A$ .

---



### Example 7.10

Two conductors of the same length and radius are connected across the same potential difference. One conductor has twice the resistance of the other. Which conductor will dissipate more power?



### Solution

Since the power dissipated is given by  $P = V^2/R$ , the conductor with the lower resistance will dissipate more power.

---



### Example 7.11

Two light bulbs both operate from 110v, but one has power rating 25W and the other of 100W. Which bulb has the higher resistance? Which bulb carries the greater current?



### Solution

Since  $P=V^2/R$ , and  $V$  is the same for each bulb, the 25W bulb would have the higher resistance. Since  $P=IV$ , then the 100W bulb carries the greater current.

---



### Example 7.12

The current  $I$  in a conductor depends on time as  $I=2t^2-3t+7$ , where  $t$  is in sec. What quantity of charge moves across a section through the conductor during time interval  $t=2\text{sec}$  to  $t=4\text{sec}$ ?



### Solution

$$I = \frac{dQ}{dt}; \quad dQ = I dt$$

$$Q = \int Idt = \int_2^4 (2t^2 - 3t + 7) dt$$

$$Q = [2t^3 - 3t^2 + 7t]_2^4 = 33.3C$$

---





**Example 7.13**

A 2.4m length of wire that is  $0.031\text{cm}^2$  in cross section has a measured resistance of  $0.24\Omega$ . Calculate the conductivity of the material.



**Solution**

$$R = \rho \frac{L}{A} \quad \text{and} \quad \rho = \frac{1}{\sigma} \quad \text{therefore}$$

$$\sigma = \frac{L}{RA} = \frac{2.4}{(0.24)(3.1 \times 10^{-6})} = 3.23 \times 10^6 / \Omega.m$$

---



**Example 7.14**

A 0.9V potential difference is maintained across a 1.5m length of tungsten wire that has cross-sectional area of  $0.6\text{mm}^2$ . What is the current in the wire?



**Solution**

From Ohm's law,

$$I = \frac{V}{R} \quad \text{where} \quad R = \rho \frac{L}{A} \quad \text{therefore}$$

$$I = \frac{VA}{\rho L} = \frac{0.9 \times 6 \times 10^{-7}}{5.6 \times 10^{-8} \times 1.5} = 6.43\text{A}$$

---

---



**Example 7.15**

A resistor is constructed by forming a material of resistivity  $\rho$  into the shape of a hollow cylinder of length  $L$  and inner and outer radii  $r_a$  and  $r_b$  respectively as shown in figure 7.9. In use, a potential difference is applied between the ends of the cylinder, producing a current parallel to the axis. (a) Find a general expression for the resistance of such a device in terms of  $L$ ,  $\rho$ ,  $r_a$ , and  $r_b$ . (b) Obtain a numerical value for  $R$  when  $L=4\text{cm}$ ,  $r_a=0.5\text{cm}$ ,  $r_b=1.2\text{cm}$ , and  $\rho=3.5\times 10^5\Omega\cdot\text{m}$ .

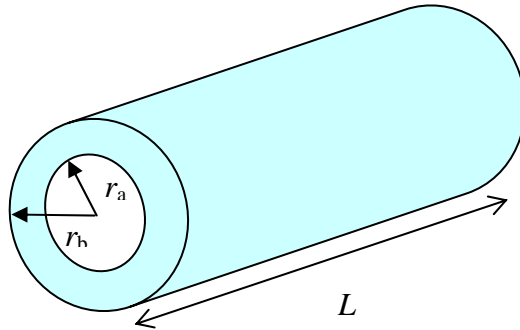

Figure 7.9



**Solution**

(a) 
$$R = \rho \frac{L}{A} = \frac{\rho L}{\pi(r_b^2 - r_a^2)}$$

(b) 
$$R = \frac{\rho L}{\pi(r_b^2 - r_a^2)} = \frac{(3.5 \times 10^5)(0.04)}{\pi[(0.012)^2 - (0.005)^2]} = 3.74 \times 10^7 \Omega$$



**Example 7.16**

If a  $55\Omega$  resistor is rated at  $125W$ , what is the maximum allowed voltage?



**Solution**

$$P = \frac{V^2}{R}$$

$$\therefore V = \sqrt{PR} = \sqrt{125 \times 55} = 82.9V$$



## 7.9 Problems

---

- 7.1) A current of 5A exists in a  $10\ \Omega$  resistor for 4min. (a) How many coulombs, and (b) how many electrons pass through any cross section of the resistor in this time?
- 7.2) A small but measurable current of  $1.0 \times 10^{-10}$  A exists in a copper wire whose diameter is 0.10in. Calculate the electron drift speed.
- 7.3) A square aluminum rod is 1.0m long and 5.0mm on edge. (a) What is the resistance between its ends? (b) What must be the diameter of a circular 1.0m copper rod if its resistance is to be the same?
- 7.4) A conductor of uniform radius 1.2cm carries a current of 3A produced by an electric field of 120V/m. What is the resistivity of the material?
- 7.5) If the current density in a copper wire is equal to  $5.8 \times 10^6$  A/m<sup>2</sup>, calculate the drift velocity of the free electrons in this wire.
- 7.6) A 2.4m length of wire that is  $0.031\text{cm}^2$  in cross section has a measured resistance of  $0.24\ \Omega$ . Calculate the conductivity of the material.
- 7.7) Aluminium and copper wires of equal length are found to have the same resistance. What is the ratio of their radii?
- 7.8) What is the resistance of a device that operates with a current of 7A when the applied voltage is 110V?
- 7.9) A copper wire and an iron wire of the same length have the same potential difference applied to them. (a) What must be the ratio of their radii if the current is to be the same? (b) Can the current density be made the same by suitable choices of the radii?
- 7.10) A 0.9V potential difference is maintained across a 1.5m length of tungsten wire that has a cross-sectional area of  $0.6\text{mm}^2$ . What is the current in the wire?
- 7.11) A wire with a resistance of  $6.0\ \Omega$  is drawn out through a die so that its new length is three times its original length. Find the resistance of the longer wire, assuming that the resistivity and density of the material are not changed during the drawing process.
- 7.12) A wire of Nichrome (a nickel-chromium alloy commonly used in

- heating elements) is 1.0 m long and  $1.0\text{mm}^2$  in cross-sectional area. It carries a current of 4.0A when a 2.0V potential difference is applied between its ends. What is the conductivity  $\sigma$ , of Nichrome?
- 7.13) A copper wire and an iron wire of equal length  $l$  and diameter  $d$  are joined and a potential difference  $V$  is applied between the ends of the composite wire. Calculate (a) the potential difference across each wire. Assume that  $l=10\text{m}$ ,  $d=2.0\text{mm}$ , and  $V=100\text{V}$ . (b) Also calculate the current density in each wire, and (c) the electric field in each wire.
- 7.14) Thermal energy is developed in a resistor at a rate of 100W when the current is 3.0A. What is the resistance in ohms?
- 7.15) How much current is being supplied by a 200V generator delivering 100kW of power?
- 7.16) An electric heater operating at full power draws a current of 8A from 110V circuit. (a) What is the resistance of the heater? (b) Assuming constant  $R$ , how much current should the heater draw in order to dissipate 750W?
- 7.17) A 500W heating unit is designed to operate from a 115V line. (a) By what percentage will its heat output drop if the line voltage drops to 110V? Assume no change in resistance. (b) Taking the variation of resistance with temperature into account, would the actual heat output drop be larger or smaller than that calculated in (a)?
- 7.18) A 1250W radiant heater is constructed to operate at 115V. (a) What will be the current in the heater? (b) What is the resistance of the heating coil?
- 
-

**LECTURES IN GENERAL PHYSICS**

# *Electrostatic*

*Principles and Applications*

Dr. Hazem Falah Sakeek

Al-Azhar University - Gaza

*Part Two*

## Chapter 8

# Direct Current Circuits

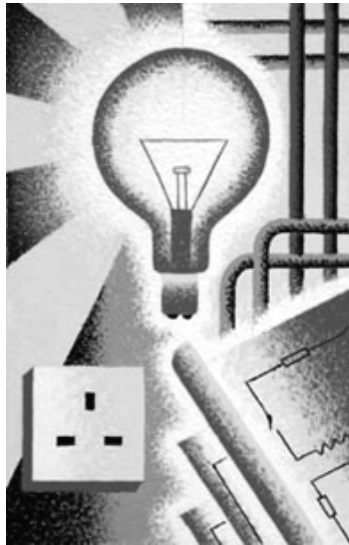

دوائر التيار المستمر

# Direct Current Circuits

## 8.1 Electromotive Force

## 8.2 Finding the current in a simple circuit

## 8.3 Kirchhoff's Rules

## 8.4 Single-Loop Circuit

## 8.5 Multi-Loop Circuit

## 8.6 RC Circuit

8.6.1 Charging a capacitor

8.6.2 Discharging a capacitor

## 8.7 Electrical Instruments

8.7.1 Ammeter and Voltmeter

8.7.2 The Wheatstone Bridge

8.7.3 The potentiometer

## 8.8 Problems



# Direct Current Circuits

## دوائر التيار المستمر



سنتعامل في هذا الفصل مع الدوائر الكهربائية التي تحتوي على بطارية ومقاومة ومكثف. سنقوم بتحليل هذه الدوائر الكهربائية معتمدين على قاعدة كيرشوف *Kirchhoff's rule* لحساب التيار الكهربائي المار في كل عنصر من عناصر الدائرة الكهربائية. وبداية سنتعرف على مفهوم القوة الدافعة الكهربائية *Electromotive force*.



## 8.1 Electromotive Force

In any electrical circuit it must exist a device to provide energy to force the charge to move in the circuit, this device could be battery or generator; in general it is called electromotive force (*emf*) symbol ( $\xi$ ). The electromotive force are able to maintain a potential difference between two points to which they are connected.

Then electromotive force (*emf*) ( $\xi$ ) is defined as the work done per unit charge.

$$\xi = \frac{dW}{dq} \quad (8.1)$$

The unit of  $\xi$  is *joule/coulomb*, which is *volt*.

The device acts as an *emf* source is drawn in the circuit as shown in the figure below, with an arrow points in the direction which the positive charge move in the external circuit. *i.e.* from the -ve terminal to the +ve terminal of the battery

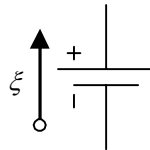

When we say that the battery is 1.5volts we mean that the *emf* of that battery is 1.5volts and if we measure the potential difference across the battery we must find it equal to 1.5volt.

A battery provide energy through a chemical reaction, this chemical reaction transfer to an electric energy which it can be used for mechanical work Also it is possible to transfer the mechanical energy to electrical energy and the electric energy can be used to charge the battery is chemical reaction. This mean that the energy can transfer in different forms in reversible process.

*Chemical* ↔ *Electrical* ↔ *Mechanical*

*See appendix (A) for more information*



## 8.2 Finding the current in a simple circuit

Consider the circuit shown in figure 8.1(a) where a battery is connected to a resistor  $R$  with connecting wires assuming the wires has no resistance.

In the real situation the battery itself has some internal resistance  $r$ , hence it is drawn as shown in the rectangle box in the diagram.

Assume a +ve charge will move from point  $a$  along the loop  $abcd$ . In the graphical representation figure 8.1(b) it shows how the potential changes as the charge moves.

When the charge cross the *emf* from point  $a$  to  $b$  the potential increases to  $a$  the value of *emf*  $\xi$ , but when it cross the internal resistance  $r$  the potential decreases by value equal  $Ir$ . Between the point  $b$  to  $c$  the potential stay constant since the wire has no resistance. From point  $c$  to  $d$  the potential decreases by  $IR$  to the same value at point  $a$ .

The potential difference across the batter between point  $a$  and  $b$  is given by

$$V_b - V_a = \xi - Ir \quad (8.2)$$

Note that the potential difference across points  $a$  and  $b$  is equal to the potential difference between points  $c$  and  $d$  *i.e.*

$$V_b - V_a = V_d - V_c = IR \quad (8.3)$$

Combining the equations

$$IR = \xi - Ir \quad (8.4)$$

Or

$$\xi = IR + Ir \quad (8.5)$$

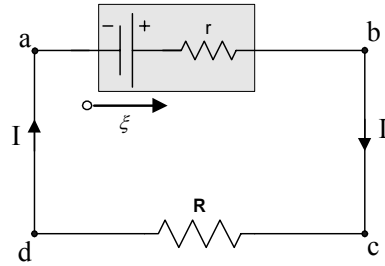

Figure 8.1(a)

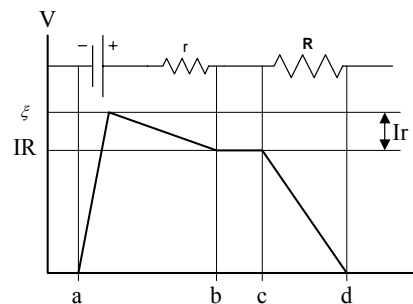

Figure 8.1(b)

Therefore the current  $I$  is

$$I = \frac{\xi}{R + r} \quad (8.6)$$

This equation shows that the current in simple circuit depends on the resistors connected in series with the battery.

We can reach to the same answer using this rule

***The algebraic sum of the changes in potential difference across each element of the circuit in a complete loop is equal to zero.***

By applying the previous rule on the circuit above starting at point  $a$  and along the loop  $abcda$

Here in the circuit we have three elements (one  $emf$  and two resistors  $r$  &  $R$ ) applying the rule we get,

$$+ \xi - Ir - IR = 0 \quad (8.7)$$

The +ve sign for  $\xi$  is because the change in potential from the left to the right across the battery the potential increases, the -ve sign for the change in potential across the resistors is due to the decrease of the potential as we move in the direction  $abcda$ .

$$\therefore I = \frac{\xi}{R + r} \quad (8.8)$$



**Example 8.1**

In figure 8.2 find the current flow in the branch if the potential difference  $V_b - V_a = 12\text{v}$ . Assume  $\xi_1 = 10\text{v}$ ,  $\xi_2 = 25\text{v}$ ,  $R_1 = 3\Omega$ , and  $R_2 = 5\Omega$ .

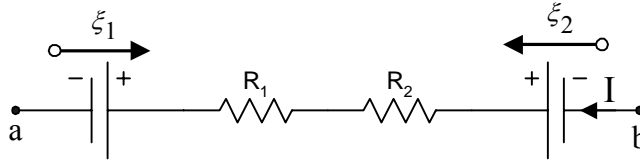

Figure 8.2



**Solution**

We must assume a direction of the current flow in the branch and suppose that is from point  $b$  to point  $a$ .

To find the current in the branch we need to add all the algebraic changes in the potential difference for the electrical element as we move from point  $a$  to point  $b$ .

$$V_b - V_a = +\xi_1 + IR_1 + IR_2 - \xi_2$$

لاحظ هنا أننا اخترنا المسار من النقطة  $a$  إلى النقطة  $b$ . وذلك معتمدين على أن فرق الجهد الكهربائي هو الشغل المبذول لتحريك شحنة من النقطة  $a$  إلى النقطة  $b$ .

Solving for  $I$

$$I = \frac{(V_b - V_a) + (\xi_2 - \xi_1)}{R_1 + R_2} = \frac{(12) + (25 - 10)}{8} = 3.375\text{A}$$



**Example 8.2**

Find the potential difference  $V_a - V_b$  for the branches shown in figure 8.3 & figure 8.4.



**Solution**

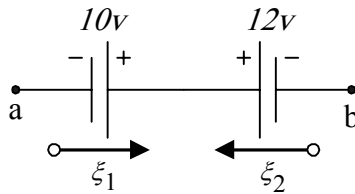

Figure 8.3

To find the potential difference  $V_a - V_b$  we should add the algebraic change in the potential difference for the two batteries as we move from point  $b$  to point  $a$ .

$$V_a - V_b = +\xi_2 - \xi_1 = 12 - 10 = 2\text{v}$$

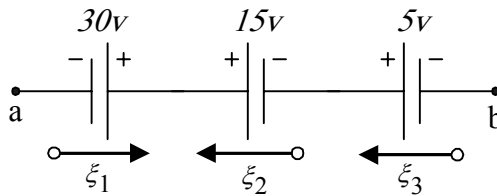

Figure 8.4

$$V_a - V_b = +\xi_3 + \xi_2 - \xi_1 = 5 + 15 - 30 = -10\text{v}$$

وهذا يعني أن النقطة  $b$  لها جهد أعلى من النقطة  $a$  وحيث أن التيار الكهربائي يسري من الجهد المرتفع إلى الجهد المنخفض لذا فإن البطارية  $\xi_3$  والبطارية  $\xi_2$  تكونان في حالة شحن بواسطة البطارية  $\xi_1$ .

### 8.3 Kirchhoff's Rules

A practical electrical circuit is usually a complicated system of many electrical elements. Kirchhoff extended Ohm's law to such systems, and gave two rules, which together enabled the current in any part of the circuit to be calculated.

#### Statements of Kirchhoff's Rules

(1) The algebraic sum of the currents entering any junction must equal the sum of the currents leaving that junction.

$$\sum_i I_i = 0 \quad \text{at the junction} \quad (8.9)$$

(2) The algebraic sum of the changes in potential difference across all of the elements around any closed circuit loop must be zero.

$$\sum_i \Delta V_i = 0 \quad \text{for the loop circuit} \quad (8.10)$$

*Note that the first Kirchhoff's rule is for the current and the second for the potential difference.*

**Applying the first rule on the junction shown below (figure 8.5)**

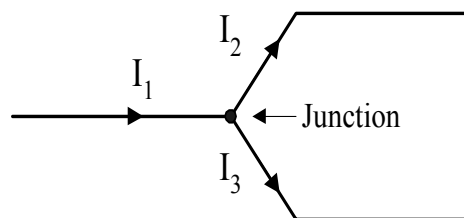

*Figure 8.5*

$$I_1 = I_2 + I_3$$



**Applying the second rule on the following cases**

(1) If a resistor is traversed in the direction of the current, the change in potential difference across the resistor is  $-IR$ .

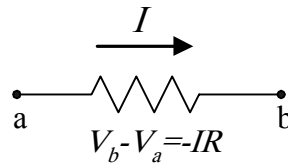

(2) If a resistor is traversed in the direction opposite the current, the change in potential difference across the resistor is  $+IR$ .

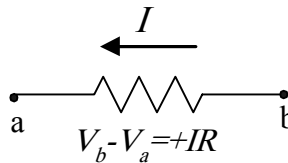

(3) If a source of *emf* is traversed in the direction of the *emf* (from - to + on the terminal), the change in potential difference is  $+\xi$ .

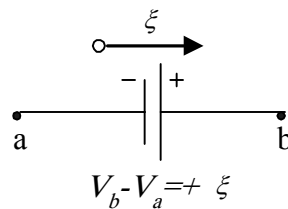

(4) If a source of *emf* is traversed in the direction opposite the *emf* (from + to - on the terminal), the change in potential difference is  $-\xi$ .

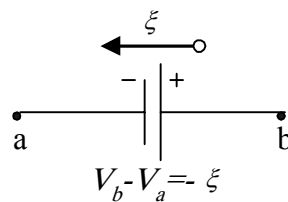

## Hints for solution of problems using Kirchhoff's rules

### لاستخدام قاعدة كيرشوف يجب اتباع الخطوات التالية:

- (1) حدد اتجاه القوة الدافعة الكهربائية  $emf$  لكل بطارية في الدائرة الكهربائية بسهم متجه من القطب السالب إلى القطب الموجب للبطارية.
- (2) حدد اتجاه التيار الكهربائي لكل عنصر من عناصر الدائرة الكهربائية مثل المقاومة بافتراض اتجاه محدد للتيار حتى تتمكن من تطبيق قاعدتي كيرشوف. فإذا كان الحل النهائي يظهر إشارة موجبة للتيار يكون الاتجاه المفترض صحيحاً، أما إذا ظهرت إشارة التيار سالبة فإن قيمة التيار صحيحة، ولكن اتجاه التيار في الاتجاه المعاكس للاتجاه المفترض.
- (3) نطبق القاعدة الأولى لكيرشوف عند العقدة الموجودة في الدائرة الكهربائية بحيث تكون إشارة التيارات الداخلة على العقدة موجبة والخارجة من العقدة سالبة.
- (4) نطبق القاعدة الثانية لكيرشوف على مسار مغلق محدد لكل فرع من أفرع الدائرة الكهربائية ونراعي التغير في فرق الجهد على كل عنصر من عناصر الدائرة الكهربائية إذا كان سالباً أو موجباً.
- (5) نحل المعادلات الرياضية التي نتجت من تطبيق الخطوتين (3) و(4) حلاً جبرياً.

## 8.4 Single-Loop Circuit

In a single-loop circuit there is no junctions and the current is the same in all elements of the circuit, therefore we use only the second Kirchhoff rule.



### Example 8.3

Two battery are connected in opposite in a circuit contains two resistors as shown in figure 8.6 the *emf* and the resistance are  $\xi_1=6\text{v}$ ,  $\xi_2=12\text{v}$ ,  $R_1=8\Omega$ , and  $R_2=10\Omega$ . (a) Find the current in the circuit. (b) What is the power dissipated in each resistor?

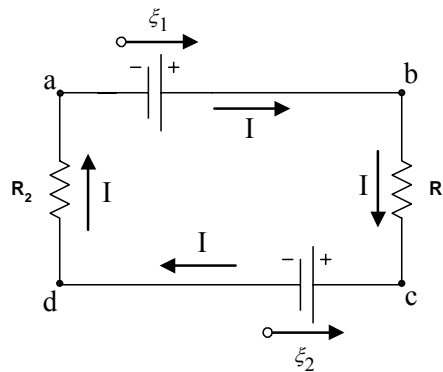

Figure 8.6



### Solution

From figure 8.6 the circuit is a single-loop circuit. We draw an arrow for each *emf* in the circuit directed from the -ve to +ve terminal of the *emf*. If we assume the current in the circuit is in the clockwise direction (*abcd*).

Applying the second Kirchhoff's rule along arbitrary loop (*abcd*) we get

$$\sum_i \Delta V_i = 0$$

Starting at point (*a*) to point (*b*) we find the direction of the loop is the same as the direction of the *emf* therefore  $\xi_1$  is +ve, and the direction of the loop from point (*b*) to point (*c*) is the same with the direction of the current then the change in potential difference is -ve and has the value  $-IR_1$ . Complete the loop with the same principle as discussed before we get;

$$+\xi_1 - IR_1 - \xi_2 + IR_2 = 0$$

Solving for the current we get

$$I = \frac{\xi_1 - \xi_2}{R_1 + R_2} = \frac{6 - 12}{8 + 10} = -\frac{1}{3} \text{ A}$$

The -ve sign of the current indicates that the correct direction of the current is opposite the assumed direction *i.e.* along the loop (*adba*)

The power dissipated in  $R_1$  and  $R_2$  is

$$P_1 = I^2 R_1 = 8/9 \text{ W}$$

$$P_2 = I^2 R_2 = 10/9 \text{ W}$$

In this example the battery  $\xi_2$  is being charged by the battery  $\xi_1$ .

---



### Example 8.4

Three resistors are connected in series with battery as shown in figure 8.7, apply second Kirchhoff's rule to (a) Find the equivalent resistance and (b) find the potential difference between the points *a* and *b*.

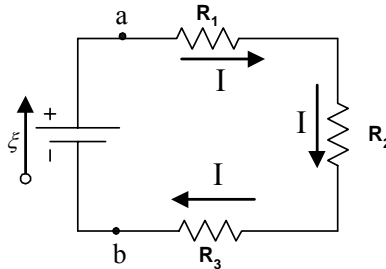

Figure 8.7



### Solution

Applying second Kirchhoff's rule in clockwise direction we get

$$-IR_1 - IR_2 - IR_3 + \xi = 0$$

or

$$I = \frac{\xi}{R_1 + R_2 + R_3}$$

$$\therefore I = \frac{\xi}{R}$$

therefore,

$$R = R_1 + R_2 + R_3$$

This is the same result obtained in section 7.1.1

To find the potential difference between points a and b  $V_{ab}$  ( $=V_a - V_b$ ) we use the second Kirchhoff's rule along a direction starting from point (b) and finish at point (a) through the resistors. We get

$$V_b + IR = V_a$$

Where  $R$  is the equivalent resistance for  $R_1$ ,  $R_2$  and  $R_3$

$$V_{ab} = V_a - V_b = + IR$$

The +ve sign for the answer means that  $V_a > V_b$

Substitute for the current  $I$  using the equation

$$I = \frac{\xi}{R}$$

we get

$$V_{ab} = \xi$$

This means that the potential difference between points  $a$  and  $b$  is equal to the *emf* in the circuit (when the internal resistance of the battery is neglected).



### Example 8.5

In the circuit shown in figure 8.8 let  $\xi_1$  and  $\xi_2$  be 2v and 4v, respectively;  $r_1$ ,  $r_2$  and  $R$  be  $1\Omega$ ,  $2\Omega$ , and  $5\Omega$ , respectively. (a) What is

the current in the circuit? (b) What is the potential difference  $V_a - V_b$  and  $V_a - V_c$ ?

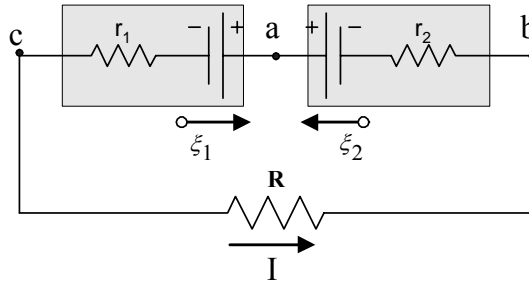

Figure 8.8



**Solution**

Since the emf  $\xi_2$  is larger than  $\xi_1$  then  $\xi_2$  will control the direction of the current in the circuit. Hence we assume the current direction is counterclockwise as shown in figure 8.8. Applying the second Kirchhoff's rule in a loop clockwise starting at point  $a$  we get

$$-\xi_2 + Ir_2 + IR + Ir_1 + \xi_1 = 0$$

Solving the equation for the current we get

$$I = \frac{\xi_2 - \xi_1}{R + r_1 + r_2} = \frac{4 - 2}{5 + 1 + 2} = +0.25A$$

The +ve sign for the current indicates that the current direction is correct. If we choose the opposite direction for the current we would get as a result -0.25A.

The potential difference  $V_a - V_b$  we apply second Kirchhoff's rule starting at point  $b$  to finishing at point  $a$ .

$$V_a - V_b = -Ir_2 + \xi_2 = (-0.25 \times 2) + 4 = +3.5v$$

Note that same result you would obtain if you apply the second Kirchhoff's rule to the other direction (the direction goes through  $R$ ,  $r_1$ , and  $\xi_1$ )

The potential difference  $V_a - V_c$  we apply second Kirchhoff's rule starting at point  $c$  to finishing at point  $a$ .

$$V_a - V_b = +\xi_1 + Ir_1 = +2 + (-0.25 \times 1) = +2.25 \text{v}$$

Note that same result you would obtain if you apply the second Kirchhoff's rule to the other direction (the direction goes through  $R$ ,  $r_2$ , and  $\xi_2$ )

---

---

## 8.5 Multi-Loop Circuit

Some circuits involving more than one current loop, such as the one shown in figure 8.9. Here we have a circuit with three loops: a left inside loop, a right inside loop, and an outside loop. There is no way to reduce this multi-loop circuit into one involving a single battery and resistor.

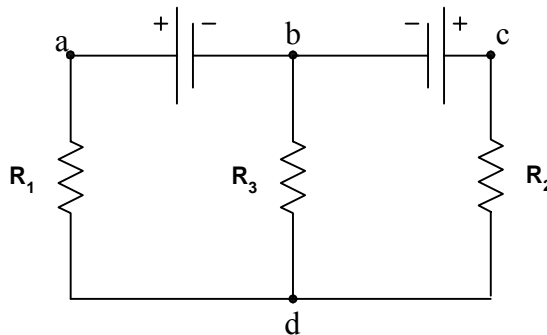

Figure 8.9

In the circuit shown above there are two junctions *b* and *d* and three branches connecting these junctions. These branches are *bad*, *bcd*, and *bd*. The problem here is to find the currents in each branch.

A general method for solving multi-loop circuit problem is to apply Kirchhoff's rules.

**You should always follow these steps:**

(1) Assign the direction for the *emf* from the -ve to the +ve terminal of the battery.

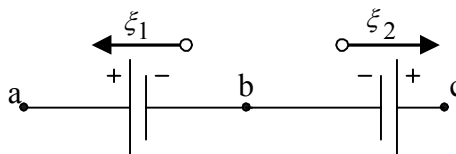

Figure 8.10

(2) Assign the direction of the currents in each branch assuming arbitrary direction.



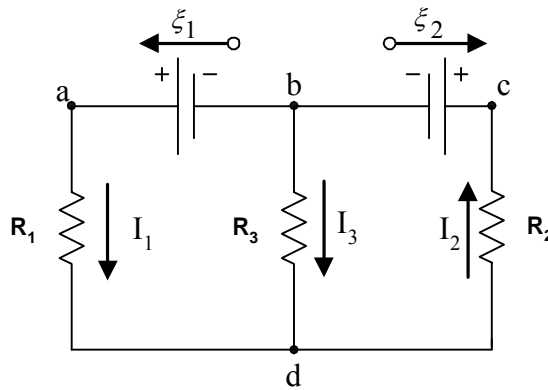

Figure 8.11

After solving the equations the +ve sign of the current means that the assumed direction is correct, and the -ve sign for the current means that the opposite direction is the correct one.

(3) Chose one junction to apply the first Kirchhoff's rule.

$$\sum_i I_i = 0$$

At junction  $d$  current  $I_1$  and  $I_3$  is approaching the junction and  $I_2$  leaving the junction therefore we get this equation

$$I_1 + I_3 - I_2 = 0 \quad (1)$$

(4) For the three branches circuit assume there are two single-loop circuits and apply the second Kirchhoff's rule on each loop.

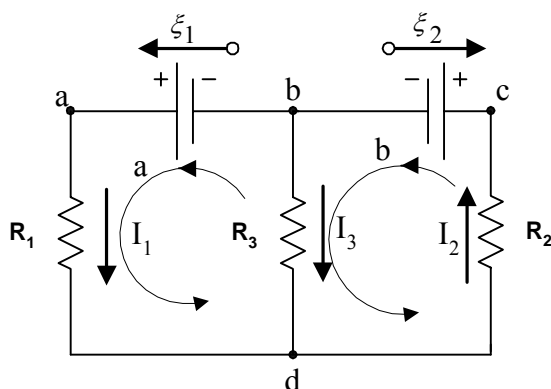

Figure 8.12

For loop a on the left side starting at point b we get

$$+\xi_1 - I_1R_1 + I_3R_3 = 0 \quad (2)$$

For loop b on the left side starting at point b we get

$$-I_3R_3 - I_2R_2 - \xi_2 = 0 \quad (3)$$

Equations (1), (2), and (3) can be solved to find the unknowns currents  $I_1$ ,  $I_2$ , and  $I_3$ .

**The current can be either positive or negative, depending on the relative sizes of the *emf* and of the resistances.**



**Example 8.6**

In the circuit shown in figure 8.13, find the unknown current  $I$ , resistance  $R$ , and  $emf \xi$ .

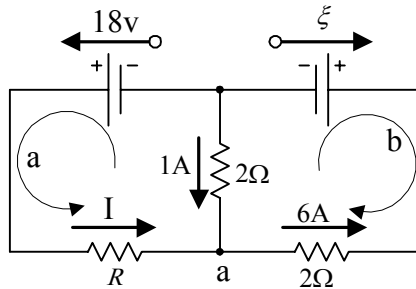

Figure 8.13



**Solution**

At junction a we get this equation

$$I + 1 - 6 = 0$$

Therefore the current

$$I = 5A$$

To determine  $R$  we apply the second Kirchhoff's rule on the loop (a), we get

$$18 - 5R + 1 \times 2 = 0$$

$$R = 4\Omega$$

To determine  $\xi$  we apply the second Kirchhoff's rule on the loop (a), we get

$$\xi + 6 \times 2 + 1 \times 2 = 0$$

$$\xi = -14v$$



**Example 8.7**

In the circuit shown in figure 8.14, (a) find the current in the  $2\Omega$  resistor, (b) the potential difference between points  $a$  and  $b$ .

(Use the current as labeled in the figure 8.14).

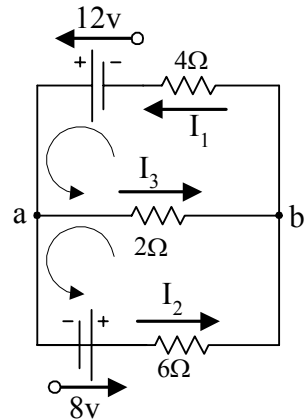

Figure 8.14



**Solution**

At junction  $a$  we get

$$I_1 = I_2 + I_3 \quad (1)$$

For the top loop

$$12 - 2 \times I_3 - 4 \times I_1 = 0 \quad (2)$$

For the bottom loop

$$8 - 6 \times I_2 + 2 \times I_3 = 0 \quad (3)$$

From equation (2)

$$I_1 = 3 - 1/2 I_3$$

From equation (3)

$$I_2 = 4/3 - 1/3 I_3$$

Substituting these values in equation (1), we get

$$I_3 = 0.909\text{A} \text{ the current in the resistor } 2\Omega$$

The potential difference between points  $a$  and  $b$

$$V_a - V_b = I_3 \times R = 0.909 \times 2 = 1.82\text{v} \quad V_a > V_b$$



### Example 8.8

In the circuit shown in figure 8.15, (a) find the current  $I_1$ ,  $I_2$ , and  $I_3$ , (b) the potential difference between points  $a$  and  $b$ . Use these values,  $\xi_1=10\text{v}$ ,  $\xi_2=6\text{v}$ ,  $\xi_3=4\text{v}$ ,  $R_1=6\Omega$ ,  $R_2=2\Omega$ ,  $R_3=1\Omega$ , and  $R_4=4\Omega$ .

(Use the current as labeled in the figure below).

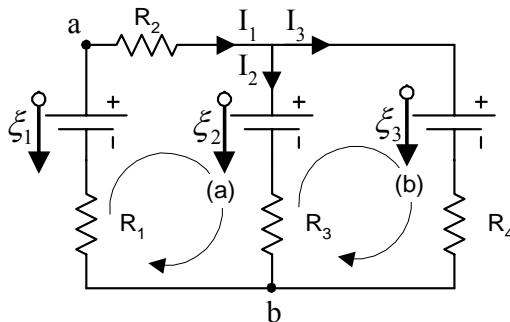

Figure 8.15



### Solution

For the junction at the top we get

$$I_1 + I_2 - I_3 = 0 \quad (1)$$

For loop a on the left side we get

$$\begin{aligned} +\xi_1 - I_1R_2 - \xi_2 + I_2R_3 - I_1R_1 &= 0 \\ +10 - 2I_1 - 6 + I_2 - 6I_1 &= 0 \\ +4 - 8I_1 + I_2 &= 0 \end{aligned} \quad (2)$$

For loop b on the right side we get

$$\begin{aligned} -I_2R_3 + \xi_2 - \xi_2 + I_3R_4 &= 0 \\ -I_2 + 6 - 4 - 4I_3 &= 0 \\ +2 - I_2 - 4I_3 &= 0 \end{aligned} \quad (3)$$

From equation (2)

$$I_1 = \frac{4 + I_2}{8} \quad (4)$$

From equation (3)

$$I_3 = \frac{2 - I_2}{4} \quad (5)$$

Substitute in equation (1) from equations (4)&(5) we get

$$\frac{4 + I_2}{8} + I_2 - \frac{2 - I_2}{4} = 0$$

$$I_2 = 0$$

From equation (4)

$$I_1 = 0.5\text{A}$$

From equation (4)

$$I_3 = 0.5\text{A}$$

The potential difference between points a and b we use the loop (a)

$$V_b - V_a = -\xi_1 + I_1 R_2$$

$$V_b - V_a = -\xi_1 + I_1 R_2$$

$$V_b - V_a = 10 - 0.5 \times 6 = -7\text{V} \quad (V_b < V_a)$$



**Example 8.9**

Consider the circuit shown in Figure 8.16. Find (a) the current in the 20.0 Ω resistor and (b) the potential difference between points a and b.

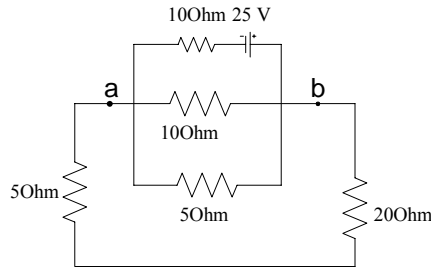

Figure 8.16



**Solution**

Turn the diagram in figure 8.16 on its side, we find that the 20Ω and 5Ω resistors are in series, so the first reduction is as shown in (b). In addition, since the 10Ω, 5Ω, and 25Ω resistors are then in parallel, we can solve for their equivalent resistance as

$$R_{eq} = \frac{1}{\left(\frac{1}{10} + \frac{1}{5} + \frac{1}{25}\right)} = 2.94\Omega$$

This is shown in figure (c), which in turn reduces to the circuit shown in (d).

Next we work backwards through the diagrams, applying  $I=V/R$  and  $V=IR$ . The 12.94Ω resistor is connected across 25V, so the current through the voltage source in every diagram is

$$I = \frac{V}{R} = \frac{25}{12.94} = 1.93A$$

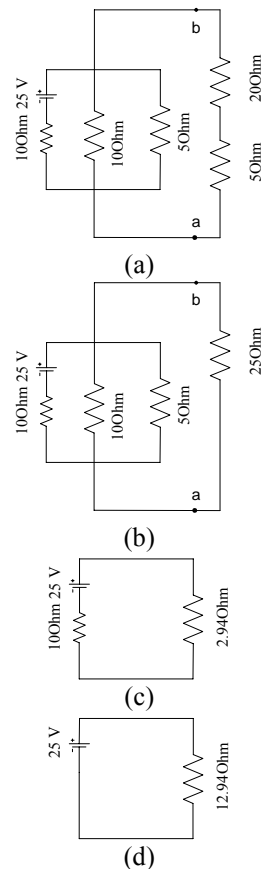

## Direct Current Circuits

---

In figure (c), the current 1.93A goes through the  $2.94\Omega$  equivalent resistor to give a voltage drop of:

$$V = IR = (1.93)(2.94) = 5.68\text{V}$$

From figure (b), we see that this voltage drop is the same across  $V_{ab}$ , the  $10\Omega$  resistor, and the  $5\Omega$  resistor.

Therefore

$$V_{ab} = 5.68\text{V}$$

Since the current through the  $20\Omega$  resistor is also the current through the  $25\Omega$

$$I = V_{ab}/R_{ab} = 5.68/25 = 0.227\text{A}$$

---

---



### Example 8.10

Determine the current in each of the branches of the circuit shown in figure 8.17.

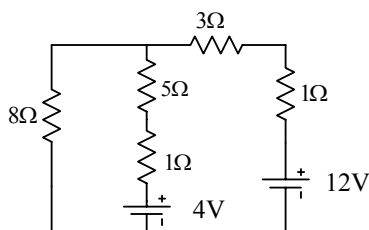

Figure 8.17



### Solution

First we should define an arbitrary direction for the current as shown in the figure below.

$$I_3 = I_1 + I_2 \quad (1)$$

By the voltage rule the left-hand loop

$$+I_1(8\Omega) - I_2(5\Omega) - I_2(1\Omega) - 4\text{V} = 0 \quad (2)$$

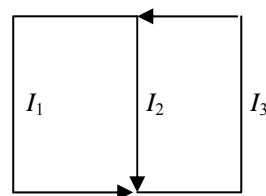



For the right-hand loop

$$4V + I_2(5\Omega + 1\Omega) + I_3(4\Omega) - 12V = 0 \quad (3)$$

Substitute for  $I_3$  from eqn. (1) into eqns. (2)&(3)

$$8I_1 - 6I_2 - 4 = 0 \quad (4)$$

$$4 + 6I_2 + 4(I_1 + I_2) - 12 = 0 \quad (5)$$

Solving eqn. (4) for  $I_2$

$$I_2 = \frac{8I_1 - 4}{6}$$

Rearranging eqn. (5) we get

$$I_1 + \frac{10}{4}I_2 = \frac{8}{4}$$

Substitute for  $I_2$  we get

$$I_1 + 3.33I_1 - 1.67 = 2$$

Then,

$$I_1 = 0.846\text{A}$$

$$I_2 = 0.462\text{A}$$

$$I_3 = 1.31\text{A}$$

## 8.6 RC Circuit

In the previous section we studied either circuits with resistors only or with capacitors only, now we will deal with circuits contains both the resistors and capacitors together, these circuits are time dependent circuit where the current in the is varying with time.

In the circuit shown in figure 8.18 we have connected an *emf* with resistor  $R$  and uncharged capacitor  $C$  using a switch  $S$ .

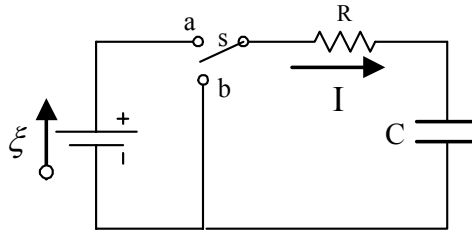

Figure 8.18

### 8.6.1 Charging a capacitor

When the switch  $S$  is connected to point (a) the battery will force charges to move to the capacitor this called *charging* process of the capacitor. Note that the current will not flow through the capacitor since there is no way for the charge to jump from one plate to the other. However a positive charge will accumulate on the plate connected with the positive terminal of the battery. The same number of a negative charge will accumulate on the other plate.

The current must stop after the capacitor will become fully charged and its potential difference equals the *emf*.

نلاحظ هنا في هذه الحالة أن التيار يكون ذا قيمة عظمى عند غلق المفتاح وبمرور الزمن يتناقص التيار إلي أن يصل إلى الصفر. وعندها يكون شحن المكثف قد اكتمل.

To analyze this circuit let's assume that in time  $dt$  a charge  $dq$  moves through the resistor and the capacitor. Apply the first Kirchhoff's rule in a direction from the battery to the resistor to the capacitor we get,

$$\xi - IR - \frac{q}{C} = 0 \quad (8.11)$$

Where  $IR$  is the potential difference across the resistor and  $q/C$  is the potential difference across the capacitor.

The current  $I$  and the charge  $q$  are varying with time. Substitute for

$$I = \frac{dq}{dt} \quad (8.12)$$

$$\zeta - R \frac{dq}{dt} - \frac{q}{C} = 0 \quad (8.13)$$

By solving the differential equation to find the  $q$  as a function of time we get,

$$q = C\zeta(1 - e^{-t/RC}) \quad (8.14)$$

The quantity  $C\zeta$  is the maximum charge  $Q$  in the capacitor.

$$q = Q(1 - e^{-t/RC}) \quad (8.15)$$

The current  $I$  is

$$I = \frac{dq}{dt} = \frac{\zeta}{R} e^{-t/RC} \quad (8.16)$$

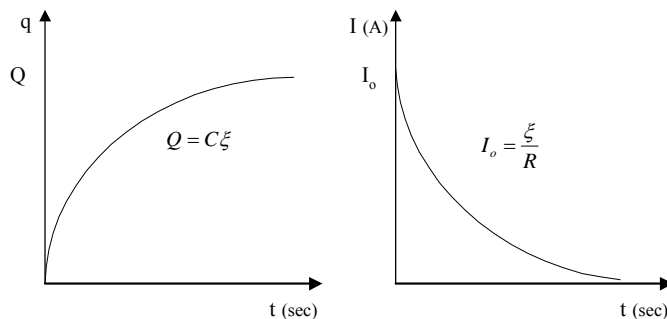

**Figure 8.19**

*Plots of the charge  $Q$  and the current  $I$  as a function of time in the charging process*

Note that the quantity  $RC$  in the equation has a unit of time (sec). Therefore it is called the *time constant* of the circuit.

Unit of  $RC$  is  $Ohm \cdot Farad = Sec$

$$Ohm.Farad = Ohm. \frac{Coulomb}{Volt} = Ohm. \frac{Amp.Sec}{Volt} = \frac{Volt.Sec}{Volt} = Sec$$

### 8.6.2 Discharging a capacitor

When the switch  $S$  is connected to point (b) the battery is disconnected and now the charged capacitor plays the role of *emf*. Therefore the capacitor will force a charge  $q$  to move through the resistor  $R$  this called *discharging* process of the capacitor.

Apply the first Kirchhoff's rule in a direction from the resistor to the capacitor we get,

$$-IR - \frac{q}{C} = 0 \quad (8.17)$$

The current  $I$  and the charge  $q$  are varying with time. Substitute for

$$I = \frac{dq}{dt} \quad (8.18)$$

$$R \frac{dq}{dt} + \frac{q}{C} = 0 \quad (8.19)$$

By solving the differential equation to find the  $q$  as a function of time we get,

$$q = Qe^{-t/RC} \quad (8.20)$$

The current  $I$  during the discharging process is

$$I = \frac{dq}{dt} = -\frac{Q}{RC} e^{-t/RC} \quad (8.21)$$

The -ve sign indicates that the direction of the current in the discharging process is in the opposite direction of the charging process.

The quantity  $Q/RC$  is equal to the initial current  $I_0$  (i.e. when  $t=0$ )

$$I = I_0 e^{-t/RC} \quad (8.22)$$

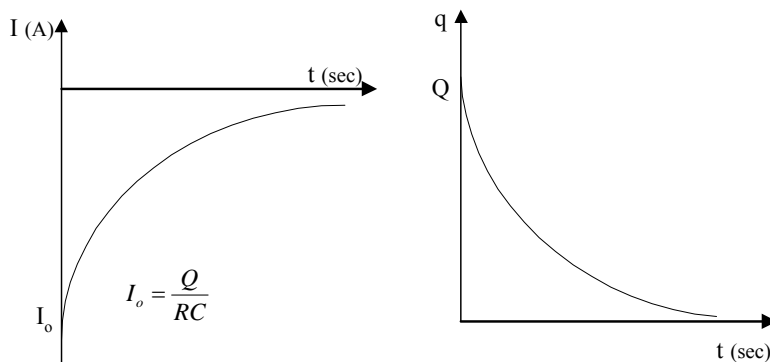

Figure 8.20

*Plots of the charge  $Q$  and the current  $I$  as a function of time in the discharging process*

**In the end we found that charging and discharging process of the capacitor is exponentially depends on the time constant ( $RC$ ).**



### Example 8.11

Consider an  $RC$  circuit in which the capacitor is being charged by a battery connected in the circuit. In five time constants, what percentage of the final charge is on the capacitor?



### Solution

From equation (8.20)

$$q = Q(1 - e^{-t/RC})$$

$$t = 5RC$$

$$\frac{q}{Q} = 1 - e^{-t/RC}$$

$$\frac{q}{Q} = 1 - e^{-5RC/RC} = 1 - e^{-5} = 99.3\%$$



### Example 8.12

In figure 8.21 (a) find the time constant of the circuit and the charge on the capacitor after the switch is closed. (b) find the current in the resistor  $R$  at a time 10sec after the switch is closed. Assume  $R=1 \times 10^6 \Omega$ ,  $emf=30V$  and  $C=5 \times 10^{-6} \mu F$ .

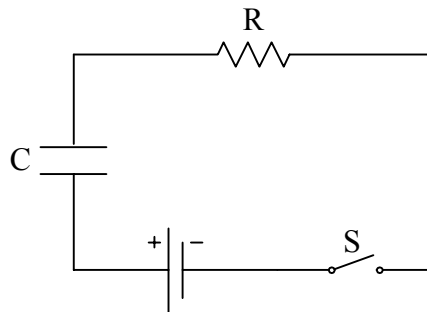

Figure 8.21



**Solution**

(a) The time constant =  $RC = (1 \times 10^{-6})(5 \times 10^{-6}) = 5 \text{ sec}$

The charge on the capacitor =  $Q = C\xi = (5 \times 10^{-6})(30) = 150 \mu\text{C}$

(b) The current in charging of the capacitor is given by

$$I = \frac{\xi}{R} e^{-t/RC}$$

$$I = \frac{30}{1 \times 10^6} e^{-\left(\frac{10}{(1 \times 10^6)(5 \times 10^{-6})}\right)} = 4.06 \times 10^{-6} \text{ A}$$



**Example 8.13**

Determine the potential difference  $V_b - V_a$  for the circuit shown in figure 8.22



**Solution**

The current is zero in the middle branch since there is discontinuity at the points  $a$  and  $b$ . Applying the second Kirchhoff's rule for the outside loop we get,

$$+12 - 10I - 5I - 8 - 1/2I - 1/2I = 0$$

$$+4 - 16I = 0$$

$$I = 4\text{A}$$

The potential difference  $V_b - V_a$  is found by applying the second Kirchhoff's rule at point  $a$  and move across the upper branch to reach point  $b$  we get,

$$V_b - V_a = +10I - 12 + 1/2I + 4$$

$$V_b - V_a = -8 + 10.5I = -8 + (10.5 \times 4) = 34 \text{ volt}$$

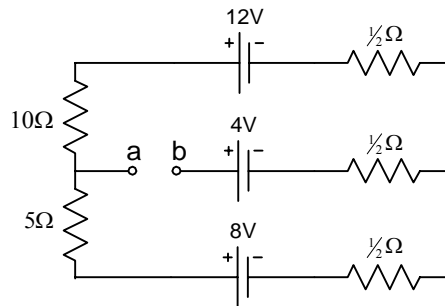

Figure 8.22



**Example 8.14**

The circuit has been connected as shown in figure 8.23 for a long time. (a) What is the voltage across the capacitor? (b) If the battery is disconnected, how long does it take for the capacitor to discharge to 1/10 of its initial voltage? The capacitance  $C=1\mu\text{F}$ .

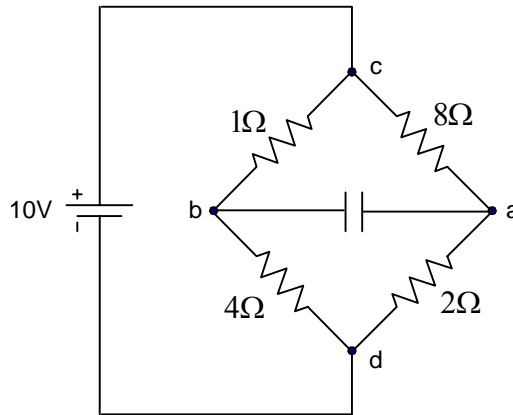

Figure 8.23



**Solution**

After long time the capacitor would be fully charged and the current in the branch  $ab$  equal zero.

The resistors in the left hand ( $1\Omega$ , and  $4\Omega$ ) are connected in series and assume the current in this branch  $cbd$  is  $I_1$ . The resistors in the right hand ( $8\Omega$ , and  $2\Omega$ ) are connected in series and assume the current in this branch  $cad$  is  $I_2$ .

The potential difference across the points  $c$  and  $d$  is the same as the  $emf = 10\text{volt}$ . Therefore,

$$I_1 = \frac{10}{1+4} = 2A$$

$$I_2 = \frac{10}{2+8} = 1A$$

The total current,

$$I = I_1 + I_2 = 3A$$



The potential difference across the capacitor  $V_b - V_a$  is

$$V_b - V_a = 8I_2 - 1I_1 = 8 \times 1 - 1 \times 2 = 6 \text{ volt}$$

To find the answer of (b) we need to find the equivalent resistance,

$$\frac{1}{R} = \frac{1}{R_1} + \frac{1}{R_2} = \frac{1}{5} + \frac{1}{10} = \frac{3}{10}$$

Where  $R_1$  is the equivalent resistance for ( $1\Omega$ , and  $4\Omega$ ), and  $R_2$  is the equivalent resistance for ( $2\Omega$ , and  $8\Omega$ )

$$R = 3.3\Omega$$

From equation 8.17

$$q = Qe^{-t/RC}$$

Divide by the capacitance  $C$ , therefore

$$\frac{q}{C} = \frac{Q}{C} e^{-t/RC}$$

$$v = V e^{-t/RC}$$

$$\therefore \frac{v}{V} = e^{-t/RC}$$

The time for the capacitor to discharge to 1/10 of its initial voltage

$$\frac{1}{10} = e^{-t/RC}$$

$$\ln 1 - \ln 10 = -t/RC$$

$$t = \ln 10 \times R \times C$$

$$t = 7.7\mu\text{s}$$

## 8.7 Electrical Instruments

### 8.7.1 Ammeter and Voltmeter

A device called *ammeter* is used to measure the current flow in a circuit, the ammeter must be connected in *series* in the circuit so that the current to be measured actually passes through the meter. In order that the ammeter will not affect the current in the circuit it must have *very small* resistance.

A device called *voltmeter* is used to measure the potential difference between two points, and its terminals must be connected to these points in *parallel*.

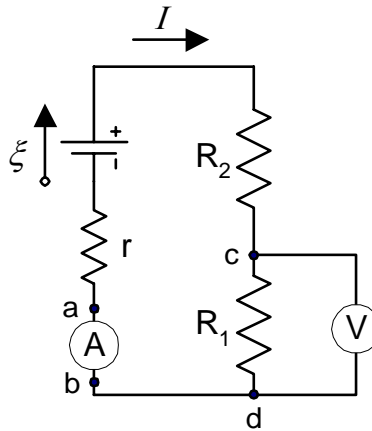

Figure 8.24

In figure 8.24 shows an ammeter (A) measure the current  $I$  in the circuit. Voltmeter (V), measure the potential difference across the resistor  $R_1$ , ( $V_c - V_d$ ). In order that the voltmeter will not affect the current in the circuit it must have *very large* resistance.

Note that the ammeter is connected in series in the circuit and the voltmeter is connected in parallel with the points to measure the potential difference across them.

### 8.7.2 The Wheatstone Bridge

This is a circuit consist of four resistors, emf, and galvanometer. The Wheatstone bridge circuit is used to measure unknown resistance. In figure 8.25 show three resistors  $R_1$ ,  $R_2$ , and  $R_3$  are known with  $R_1$  is a variable resistance and resistor  $R_x$  is the unknown one.

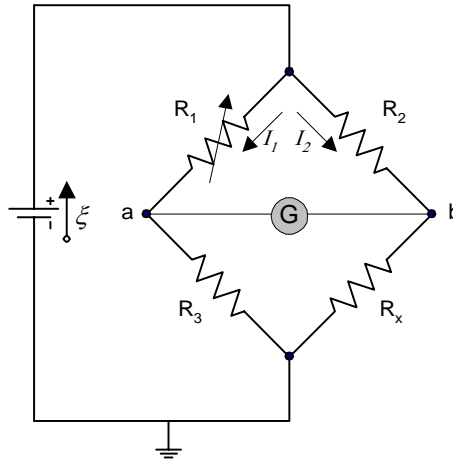

Figure 8.25

To find the resistance  $R_x$  the bridge is balanced by adjusting the variable resistance  $R_1$  until the current between  $a$  and  $b$  is zero and the galvanometer reads zero. At this condition the voltage across  $R_1$  is equal the voltage across  $R_2$  and the same for  $R_3$  and  $R_x$ . Therefore,

$$I_1 R_1 = I_2 R_2$$

$$I_1 R_2 = I_2 R_x$$

Dividing the to equation and solving for  $R_x$  we get,

$$R_x = \frac{R_2 R_3}{R_1} \quad (8.23)$$

This shows how unknown resistor can be determined using the Wheatstone bridge.

### 8.7.3 The potentiometer

This circuit is used to measure potential differences by comparison with a standard voltage source. The circuit is shown in figure 8.26 where the working *emf* is  $\xi_w$  and the unknown *emf* is  $\xi_x$ . The current flow in the circuit is  $I$  in the left branch and  $I_x$  is the current in the right branch and  $I - I_x$  is the current flow in the variable resistor. Apply second Kirchhoff's rule on the right branch *abcd* we get,

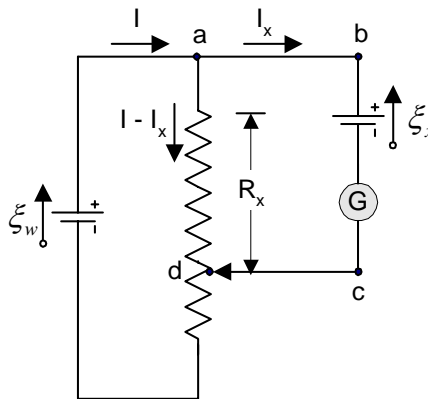

Figure 8.26

$$-(I - I_x)R_x + \xi_x = 0$$

When the variable resistance adjusted until the galvanometer reads zero, this mean that  $I_x = 0$ .

$$\xi_x = IR_x$$

In the next step the *emf*  $\xi_x$  is replaced with standard *emf*  $\xi_s$ , and adjusted the resistance until the galvanometer reads zero, therefore,

$$\xi_s = IR_x$$

Where the current  $I$  remains the same, divide the two equations we get,

$$\xi_x = \frac{R_x}{R_s} \xi_s \quad (8.24)$$

This shows how unknown *emf* can be determined using known *emf*.



## 8.8 Problems

---

- 8.1) A battery with an *emf* of 12V and internal resistance of  $0.9\Omega$  is connected across a load resistor  $R$ . If the current in the circuit is 1.4A, what is the value of  $R$ ?
- 8.2) What power is dissipated in the internal resistance of the battery in the circuit described in Problem 8.1?
- 8.3) (a) What is the current in a  $5.6\Omega$  resistor connected to a battery with an  $0.2\Omega$  internal resistance if the terminal voltage of the battery is 10V? (b) What is the *emf* of the battery?
- 8.4) If the *emf* of a battery is 15V and a current of 60A is measured when the battery is shorted, what is the internal resistance of the battery?
- 8.5) The current in a loop circuit that has a resistance of  $R_1$  is 2A. The current is reduced to 1.6A when an additional resistor  $R_2=3\Omega$  is added in series with  $R_1$ . What is the value of  $R_1$ ?
- 8.6) A battery has an *emf* of 15V. The terminal voltage of the battery is 11.6V when it is delivering 20W of power to an external load resistor  $R$ . (a) What is the value of  $R$ ? (b) What is the internal resistance of the battery?
- 8.7) A certain battery has an open-circuit voltage of 42V. A load resistance of  $12\Omega$  reduces the terminal voltage to 35V. What is the value of the internal resistance of the battery?
- 8.8) Two circuit elements with fixed resistances  $R_1$  and  $R_2$  are connected in *series* with a 6V battery and a switch. The battery has an internal resistance of  $5\Omega$ ,  $R_1=32\Omega$ , and  $R_2=56\Omega$ . (a) What is the current through  $R_1$  when the switch is closed? (b) What is the voltage across  $R_2$  when the switch is closed?
- 8.9) The current in a simple series circuit is 5.0A. When an additional resistance of  $2.0\Omega$  is inserted, the current drops to 4.0 A. What was the resistance of the original circuit?
- 8.10) Three resistors ( $10\Omega$ ,  $20\Omega$ , and  $30\Omega$ ) are connected in parallel. The total current through this network is 5A. (a) What is the voltage drop across the network (b) What is the current in each resistor?

- 8.11) (a) Find the equivalent resistance between points a and b in Figure 8.27. (b) A potential difference of 34V is applied between points a and b in Figure 28.28. Calculate the current in each resistor.

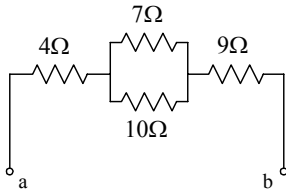

Figure 8.27

- 8.12) Evaluate the effective resistance of the network of identical resistors, each having resistance  $R$ , shown in figure 8.28.

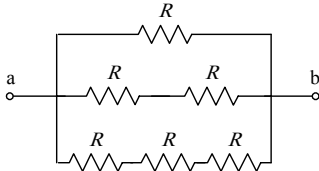

Figure 8.28

- 8.13) Calculate the power dissipated in each resistor in the circuit of figure 8.29.

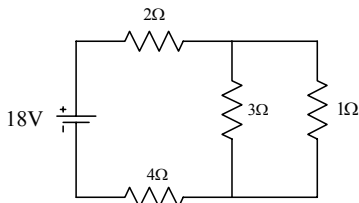

Figure 8.29

- 8.14) Consider the circuit shown in Figure 8.30. Find (a) the current in the  $20\Omega$  resistor and (b) the potential difference between points a and b.

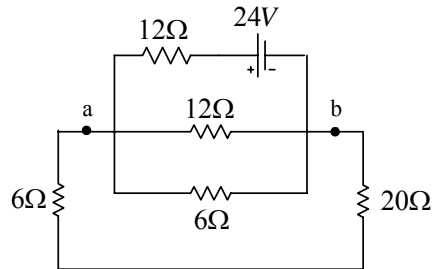

Figure 8.30

- 8.15) (a) In Figure 8.31 what value must  $R$  have if the current in the circuit is to be  $0.0010\text{A}$ ? Take  $\xi_1=2.0\text{V}$ ,  $\xi_2=3.0\text{V}$ , and  $r_1=r_2=3.0\Omega$ . (b) What is the rate of thermal energy transfer in  $R$ ?

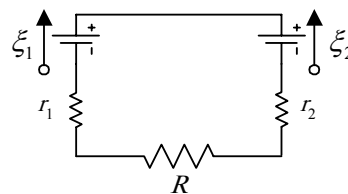

Figure 8.31

- 8.16) In Figure 8.32 (a) calculate the potential difference between a and c by considering a path that contains  $R$  and  $\xi_2$ .

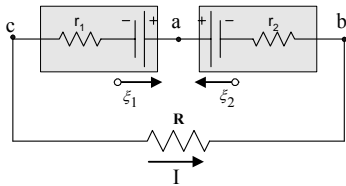

Figure 8.32

8.17) In Figure 8.33 find the current in each resistor and the potential difference between  $a$  and  $b$ . Put  $\xi_1=6.0\text{V}$ ,  $\xi_2=5.0\text{V}$ ,  $\xi_3=4.0\text{V}$ ,  $R_1=100\Omega$  and  $R_2=50\Omega$ .

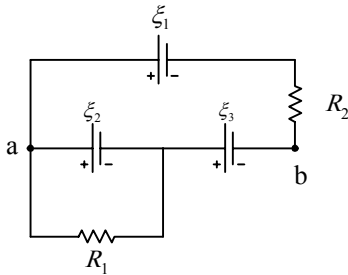

Figure 8.33

8.18) (a) Find the three currents in Figure 8.34. (b) Find  $V_{ab}$ . Assume that  $R_1=1.0\Omega$ ,  $R_2=2.0\Omega$ ,  $\xi_1=2.0\text{V}$ , and  $\xi_2=\xi_3=4.0\text{V}$ .

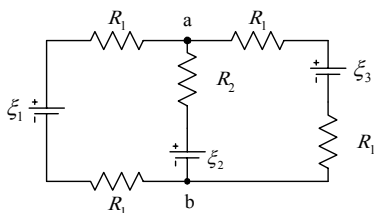

Figure 8.34

8.19) (a) Find the potential difference between points  $a$  and  $b$  in the circuit in Figure 8.35. (b) Find the currents  $I_1$ ,  $I_2$ , and  $I_3$  in the circuit.

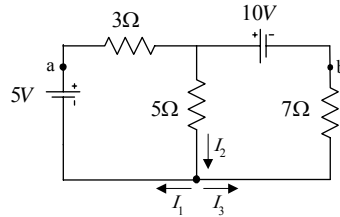

Figure 8.35

8.20) Determine the current in each of the branches of the circuit shown in figure 8.36.

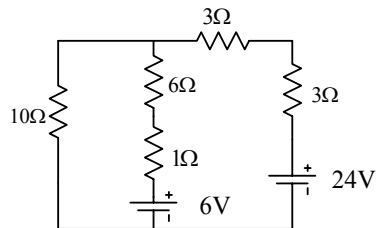

Figure 8.36

8.21) Calculate the power dissipated in each resistor in the circuit shown in figure 8.37.

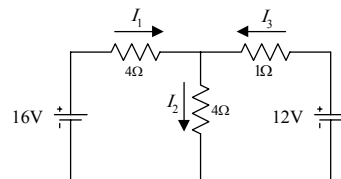

Figure 8.37

## Direct Current Circuits

---

8.22) Consider a series  $RC$  circuit for which  $R=1\text{M}\Omega$ ,  $C=5\mu\text{F}$ , and  $\xi=30\text{V}$ . Find (a) the time constant of the circuit and (b) the maximum charge on the capacitor after the switch is closed. (c) If the switch in the  $RC$  circuit is closed at  $t=0$ . Find the current in the resistor  $R$  at a time  $10\text{s}$  after the switch is closed.

take for the capacitor to become fully charged?

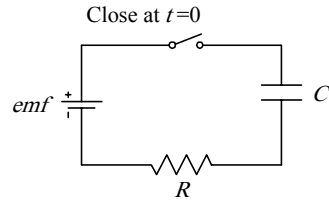

*Figure 8.38*

8.23) At  $t=0$ , an unchanged capacitor of capacitance  $C$  is connected through a resistance  $R$  to a battery of constant emf (Figure 8.38). (a) How long does it take for the capacitor to reach one half of its final charge? (b) How long does it

8.24) A  $4\text{M}\Omega$  resistor and a  $3\mu\text{F}$  capacitor are connected in series with a  $12\text{V}$  power supply. (a) What is the time constant for the circuit? (b) Express the current in the circuit and the charge on the capacitor as a function of time.



# Multiple Choice Questions

## Part 2 Applications of Electrostatic

Capacitors and Capacitance  
Current and Resistance  
Direct Current Circuits



Attempt the following question after the  
completion of part 2

### Multiple choice question for part 2

---

[1] (a) How much charge is on a plate of a  $4.00\mu\text{F}$  capacitor when it is connected to a  $12.0\text{ V}$  battery? (b) If this same capacitor is connected to a  $1.50\text{ V}$  battery, what charge is stored?

- a. (a)  $3.00\ \mu\text{C}$ ; (b)  $2.67\ \mu\text{C}$
- b. (a)  $3.00\ \mu\text{C}$ ; (b)  $0.375\ \mu\text{C}$
- c. (a)  $0.333\ \mu\text{C}$ ; (b)  $2.67\ \mu\text{C}$
- d. (a)  $48.00\ \mu\text{C}$ ; (b)  $6.00\ \mu\text{C}$

---

[2] Calculate the equivalent capacitance between points a and b in Figure 1.

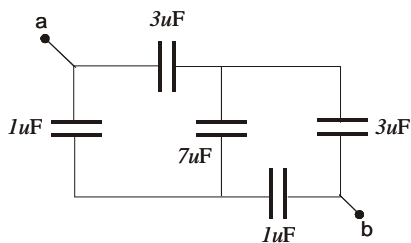

*Figure 1*

Note that this is not a simple series or parallel combination. (Hint: Assume a potential difference  $\Delta V$  between points a and b. Write expressions for  $\Delta V_{ab}$  in terms of the charges and capacitances for the various possible pathways from a to b, and require conservation of charge for those capacitor plates that are connected to each other.)

- a.  $4.68\ \mu\text{F}$
- b.  $15.0\ \mu\text{F}$
- c.  $0.356\ \mu\text{F}$
- d.  $200\ \mu\text{F}$

---

[3] Two capacitors  $C_1 = 27.0\ \mu\text{F}$  and  $C_2 = 7.00\ \mu\text{F}$ , are connected in parallel and charged with a  $90.0\text{ V}$  power supply. (a) Calculate the total energy stored in the two capacitors. (b) What potential difference would be required across the same two capacitors connected in series in order that the combinations store the same energy as in (a)?

- a. (a)  $0.0225\text{ J}$ ; (b)  $25.7\text{ V}$
- b. (a)  $0.0225\text{ J}$ ; (b)  $36.4\text{ V}$
- c. (a)  $0.138\text{ J}$ ; (b)  $223\text{ V}$
- d. (a)  $0.138\text{ J}$ ; (b)  $157\text{ V}$

[4] Each capacitor in the combination shown in Figure 2 has a breakdown voltage of 19.0V.

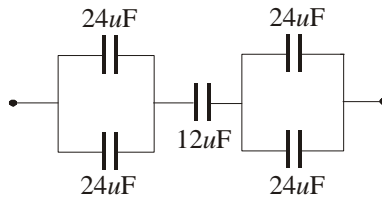

Figure 2

What is the breakdown voltage of the combination?

- a. 57.0 V
- b. 28.5 V
- c. 95.0 V
- d. 19.0 V

[5] When a potential difference of 190 V is applied to the plates of a parallel plate capacitor, the plates carry a surface charge density of  $20.0 \text{ nC/cm}^2$ . What is the spacing between the plates?

- a.  $8.41 \text{ } \mu\text{m}$
- b.  $0.119 \text{ } \mu\text{m}$
- c.  $0.429 \text{ } \mu\text{m}$
- d.  $2.33 \text{ } \mu\text{m}$

[6] A parallel plate capacitor is constructed using a dielectric material whose dielectric constant is 4.00 and whose dielectric strength is  $2.50 \times 10^8 \text{ V/m}$ . The desired capacitance is  $0.450 \mu\text{F}$ , and the capacitor must withstand a maximum potential difference of 4000V. Find the minimum area of the capacitor plates.

- a.  $3.25 \text{ m}^2$
- b.  $0.203 \text{ m}^2$
- c.  $0.795 \text{ m}^2$
- d.  $0.814 \text{ m}^2$

### Multiple choice question for part 2

---

[7] Find the equivalent capacitance between points a and b in the combination of capacitors shown in Figure 3.

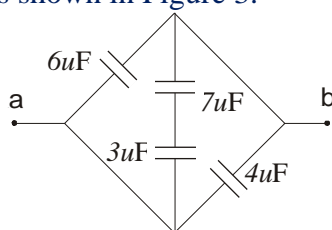

Figure 3

- a.  $1.12 \mu\text{F}$
- b.  $1.94 \mu\text{F}$
- c.  $1.12 \mu\text{F}$
- d.  $20.0 \mu\text{F}$

---

[8] The inner conductor of a coaxial cable has a radius of 0.500 mm, and the outer conductor's inside radius is 4.00 mm. The space between the conductors is filled with polyethylene, which has a dielectric constant of 2.30 and a dielectric strength of  $20.0 \times 10^6 \text{ V/m}$ . What is the maximum potential difference that this cable can withstand?

- a. 30.4 kV
- b. 70.0 kV
- c. 20.8 kV
- d. 166 kV

---

[9] Two capacitors when connected in parallel give an equivalent capacitance of 27.0 pF and give an equivalent capacitance of 4.00 pF when connected in series. What is the capacitance of each capacitor?

- a. 10.4 pF, 16.6 pF
- b. 9.76 pF, 44.2 pF
- c. 9.77 pF, 17.23 pF
- d. 4.88 pF, 22.12 pF

---

[10] An isolated capacitor of unknown capacitance has been charged to a potential difference of 100 V. When the charged capacitor is then connected in parallel to an unchanged  $10.0 \mu\text{F}$  capacitor, the voltage across the combination is 30.0 V. Calculate the unknown capacitance.

- a.  $7.00 \mu\text{F}$

- b.  $2.31 \mu\text{F}$
- c.  $4.29 \mu\text{F}$
- d.  $13.0 \mu\text{F}$

[11] Four capacitors are connected as shown in Figure 4.

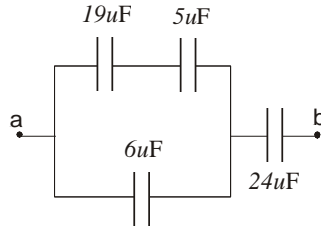

Figure 4

(a) Find the equivalent capacitance between points a and b. (b) Calculate the charge on each capacitor if  $\Delta V_{ab} = 11.0 \text{ V}$ .

- a. (a)  $28.8 \mu\text{F}$ ; (b)  $q_{19} = 1254, q_5 = 330, q_6 = 396, q_{24} = 317$
- b. (a)  $7.04 \mu\text{F}$ ; (b)  $q_{19} = 30.8, q_5 = 30.8, q_6 = 46.7, q_{24} = 77.4$
- c. (a)  $28.8 \mu\text{F}$ ; (b)  $q_{19} = 1584, q_5 = 1584, q_6 = 396, q_{24} = 317$
- d. (a)  $7.04 \mu\text{F}$ ; (b)  $q_{19} = 148, q_5 = 38.9, q_6 = 46.7, q_{24} = 77.4$

[12] A  $40.0\mu\text{F}$  spherical capacitor is composed of two metal spheres one having a radius four times as large as the other. If the region between the spheres is a vacuum, determine the volume of this region.

- a.  $5.18 \times 10^{18} \text{ m}^3$
- b.  $1.46 \times 10^{13} \text{ m}^3$
- c.  $1.37 \times 10^{13} \text{ m}^3$
- d.  $5.26 \times 10^{18} \text{ m}^3$

[13] A  $18.0 \text{ m}$  metal wire is cut into five equal pieces that are then connected side by side to form a new wire the length of which is equal to one-fifth the original length. What is the resistance of this new wire?

- a.  $90.0 \Omega$
- b.  $3.60 \Omega$
- c.  $0.720 \Omega$
- d.  $19.0 \Omega$

*Multiple choice question for part 2*

---

[14] A small sphere that carries a charge of 8.00 nC is whirled in a circle at the end of an insulating string. The angular frequency of rotation is  $100\pi$  rad/s. What average current does the rotating rod represent?

- a. 251 nA
- b. 400 nA
- c. 127 nA
- d. 160 nA

---

[15] An aluminum wire with a cross sectional area of  $4.00 \times 10^{-6} \text{ m}^2$  carries a current of 5.00A. Find the drift speeds of the electrons in the wire. The density of aluminum is  $2.70 \text{ g/cm}^3$ . (Assume that one electron is supplied by each atom.)

- a.  $9.45 \times 10^{-4} \text{ m/s}$
- b.  $1.30 \times 10^{-4} \text{ m/s}$
- c.  $1.78 \times 10^{-7} \text{ m/s}$
- d.  $7.71 \times 10^{-3} \text{ m/s}$

---

[16] A 16.0 V battery is connected to a  $100 \Omega$  resistor. Neglecting the internal resistance of the battery, calculate the power dissipated in the resistor.

- a. 0.0625 W
- b. 1.60 W
- c. 16.0 W
- d. 0.391 W

---

[17] An electric current is given by  $I(t) = 120.0 \sin(1.10\pi t)$ , where  $I$  is in amperes and  $t$  is in seconds. What is the total charge carried by the current from  $t = 0$  to  $t = 1/220 \text{ s}$ ?

- a. 0.347 C
- b. 120 C
- c. 415 C
- d. 1.09 C

---

[18] A resistor is constructed of a carbon rod that has a uniform cross sectional area of 3.00mm When a potential difference of 19.0 V is applied

across the ends of the rod, there is a current of  $2.00 \times 10^{-3}$  A in the rod. Find (a) the resistance of the rod and (b) the rod's length.

- a. (a) 1.05 k $\Omega$ ; (b) 998 mm
- b. (a) 9.50 k $\Omega$ ; (b) 111 mm
- c. (a) 9.50 k $\Omega$ ; (b) 814 mm
- d. (a) 1.05 k $\Omega$ ; (b) 902 mm

---

[19] A copper cable is designed to carry a current of 500 A with a power loss of 1.00 W/m. What is the required radius of this cable?

- a. 3.68 cm
- b. 6.76 cm
- c. 13.5 cm
- d. 7.36 cm

---

[20] In a certain stereo system, each speaker has a resistance of 6.00  $\Omega$ . The system is rated at 50.0 W in each channel, and each speaker circuit includes a fuse rated at 2.00 A. Is the system adequately protected against overload?

- a. yes
- b. no
- c. n/a
- d. n/a

---

[21] Compute the cost per day of operating a lamp that draws 1.70 A from a 110 V line if the cost of electrical energy is \$0.06kWh.

- a. 0.458 cents/day
  - b. 45.8 cents/day
  - c. 1.12 cents/day
  - d. 26.9 cents/day
- 

[22] Calculate the power dissipated in each resistor of the circuit of Figure 5.

## Multiple choice question for part 2

---

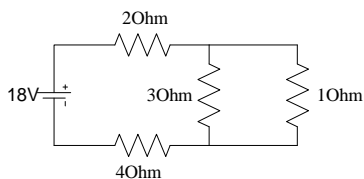

*Figure 5*

- a.  $P_2 = 14.2 \text{ W}$ ,  $P_4 = 28.4 \text{ W}$ ,  $P_3 = 1.33 \text{ W}$ ,  $P_1 = 4.00 \text{ W}$
  - b.  $P_2 = 162 \text{ W}$ ,  $P_4 = 81.0 \text{ W}$ ,  $P_3 = 60.8 \text{ W}$ ,  $P_1 = 20.3 \text{ W}$
  - c.  $P_2 = 14.2 \text{ W}$ ,  $P_4 = 28.4 \text{ W}$ ,  $P_3 = 12.0 \text{ W}$ ,  $P_1 = 0.444 \text{ W}$
  - d.  $P_2 = 162 \text{ W}$ ,  $P_4 = 81.0 \text{ W}$ ,  $P_3 = 20.3 \text{ W}$ ,  $P_1 = 60.8 \text{ W}$
- 
- 

[23] When two unknown resistors are connected in series with a battery, 225 W is dissipated with a total current of 7.00 A. For the same total current, 45.0 W is dissipated when the resistors are connected in parallel. Determine the values of the two resistors.

- a. 3.32  $\Omega$ , 2.40  $\Omega$
  - b. 3.32  $\Omega$ , 7.92  $\Omega$
  - c. 1.27  $\Omega$ , 5.86  $\Omega$
  - d. 1.27  $\Omega$ , 3.32  $\Omega$
- 
- 

[24] A fully charged capacitor stores 14.0 J of energy. How much energy remains when its charge has decreased to half its original value?

- a. 3.50 J
  - b. 7.00 J
  - c. 56.0 J
  - d. 14.0 J
- 
-



[25] For the current shown in Figure 6, calculate (a) the current in the  $1.00\ \Omega$  resistor and (b) the potential difference between the points a and b.

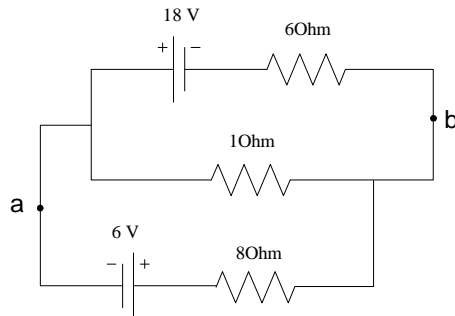

Figure 6

- a. (a) 2.90 A; (b) -2.90 V
- b. (a) 1.74 A; (b) -1.74 V
- c. (a) 1.74 A; (b) 1.74 V
- d. (a) 2.90 A; (b) 2.90 V

[26] Three  $4.00\ \Omega$  resistors are connected as in Figure 7.

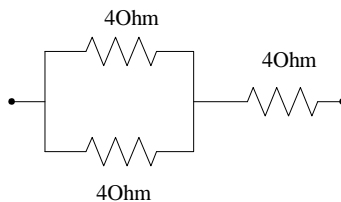

Figure 7

Each can dissipate a maximum power of 34.0 W without being excessively heated. Determine the maximum power the network can dissipate.

- a. 434 W
- b. 22.7 W
- c. 51.0 W
- d. 102 W

[27] Consider the circuit shown in Figure 8.

Multiple choice question for part 2

---

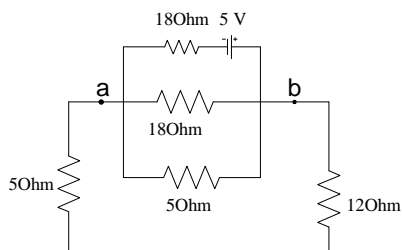

Figure 8

Find (a) the current in the  $12.0 \Omega$  resistor and (b) the potential difference between points a and b.

- a. (a) 0.0554 A; (b) 0.665 V
- b. (a) 0.294 A; (b) 5.00 V
- c. (a) 0.250 A; (b) 4.25 V
- d. (a) 0.0442 A; (b) 0.751 V

---

[28] Two resistors connected in series have an equivalent resistance of  $590 \Omega$ . When they are connected in parallel, their equivalent resistance is  $125 \Omega$ . Find the resistance of each resistor.

- a.  $327 \Omega$ ,  $263 \Omega$
  - b.  $327 \Omega$ ,  $202 \Omega$
  - c.  $180 \Omega$ ,  $410 \Omega$
  - d.  $180 \Omega$ ,  $54.8 \Omega$
- 

#####  
#####  
#####

## Solution of the multiple choice questions

Q. No.	Answer	Q. No.	Answer
1	d	15	b
2	d	16	c
3	c	17	a
4	b	18	c
5	a	19	a
6	b	20	a
7	c	21	d
8	c	22	a
9	d	23	d
10	c	24	a
11	b	25	b
12	a	26	c
13	c	27	d
14	b	28	c

dddddddddddddddd

**LECTURES IN GENERAL PHYSICS**

# *Electrostatic*

*Principles and Applications*

Dr. Hazem Falah Sakeek

Al-Azhar University - Gaza

*Part Two*

# APPENDICES

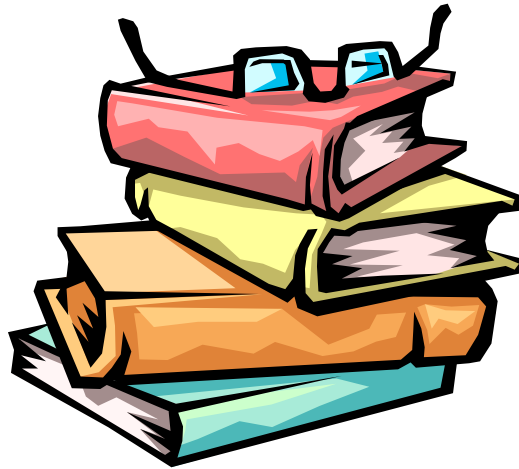

## **APPENDIX (A)**

### **Some practical application of electrostatic**



# Understanding the Van de Graaff generator

Now that you understand something about electrostatics and static electricity, it is easy to understand the purpose of the Van de Graaff generator. A Van de Graaff generator is a device designed to create static electricity and make it available for experimentation.

The American physicist Robert Jemison Van de Graaff invented the Van de Graaff Generator in 1931. The device that bears his name has ability to produce extremely high voltages - as high as 20 million volts. Van de Graaff invented the Van de Graaff Generator to supply the high energy needed for early particle accelerators. These accelerators were known as *atom smashers* because they accelerated sub-atomic particles to very high speeds and then "smashed" them into the target atoms. The resulting collisions create other subatomic particles and high-energy radiation such as X-rays. The ability to create these high-energy collisions is the foundation of particle and nuclear physics.

Van de Graaff Generators are described as "constant current" electrostatic devices. When you put a load on a Van de Graaff generator, the current (amperage) remains the same. It's the voltage that varies with the load. In the case of the Van de Graaff generator, as you approach the output terminal (sphere) with a grounded object, the voltage will decrease, but as stated above, the current will remain the same. Conversely, batteries are known as "constant voltage" devices because when you put a load on them, the voltage remains the same. A good example is your car battery. A fully charged car battery will produce about 12.75 volts. If you turn on your headlights and then check your battery voltage, you will see that it remains relatively unchanged (providing your battery is healthy). At the same time, the current will vary with the load. For example, your headlights may require 10 amps, but your windshield wipers may only require 4 amps. Regardless of which one you turn on, the voltage will remain the same.

There are two types of Van de Graaff generators, one that uses a high voltage power supply for charging and one that uses belts and rollers for charging. Here we will discuss the belts and rollers type.

Van de Graaff generators are made up of a motor, two rollers, a belt, two brush assemblies, and an output terminal (usually a metal or aluminum sphere), as shown in the figure:

When the motor is turned on, the lower roller (charger) begins turning the belt. Since the belt is made of rubber and the lower roller is covered in silicon tape, the lower roller begins to build a negative charge and the belt builds a positive charge. By now, you should understand why this charge imbalance occurs, but you may want to look at the Triboelectric Series again (see chapter 1). Silicon is more negative than rubber; therefore, the lower roller is capturing electrons from the belt as it passes over the roller. It is important to realize that the charge on the roller is much more concentrated than the charge on the belt. Because of this concentration of charge, the roller's electric field is much stronger than the belt's at the location of the roller and lower brush assembly. The strong negative charge from the roller now begins to do two things:

1. It repels the electrons near the tips of the lower brush assembly. Metals are good conductors because they are basically positive atoms surrounded by easily movable electrons. The brush assembly now has wire tips that are positively charged because the electrons have moved away from the tips, towards the connection at the motor housing.

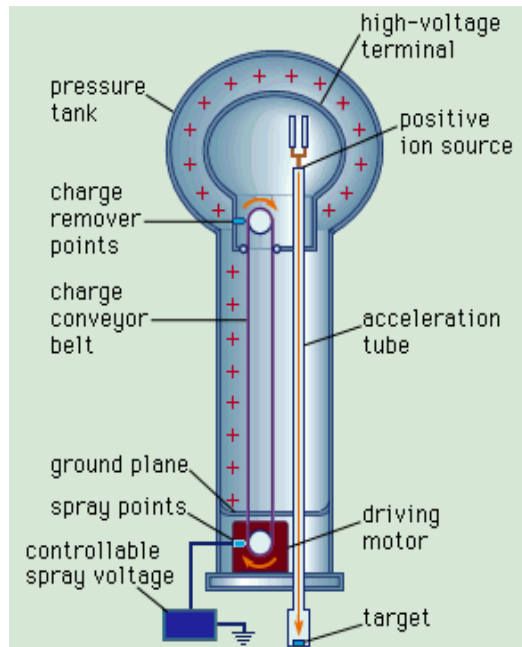

2. It begins to strip nearby air molecules of their electrons. When an atom is stripped of its electrons, it is said to be plasma, the fourth state of matter. So we have free electrons and positively charged atoms of air existing between the roller and the brush. The electrons repel from the roller and attract to the electron-less brush tips while the positive atoms attract to the negatively charged roller.



The positively charged atomic nuclei from the air molecules try to move toward the negatively charged roller, but the belt is in the way. So now the belt gets "coated" with the positive charge, which it then carries away from the roller.

You should now understand that as long as there is air between the lower roller and brush assembly, the Van de Graaff generator will continue to charge the belt. Theoretically, the Van de Graaff generator can continue to charge forever. Unfortunately, dirt and other impurities in the surroundings will limit the actual charge that develops on the sphere.

Let's return to the belt. The belt, as we left it, is positively charged and rolling toward the upper roller and upper brush assembly. Since I used nylon for my upper roller, it wants to repel the charge on the belt. The upper brush assembly is connected to the inside of the sphere and hangs near the upper roller and belt location. The electrons in the brush move to the tips of the wires, because they are attracted to the positively charged belt. Once the air breaks down as before, the positive atomic nuclei of air are attracted to the brush. At the same time, the free electrons in the air move to the belt. When a charged object touches the inside of a metal container, the container will take all of the charge, leaving the object neutral. The excess charge then shows up on the outside surface of the container. Here our container is the sphere. It is through this effect that the de Graaff generator is able to achieve its huge voltages (over one million volts). For the Van de Graaff generator, the belt is the charged object delivering a continuous positive charge to the sphere.

One last note is a neutral material is used for the upper roller; thus the belt becomes neutral after the sphere sucks its excess charge away.



## Cathode Ray Oscilloscope

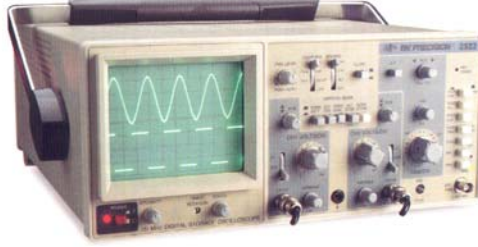

### جهاز راسم الذبذبات الكهربائية

**OSCILLOSCOPE**, electronic instrument that records changes in the voltage of an electric or electronic circuit by a trace of light on the face of a cathode-ray tube (CRT). Oscilloscopes are widely used throughout industry and in scientific laboratories to test and adjust electronic equipment and to follow extremely rapid oscillations in electric voltages; the oscilloscope is capable of following changes that occur within several billionths of a second. Special converters attached to an oscilloscope can convert mechanical vibrations, sound waves, and other forms of oscillatory motion into electrical impulses that can be observed on the face of the CRT.

Oscilloscopes measure 2 things: voltage and time (and with time, often, frequency). An electron beam is swept across a phosphorescent screen horizontally (X direction) at a known rate (say 1 sweep in a millisecond). An input signal is used to change the position of the beam in the Y direction. The trace left behind can be used to measure the voltage of the input signal (off the Y axis) and the duration or frequency can be read off the X axis.

تتبعث الإلكترونات من الفتيلة بواسطة التسخين. ثم تعجل هذه الإلكترونات في اتجاه الانود بواسطة فرق جهد بناء على العلاقة التالية

$$\frac{1}{2}mv^2 = qV$$

حيث أن  $q$  شحنة الإلكترون و  $V$  فرق الجهد بين الكاثود والانود.

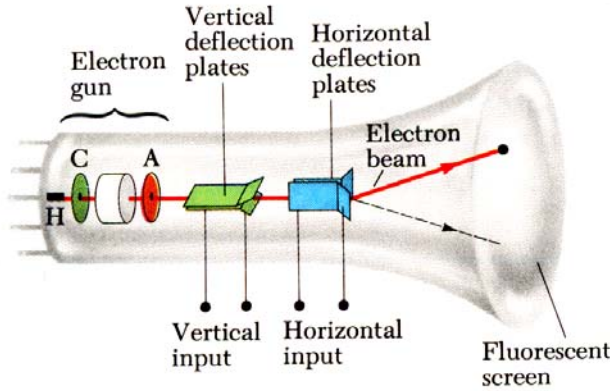

يمر شعاع الإلكترونات المعجلة بين زوجين من الألواح. الزوج الأول في وضع أفقي X-plate والزوج الثاني في وضع رأسي Y-plate. وبتطبيق فرق جهد بين اللوحين X-plate واللوحين Y-plate يمكن التحكم في مسار الشعاع الإلكتروني أفقياً ورأسياً. غالباً يكون X-plate موصلاً في مصدر داخلي يعطى فرق جهد متغير له شكل سن المنشار sawtooth waveform وهو يتحكم في الثابت الزمني (Time base)

أما الإشارة المراد تتبعها تطبق على اللوحين Y-plate من خلال القناة Channel وفي أغلب أجهزة CRT الحديثة يكون هنالك قناتين وبالتالي شعاعين إلكترونيين. في النهاية يصطدم الشعاع الإلكتروني بشاشة فوسفورية كما هو الحال في جهاز التلفزيون وترسم شكل الموجة الداخلة إلى تلك القناة على الشاشة.

Speed of response is the cathode-ray oscilloscope's chief advantage over other plotting devices. General-purpose oscilloscopes have plotting frequencies of up to 100 megahertz (MHz). Response times as rapid as 2,000 MHz are achievable with special-purpose, high-speed oscilloscopes.

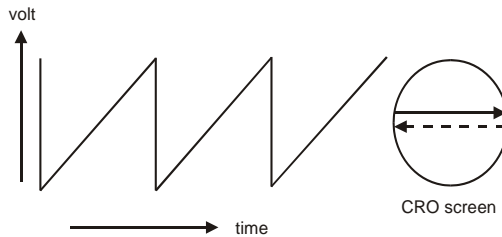

## XEROGRAPHY (Photocopier)

**XEROGRAPHY**, electrostatic dry-printing process for the reproduction of images or documents, widely employed in commerce and industry in copying machines

The process was invented by the American printer Chester F. Carlson (1906–68) in 1937 and first commercially developed in 1950. It makes use of the principle of photoconductivity, that is, that certain substances resist passage of an electric current except when struck by light. Silicon, germanium, and selenium are poor conductors of electricity, but when light energy is absorbed by some of their electrons, the electrons are able to pass from one atom to another, thus allowing a current to flow when a voltage is applied. When the light is removed, their conductivity again becomes low. **Xerography** employs a photoconductive insulating layer, such as selenium, on an aluminum or other conductive metal support.

The layer is charged electrostatically, either with positive or negative ions, the polarity of the charge depending on the type of photoconductive insulating layer selected. When the plate is exposed, in a camera or photographic machine, those areas of the coating subjected to light lose a varying portion of the charge, depending upon the intensity of the illumination. Thus, the variation of the amount of charge retained on the coated metal plate is established as an electrical or electrostatic pattern of the image. The image is rendered visible by sprinkling over the exposed plate a special, charged powder, which carries an opposite charge



to the initial charge applied to the plate and insulating layer. The powder adheres to those areas that have retained their charge. The print is obtained by covering the plate with paper, then applying a charge over the back of the paper of the same polarity as the initial charge applied to the photoconductive insulating layer. In this way the opposite charged powders are transferred to the paper surface. The powder image is then fused onto the paper by exposure to solvent vapors or heat to make the image permanent.

The entire xerographic process can be carried out, in high-speed mechanized equipment, in less than 5 seconds, and it is comparatively

inexpensive to make these images because the photoconductive insulating layer can be recycled many thousand times. The process has found its primary usefulness in copying office documents and in low-volume duplication of data.

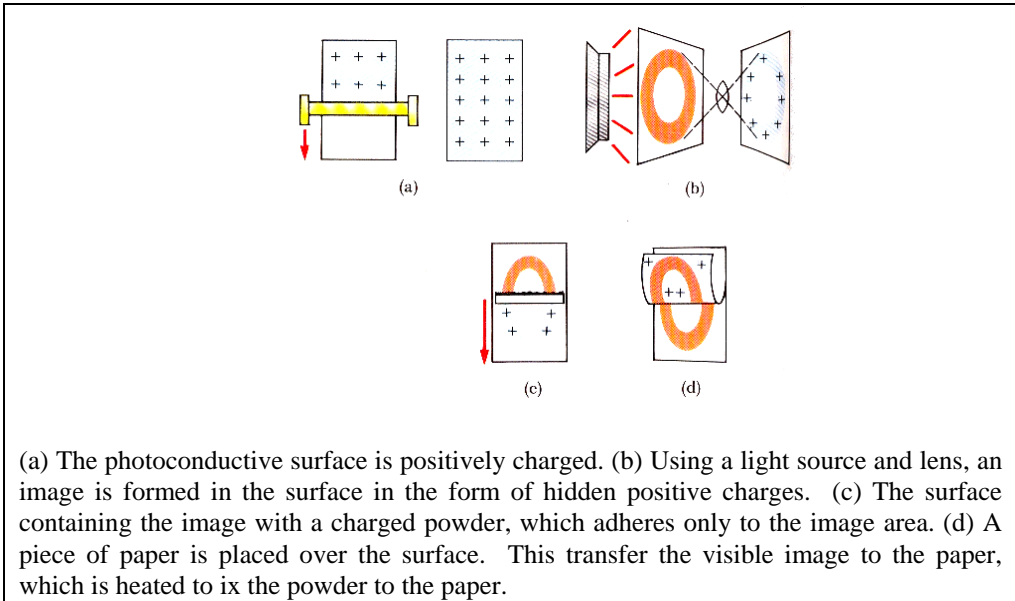

The xerographic method also permits the making, quickly and cheaply; of paper offset masterplates for low-to-medium-volume runs on office offset-printing presses. The method has also been applied to the production of X-ray images in a technique that is known as xeroradiography and is used in mammography for early detection of breast cancer. Xerography is applied in industrial nondestructive testing.

A variety of automatic xerographic machines are available today that make office copies on the push of a button and that are almost unable to fail. Xerographic machines can reproduce half-tone photographs and can enlarge or reduce copy. They can be set to print on either one or both sides of paper, to produce automatically a large or small number of copies without further intervention by the operator, and to sort and collate. A development of the late 1970s is color xerography. The economy, versatility, and flexibility of the xerographic process have created legal problems relating to copyright and helped stimulate numerous changes in the copyright laws in the U.S. and elsewhere.





# Battery

Battery, is a devices that convert chemical energy directly into electrical energy. Although the term battery, in strict usage, designates an assembly of two or more voltaic cells capable of such energy conversion, it is commonly applied to a single cell of this kind.

The mechanism by which a battery generates an electric current involves the arrangement of constituent chemicals in such a manner that electrons are released from one part of the battery and made to flow through an external circuit to another part. The part of the battery at which the electrons are released to the circuit is called the anode, or the negative electrode; the part that receives the electrons from the circuit is known as the cathode, or the positive electrode. (In a device that consumes current--*e.g.*, electroplating cell, electron tube, etc.--the term anode is often applied to the positive electrode, while the negative electrode is called the cathode.)

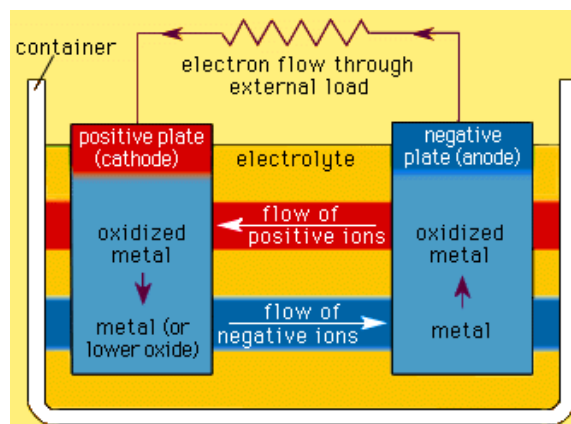

The first battery appears to have been constructed about 1800 by Alessandro Volta, a professor of natural philosophy at the University of Pavia in Italy. This device, later known as the voltaic pile, was composed of a series of silver and zinc disks in pairs, each of which was separated with a sheet of pasteboard saturated in salt water. A current was produced when the uppermost disk of silver was connected by a wire to the bottom disk of zinc. In 1836 the English chemist John Daniell developed what is considered the classic form of the voltaic cell.

A voltaic cell is composed of two chemicals with different electron-attracting capabilities that are immersed in an electrolyte and connected to each other through an external circuit. These two chemicals are called an electrochemical couple. In a zinc-acid cell, for example, the electrochemical

couple is a zinc-hydrogen ion couple. The reaction that occurs between an electrochemical couple in a voltaic cell is an oxidation-reduction reaction.

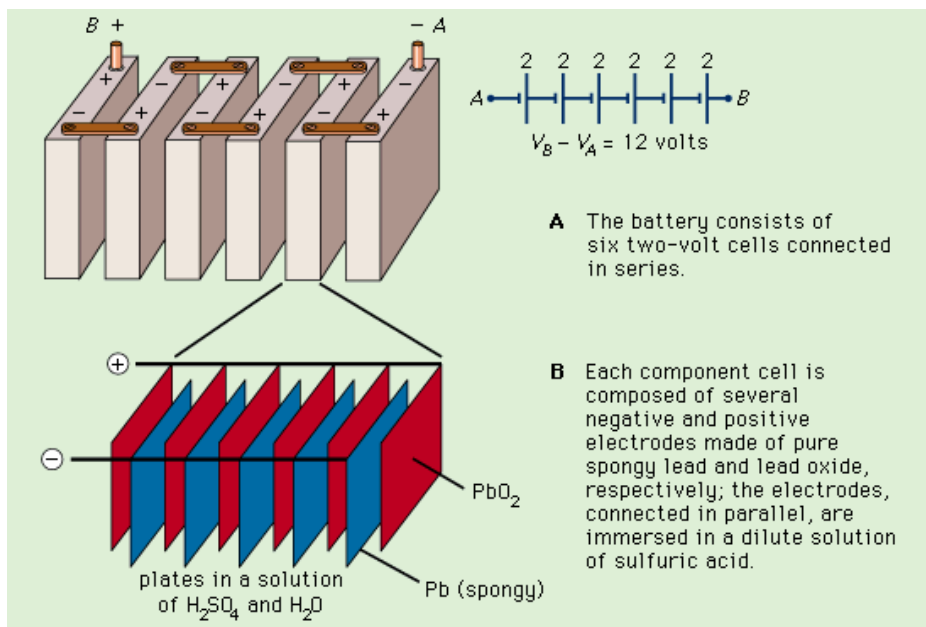

At rest, a voltaic cell exhibits a potential difference (voltage) between its two electrodes that is determined by the amount of chemical energy available when an electron is transferred from one electrode to the other and is thus subject to the chemical nature of the materials used in the electrode. The current that flows from a cell is determined by the resistance of the total circuit, including that of the cell itself. A low-resistance cell is required if extremely large currents are desired. This can be achieved by the utilization of electrodes with large areas. In short, the maximum current that can be drawn from a cell is dependent on the area of the electrodes. Whenever a current flows, the voltage of a cell decreases because of internal resistance of the cell and the slowness of the chemical process at the electrodes.

A voltaic cell has a limited energy content, or capacity, which is generally given in ampere-hours and determined by the quantity of electrons that can be released at the anode and accepted at the cathode. When all of the chemical energy of the cell has been consumed--usually because one of the electrodes has been completely exhausted--the voltage falls to zero and will not recover. The capacity of the cell is determined by the quantity of active ingredients in the electrode.



There are two major types of voltaic cells: primary batteries and secondary, or storage, batteries. (The latter are sometimes also called accumulators.) Primary cells are constructed in such a way that only one continuous or intermittent discharge can be obtained. Secondary devices, on the other hand, are constructed so that they can be discharged and then recharged to approximately their original state. The charging process is the reverse of the discharge process; therefore, the electrode reactions in these batteries must be reversible.

### ***Primary batteries.***

Several varieties of primary cells are available. These include dry, wet, and solid electrolyte.

Dry cells are not actually dry but contain an aqueous electrolyte that is unspillable or immobilized. Many of these cells are sealed to prevent seepage of the electrolyte or reaction products. Common examples of such primary batteries are acidic dry cells (*e.g.*, carbon-zinc cells), used in flashlights, toys, and certain transistorized portable radios; alkaline dry cells, employed in cameras, tape recorders, and electric razors; and mercury cells, utilized in hearing aids and photographic flash guns.

Wet cells contain a free and mobile electrolyte. They are used when service requirements include large capacity and moderately high currents, as, for example, in telephone and telegraph circuits and in signal systems for marine, mine, highway, and railway use. The Lalande cell of zinc-copper oxide--sodium hydroxide and the zinc-air-sodium hydroxide cell have been widely employed for such applications. Often included among wet primary cells is the so-called reserve battery, in which either magnesium-silver chloride or magnesium-cuprous chloride serves as the electrode material. Because these compounds are readily attacked by electrolytes (either seawater or liquid ammonia), the battery is assembled with the electrolyte stored in a separate container. The electrolyte is added immediately before use. The reserve battery has been utilized primarily for military applications.

Solid electrolyte cells contain electrolytes of crystalline salts such as silver iodide or lead chloride that have predominantly ionic conductivity. They are suitable for long-term operations that require very low drain or for stand-by services. Miniature versions of solid salt electrolyte batteries have been developed for use in various kinds of electronic devices.

***Secondary batteries.***

Such batteries consist of an assemblage of several identical voltaic cells. Of the various types of storage batteries available, the lead-acid type is the most widely used. It serves as the power source for the electrical systems of many kinds of motor vehicles, particularly automobiles and trucks. It is also commonly used to provide electricity for emergency lighting and communication circuits. The active constituents of a lead-acid battery are sulfuric acid and two sets of plates (electrodes)--one containing pure lead and the other lead dioxide. Each component cell consists of several of these plate pairs connected in parallel and is capable of delivering approximately two volts. Three or six cells are connected in series to make a 6- or 12-volt battery, respectively. The sulfuric-acid electrolyte in each of the cells is stored separately in its own compartment. During discharge, the plate materials are converted into lead sulfate and the sulfuric acid is depleted. Discharge stops before all component chemicals are exhausted, usually when the acid can no longer reach the active materials. Charging the battery by passing a direct current through it reverses the chemical changes, displacing the sulfate from the plates and causing a rise in the specific gravity of the sulfuric acid.

Another important type of storage battery is the nickel-cadmium battery, which operates much like the lead-acid variety but with different chemical ingredients. It consists of a nickel hydroxide cathode and a cadmium anode immersed in an electrolyte of potassium hydroxide solution. The nickel-cadmium battery is lighter in weight than are other storage batteries and can be hermetically sealed. Because of these features, nickel-cadmium cells are utilized in many kinds of cordless appliances and other portable equipment.

A third storage battery of significance is the silver-zinc type. The anode of this device is composed of a porous plate of zinc, the cathode of a silver screen pasted with silver oxide, and the electrolyte of a solution of potassium hydroxide saturated with zinc hydroxide. Silver-zinc batteries can be charged and discharged only a limited number of times because of the structure used to separate the electrodes. They do have, however, a high energy-to-weight ratio and are suitable for applications in which light weight is important.



## **APPENDIX (B)**

### **Answer of Some Selected Problems**



## APPENDIX (B)

### Answer of Some Selected Problems

#### Chapter 2

- 2.1)  $1.6 \times 10^9 \text{N}$  repelling each other  
 2.4)  $1.2 \times 10^{-5} \text{C}$  and  $3.8 \times 10^{-5} \text{C}$   
 2.5)  $q = 1/2Q$   
 2.6)  $8.5 \times 10^{-2} \text{N}$  in the positive x-axis  
 2.8)  $0.873 \text{N}$  at  $330^\circ$   
 2.11)  $(0, 0.853 \text{m})$   
 2.13) (b)  $\pm 2.4 \times 10^{-8} \text{C}$

#### Chapter 3

- 3.2) (a)  $(-5.58 \times 10^{-11} \text{N/C})\mathbf{j}$ ,  
 (b)  $(1.02 \times 10^{-7} \text{N/C})\mathbf{j}$   
 3.3) (a)  $(-5.20 \times 10^3 \text{N/C})\mathbf{j}$ , (b)  
 $(2.93 \times 10^3 \text{N/C})\mathbf{j}$  and (c)  $5.85 \times 10^3 \text{N/C}$  at  
 $225^\circ$ .  
 3.4)  $5.6 \times 10^{-11} \text{C}$   
 3.7)  $1 \times 10^3 \text{N/C}$  in the direction of the  
 beam  
 3.8) (a)  $1.5 \times 10^3 \text{N/C}$ , (b)  $2.4 \times 10^{-16} \text{N}$  up,  
 (c)  $1.6 \times 10^{-26} \text{N}$  and (d)  $1.5 \times 10^{10}$ .  
 3.15)  $E = \frac{q}{\pi \epsilon_0 a^2}$  along the bisector,  
 away from the triangle  
 3.17) (a)  $2.7 \times 10^6 \text{m/s}$ , (b)  $1 \times 10^3 \text{N/C}$

#### Chapter 4

- 4.2)  $5.56 \times 10^5 \text{N.m}^2/\text{C}$   
 4.7) (a) zero, (b)  $5.4 \times 10^3 \text{N/C}$  and (c)  
 $540 \text{N/C}$  both radially outward  
 4.9) (a) zero, (b)  $125 \times 10^4 \text{N/C}$  radially  
 outward, (c)  $639 \text{N/C}$  radially outward and  
 (d) no charge  
 4.10) (a) zero, (b)  $8 \times 10^7 \text{N/C}$  radially  
 outward (c) zero and (d)  $7.35 \times 10^6 \text{N/C}$   
 radially outward  
 4.11) (i)  $E = \frac{Qr}{4 \pi \epsilon_0 a^3}$ ,  
 (ii)  $E = \frac{Q}{4 \pi \epsilon_0 r^2}$ ,  
 (iii) zero (iv) zero and (v) inner Q; outer  
 zero.  
 4.12) (a) zero, (b)  $3.66 \times 10^5 \text{N/C}$ , (c)  
 $1.46 \times 10^6 \text{N/C}$  and (d)  $6.5 \times 10^5 \text{N/C}$  radially  
 outward  
 4.13) (a)  $0.713 \mu\text{C}$ , (b)  $5.7 \mu\text{C}$   
 4.14) (i)  $E = \frac{q}{2 \pi \epsilon_0 l r}$  radially outward,  
 (ii)-q on both inner and outer surfaces,  
 (iii)  $E = \frac{q}{2 \pi \epsilon_0 l r}$  radially outward  
 4.15) (a) zero, (b)  $7.2 \times 10^6 \text{N/C}$  away from  
 the center  
 4.16)  $5.08 \times 10^5 \text{N/C}$  up  
 4.17) (i) zero, (ii)  $E = \frac{\sigma}{\epsilon_0}$ , and (iii) zero

## Chapter 5

- 5.2)  $6.41 \times 10^{-19} \text{C}$   
 5.4) 0.89m  
 5.5) 2m  
 5.6) 119nC, 2.67m  
 5.11) (a)  $-4500 \text{V}$ , (b) same as (a) because potential is scalar quantity  
 5.13) (a)  $2.5 \times 10^6 \text{V}$ , (b) 5.1J, and (c) 6.9J  
 5.15) (a)  $-386 \text{eV}$  positive binding energy would have to be put in to separate them.  
 (b) 103V

## Chapter 6

- 6.1)  $18 \mu\text{C}$   
 6.3)  $4.3 \text{pF}$   
 6.5) (a)  $q_1=9 \mu\text{C}$ ;  $q_2=16 \mu\text{C}$ ;  $q_3=9 \mu\text{C}$ ;  $q_4=16 \mu\text{C}$ .  
 (b)  $q_1=8.4 \mu\text{C}$ ;  $q_2=17 \mu\text{C}$ ;  $q_3=11 \mu\text{C}$ ;  $q_4=14 \mu\text{C}$ .  
 6.6) (a)  $V_f=2 \text{V}$ ; (b)  $U_i = \frac{1}{2} \frac{\epsilon_o A V^2}{d}$ ,  
 $U_f=2U_i$ ; (c)  $W = \frac{1}{2} \frac{\epsilon_o A V^2}{d}$   
 6.7) (a)  $4.8 \times 10^{-4} \text{C}$ , (b)  $V_4=120 \text{V}$ ;  $V_6=80 \text{V}$   
 6.11) 3300  
 6.12) (b)  $3.2 \mu\text{F}$   
 6.14)  $800 \text{pJ}$ ,  $5.79 \text{mJ/m}^3$   
 6.16) (a)  $4 \mu\text{F}$ , (b) 8V;  $24 \mu\text{C}$ , 4V;  $24 \mu\text{C}$ , 12V,  $24 \mu\text{C}$   
 6.18)  $0.188 \text{m}^2$   
 6.19) (a)  $q_1=2.1 \times 10^{-4} \text{C}$ ;  $q_2=1.1 \times 10^{-4} \text{C}$ ;  $q_3=3.2 \times 10^{-4} \text{C}$ . (b)  $V_1=V_2=21 \text{V}$ ;  $V_3=79 \text{V}$ .  
 (c)  $U_1=2.2 \times 10^{-3} \text{J}$ ;  $U_2=1.1 \times 10^{-3} \text{J}$ ;  $U_3=1.3 \times 10^{-3} \text{J}$ ;

## Chapter 7

- 7.1) (a)  $1.2 \times 10^3 \text{C}$ , (b)  $7.5 \times 10^{21}$  electron  
 7.2)  $1.5 \times 10^{-15} \text{m/s}$   
 7.6)  $3.23 \times 10^6 / \Omega \cdot \text{m}$   
 7.9) (a) 2.4 iron being larger, (b) no  
 7.10) 6.43A  
 7.12)  $2 \times 10^6 \text{s}$   
 7.13) (a) 15V copper; 85V iron, (b)  $8.5 \times 10^7 \text{A/m}^2$ , (c) 1.5V/m copper; 8.5V/m iron  
 7.18) (a) 11A, (b) 11 $\Omega$  and (c) 1100kcal

## Chapter 8

- 8.1) 7.67 $\Omega$   
 8.3) (a) 1.79A, (b) 10.4V  
 8.5) 12 $\Omega$   
 8.7) 2.4 $\Omega$   
 8.9) 8 $\Omega$   
 8.10) (a) 27.3V, (b) 2.73A; 1.37A; 0.91A  
 8.11) (b) 1.99A; 1.17A; 0.819  
 8.12) (6/11)R  
 8.13) 14W; 28.5W; 1.33W; 4w  
 8.17)  $i_1=50 \text{mA}$  to the right;  $i_2=60 \text{mA}$  down;  $V_{ab}=9 \text{V}$   
 8.18) (a) the left branch, 0.67A down; center branch, 0.33A up; the right branch, 0.33A up  
 8.19) (a) -10.4V

**APPENDIX (C)**  
**The international system of  
units (SI)**

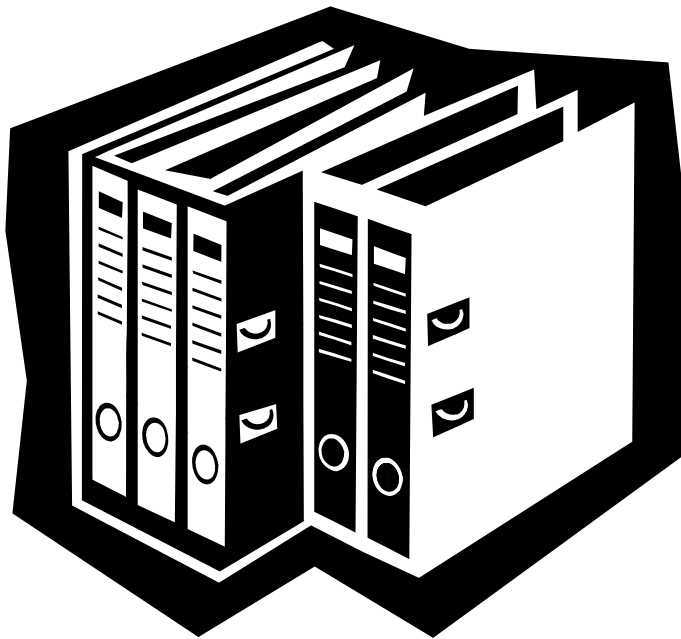

## APPENDIX (C)

# The international system of units (SI)

SI Units <http://tcaep.co.uk/science/siunits/index.htm>

### SI Units and Definitions

#### The Fundamental SI Units

Quantity	Unit	Abbreviation
Mass	kilogram	kg
Length	meter	m
Time	second	s
Temperature	kelvin	K
Electrical current	ampere	A
Luminous intensity	candela	cd
Amount of substance	mole	mol
Plane angle	radian	rad
Solid angle	steradian	sr

#### SI Prefixes

Prefix	Symbol	Factor	Prefix	Symbol	Factor
yatta	Y	$10^{24}$	deci	d	$10^{-1}$
zetta	Z	$10^{21}$	centi	c	$10^{-2}$
exa	E	$10^{18}$	milli	m	$10^{-9}$
peta	P	$10^{15}$	micro	$\mu$	$10^{-6}$
tera	T	$10^{12}$	nano	n	$10^{-9}$
giga	G	$10^9$	pico	p	$10^{-12}$
mega	M	$10^6$	femto	f	$10^{-15}$
kilo	k	$10^3$	atto	a	$10^{-18}$
hecto	h	$10^2$	zepto	z	$10^{-21}$
deca	da	$10^1$	yocto	y	$10^{-24}$

SI Derived Units expressed in terms of base units

Quantity	Name	Symbol
area	square meter	m <sup>2</sup>
volume	cubic meter	m <sup>3</sup>
speed, velocity	meter per second	m/s
acceleration	meter per second square	m/s <sup>2</sup>
wave number	1 per meter	m <sup>-1</sup>
density, mass density	kilogram per cubic meter	kg/m <sup>3</sup>
specific volume	cubic meter per kilogram	m <sup>3</sup> /kg
current density	ampere per square meter	A/m <sup>2</sup>
magnetic field strength	ampere per meter	A/m
concentration	mole per cubic meter	mol/m <sup>3</sup>
luminance	candela per square meter	cd/m <sup>2</sup>

SI Derived Units with special names

Quantity	Name	Symbol	Expression in terms of other units	Expression in terms of SI base units
frequency	hertz	Hz		s <sup>-1</sup>
force	newton	N		m kg s <sup>-2</sup>
pressure, stress	pascal	Pa	N/m <sup>2</sup>	m <sup>-1</sup> kg s <sup>-2</sup>
energy, work, quantity of heat	joule	J	N m	m <sup>2</sup> kg s <sup>-2</sup>
power, radiation flux	watt	W	J/s	m <sup>2</sup> kg s <sup>-3</sup>
electric charge	coulomb	C		s A
electric potential difference	volt	V	W/A	m <sup>2</sup> kg s <sup>-3</sup> A <sup>-1</sup>
electromotive force	volt	V	W/A	m <sup>2</sup> kg s <sup>-3</sup> A <sup>-1</sup>
capacitance	farad	F	C/V	m <sup>-2</sup> kg <sup>-1</sup> s <sup>4</sup> A <sup>2</sup>
electric resistance	ohm	Ω	V/A	m <sup>2</sup> kg s <sup>-3</sup> A <sup>-2</sup>
electric conductance	siemens	S	A/V	m <sup>-2</sup> kg <sup>-1</sup> s <sup>3</sup> A <sup>2</sup>
magnetic flux	weber	Wb	V s	m <sup>2</sup> kg s <sup>-2</sup> A <sup>-1</sup>
magnetic flux density	tesla	T	Wb/m <sup>2</sup>	kg s <sup>-2</sup> A <sup>-1</sup>
inductance	henry	H	Wb/A	m <sup>2</sup> kg s <sup>-2</sup> A <sup>-2</sup>
temperature	degree celsius	°C		K
luminance flux	lumen	lm		cd sr
luminance	lux	lx	lm/m <sup>2</sup>	m <sup>-2</sup> cd sr
activity of radionuclide	becquerel	Bq		s <sup>-1</sup>
absorbed dose	gray	Gy	J/kg	m <sup>2</sup> s <sup>-2</sup>
dose equivalent	sievert	Sv	J/kg	m <sup>2</sup> s <sup>-2</sup>



## SI Derived Units Expressed by Means of Special Names

Quantity	Name	Symbol	Expression in terms of SI base units
Dynamic Viscosity	pascal second	Pa s	$\text{m}^{-1} \text{kg s}^{-1}$
Moment of Force	newton meter	N m	$\text{M}^2 \text{kg s}^{-2}$
Surface Tension	newton per metre	N/m	$\text{kg s}^{-2}$
Heat Flux Density / Irradiance	watt per square metre	W/m <sup>2</sup>	$\text{kg s}^{-3}$
Heat Capacity / Entropy	joule per kelvin	J/K	$\text{M}^2 \text{kg s}^{-2} \text{K}^{-1}$
Specific Heat Capacity / Specific Entropy	joule per kilogram kelvin	J/(kg K)	$\text{m}^2 \text{s}^{-2} \text{K}^{-1}$
Specific Energy	joule per kilogram	J/kg	$\text{M}^2 \text{s}^{-2}$
Thermal Conductivity	watt per metre kelvin	W/(m K)	$\text{m kg s}^{-3} \text{K}^{-1}$
Energy Density	joule per cubic metre	J/m <sup>3</sup>	$\text{m}^{-1} \text{kg s}^{-2}$
Electric Field Strength	volt per metre	V/m	$\text{m kg s}^{-3} \text{A}^{-1}$
Electric Charge Density	coulomb per cubic metre	C/m <sup>3</sup>	$\text{m}^{-3} \text{s A}$
Electric Flux Density	coulomb per square metre	C/m <sup>2</sup>	$\text{m}^{-2} \text{s A}$
Permittivity	farad per metre	F/m	$\text{m}^{-3} \text{kg}^{-1} \text{s}^4 \text{A}^2$
Permeability	henry per metre	H/m	$\text{m kg s}^{-2} \text{A}^{-2}$
Molar Energy	joule per mole	J/mol	$\text{m}^2 \text{kg s}^{-2} \text{mol}^{-1}$
Molar Entropy / Molar Heat Capacity	joule per mole kelvin	J/(mol K)	$\text{m}^2 \text{kg s}^{-2} \text{K}^{-1} \text{mol}^{-1}$
Exposure (x and $\gamma$ rays)	coulomb per kilogram	C/kg	$\text{kg}^{-1} \text{s A}$
Absorbed Dose Rate	gray per second	Gy/s	$\text{M}^2 \text{s}^{-3}$

### SI Supplementary Units

Quantity	Name	Symbol	Expression in terms of SI base units
Plane Angle	radian	rad	$\text{m m}^{-1} = 1$
Solid Angle	steradian	sr	$\text{m}^2 \text{m}^{-2} = 1$

### SI Derived Units Formed Using Supplementary Units

Quantity	Name	Symbol
Angular Velocity	radian per second	rad/s
Angular Acceleration	radian per second squared	rad/s <sup>2</sup>
Radiant Intensity	watt per steradian	W/sr
Radiance	watt per square metre steradian	W/(m <sup>2</sup> sr)

## Metric and Imperial Measures

### Length

1 centimeter	cm	= 10 mm	= 0.3937 in
1 meter	m	= 100 cm	= 1.0936 yd
1 kilometer	km	= 1000 m	= 0.6214 mile
1 inch	in		= 2.54 cm
1 yard	yd	= 36 in	= 0.9144 m
1 mile		= 1760 yd	= 1.6093 km

### Surface or Area

1 sq cm	cm <sup>2</sup>	= 100 mm <sup>2</sup>	= 0.1550 in <sup>2</sup>
1 sq m	m <sup>2</sup>	= 10000 cm <sup>2</sup>	= 1.1960 yd <sup>2</sup>
1 sq km	km <sup>2</sup>	= 100 ha	= 0.3861 mile <sup>2</sup>
1 sq in	in <sup>2</sup>		= 6.4516 cm <sup>2</sup>
1 sq yd	yd <sup>2</sup>	= 9 ft <sup>2</sup>	= 0.8361 m <sup>2</sup>
1 sq mile	mile <sup>2</sup>	= 640 acres	= 2.59 km <sup>2</sup>

### Volume and Capacity

1 cu cm	cm <sup>3</sup>		= 0.0610 in <sup>3</sup>
1 cu m	m <sup>3</sup>	= 1000 dm <sup>3</sup>	= 1.3080 yd <sup>3</sup>
1 liter	l	= 1 dm <sup>3</sup>	= 0.220 gal
1 hectoliter	hl	= 100 l	= 21.997 gal
1 cu in	in <sup>3</sup>		= 16.387 cm <sup>3</sup>
1 cu yd	yd <sup>3</sup>	= 27 ft <sup>3</sup>	= 0.7646 m <sup>3</sup>
1 pint	pt	= 20 fl oz	= 0.56831 l
1 gallon	gal	= 8 pt	= 4.546 l

### Mass

1 gram	g	= 1000 mg	= 0.0353 oz
1 kilogram	kg	= 1000 g	= 2.2046 lb
1 tonne	t	= 1000 kg	= 0.9842 ton
1 ounce	oz	= 437.5 grains	= 28.35 g
1 pound	lb	= 16 oz	= 0.4536 kg
1 ton		= 20 cwt	= 1.016 t

### US Measures

1 US dry pint	= 33.60 in <sup>3</sup>	= 0.5506 l
1 US liquid pint	= 0.8327 imp pt	= 0.4732 l
1 US gallon	= 0.8327 imp gal	= 3.785 l
1 short cwt	100 lb	= 45.359 kg
1 short ton	2000 lb	= 907.19 kg

## Symbols Greek Alphabet

<http://tcaep.co.uk/science/symbols/greek.htm>

A	α	alpha
B	β	beta
Γ	γ	gamma
Δ	δ	delta
E	ε	epsilon
Z	ζ	zeta
H	η	eta
Θ	θ	theta
I	ι	iota
K	κ	kappa
Λ	λ	lambda
M	μ	mu
N	ν	nu

Ξ	ξ	xi
Ο	ο	omicron
Π	π	pi
Ρ	ρ	rho
Σ	σ	sigma
Τ	τ	tau
Υ	υ	upsilon
Φ	φ	phi
Χ	χ	chi
Ψ	ψ	psi
Ω	ω	omega
Ξ	ξ	xi

# Periodic Table

	1	2	3	4	5	6	7	8	9	10	11	12	13	14	15	16	17	18	
	I	II		III	IV	V	VI	VII	VIII			I	II	III	IV	V	VI	VII	VIII
1	1 <u>H</u>																	2 <u>He</u>	
2	3 <u>Li</u>	4 <u>Be</u>											5 <u>B</u>	6 <u>C</u>	7 <u>N</u>	8 <u>O</u>	9 <u>F</u>	10 <u>Ne</u>	
3	11 <u>Na</u>	12 <u>Mg</u>											13 <u>Al</u>	14 <u>Si</u>	15 <u>P</u>	16 <u>S</u>	17 <u>Cl</u>	18 <u>Ar</u>	
4	19 <u>K</u>	20 <u>Ca</u>		21 <u>Sc</u>	22 <u>Ti</u>	23 <u>V</u>	24 <u>Cr</u>	25 <u>Mn</u>	26 <u>Fe</u>	27 <u>Co</u>	28 <u>Ni</u>	29 <u>Cu</u>	30 <u>Zn</u>	31 <u>Ga</u>	32 <u>Ge</u>	33 <u>As</u>	34 <u>Se</u>	35 <u>Br</u>	36 <u>Kr</u>
5	37 <u>Rb</u>	38 <u>Sr</u>		39 <u>Y</u>	40 <u>Zr</u>	41 <u>Nb</u>	42 <u>Mo</u>	43 <u>Tc</u>	44 <u>Ru</u>	45 <u>Rh</u>	46 <u>Pd</u>	47 <u>Ag</u>	48 <u>Cd</u>	49 <u>In</u>	50 <u>Sn</u>	51 <u>Sb</u>	52 <u>Te</u>	53 <u>I</u>	54 <u>Xe</u>
6	55 <u>Cs</u>	56 <u>Ba</u>	<u>La</u> †	71 <u>Lu</u>	72 <u>Hf</u>	73 <u>Ta</u>	74 <u>W</u>	75 <u>Re</u>	76 <u>Os</u>	77 <u>Ir</u>	78 <u>Pt</u>	79 <u>Au</u>	80 <u>Hg</u>	81 <u>Tl</u>	82 <u>Pb</u>	83 <u>Bi</u>	84 <u>Po</u>	85 <u>At</u>	86 <u>Rn</u>
7	87 <u>Fr</u>	88 <u>Ra</u>	<u>Ac</u> ‡	103 <u>Lr</u>	104 <u>Rf</u>	105 <u>Db</u>	106 <u>Sg</u>	107 <u>Bh</u>	108 <u>Hs</u>	109 <u>Mt</u>	110 <u>Uun</u>	111 <u>Uuu</u>	112 <u>Uub</u>	113	114 <u>Uuq</u>	115	116 <u>Uuh</u>	117	118 <u>Uuo</u>
† Lanthanides				57 <u>La</u>	58 <u>Ce</u>	59 <u>Pr</u>	60 <u>Nd</u>	61 <u>Pm</u>	62 <u>Sm</u>	63 <u>Eu</u>	64 <u>Gd</u>	65 <u>Tb</u>	66 <u>Dy</u>	67 <u>Ho</u>	68 <u>Er</u>	69 <u>Tm</u>	70 <u>Yb</u>		
‡ Actinides				89 <u>Ac</u>	90 <u>Th</u>	91 <u>Pa</u>	92 <u>U</u>	93 <u>Np</u>	94 <u>Pu</u>	95 <u>Am</u>	96 <u>Cm</u>	97 <u>Bk</u>	98 <u>Cf</u>	99 <u>Es</u>	100 <u>Fm</u>	101 <u>Md</u>	102 <u>No</u>		

Obtained from <http://tcaep.co.uk/science/periodic/index.htm>

## APPENDIX (D)

### Physics Resources on the Web

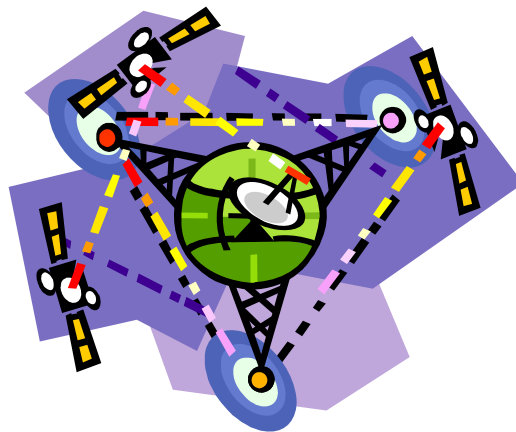

## APPENDIX (D)

### Physics Resources on the Web

#### Astronomy and Astrophysics

Center for Particle Astrophysics	<a href="http://physics7.berkeley.edu/home.html">http://physics7.berkeley.edu/home.html</a>
NASA Home Page	<a href="http://www.gsfc.nasa.gov/NASAhomepage.html">http://www.gsfc.nasa.gov/NASAhomepage.html</a>
Institutes of Astronomy	<a href="http://www.yahoo.com/Science/Astronomy/Institutes">http://www.yahoo.com/Science/Astronomy/Institutes</a>
WebStars: Astrophysics on the Web	<a href="http://www.gsfc.nasa.gov/WebStars/About.html">http://www.gsfc.nasa.gov/WebStars/About.html</a>
Astrotext:(Online hyper-textbook)	<a href="http://uu.gna.mit.edu:8001/uu-gna/text/astro">http://uu.gna.mit.edu:8001/uu-gna/text/astro</a>
Earth Views	<a href="http://images.jsc.nasa.gov/html/earth.htm">http://images.jsc.nasa.gov/html/earth.htm</a>
National Optical Observatories	<a href="http://www.noao.edu/noao.html">http://www.noao.edu/noao.html</a>
Observatories Around the World	<a href="http://www.yahoo.com/Science/Astronomy/Observatories">http://www.yahoo.com/Science/Astronomy/Observatories</a>
Space Telescope Science Institute	<a href="http://marvel.stsci.edu/top.html">http://marvel.stsci.edu/top.html</a>
Strasbourg Astronomical Data Center	<a href="http://cdsweb.u-strasbg.fr/CDS.html">http://cdsweb.u-strasbg.fr/CDS.html</a>
WebStars: Astrophysics in Cyberspace	<a href="http://guinan.gsfc.nasa.gov">http://guinan.gsfc.nasa.gov</a>
NASA Research Labs	<a href="http://www.yahoo.com/Government/Research_Labs/NASA">http://www.yahoo.com/Government/Research_Labs/NASA</a>
Astronomy Resources	<a href="http://www.stsci.edu/net-resources.html">http://www.stsci.edu/net-resources.html</a>

#### Computers in Physics and Laboratory Automation

The Computer Society	<a href="http://www.computer.org/">http://www.computer.org/</a>
Physical Computing A hands-on Tutorial.	<a href="http://www.itp.tsoa.nyu.edu/~alumni/dano/physical/physical.html">http://www.itp.tsoa.nyu.edu/~alumni/dano/physical/physical.html</a>
ADAC Manufacturers of Labtech Notebook.	<a href="http://www.adac.com/adac/index.html">http://www.adac.com/adac/index.html</a>
Keithley.	<a href="http://www.keithley.com/">http://www.keithley.com/</a>
Strawberry Tree.	<a href="http://www.strawberrytreetree.com/">http://www.strawberrytreetree.com/</a>
National Instruments.	<a href="http://www.natinst.com/">http://www.natinst.com/</a>
Links to TEX/LATEX Resources	<a href="http://www.it.kth.se/misc/external/teX-links.html">http://www.it.kth.se/misc/external/teX-links.html</a>
Computers in Physics(Journal)	<a href="http://www.aip.org/cip/ciphome.html">http://www.aip.org/cip/ciphome.html</a>
IEEE	<a href="http://www.ieee.org/spectrum/spechome.html">http://www.ieee.org/spectrum/spechome.html</a>

Spectrum(Journal)	
-------------------	--

## Condensed Matter Resources

Condensed Physics Labs	<a href="http://www-cmt.physics.brown.edu/cmt/resources/groups.html">http://www-cmt.physics.brown.edu/cmt/resources/groups.html</a>
Society of Vacuum Coaters	<a href="http://www.svc.org">http://www.svc.org</a>
Materials Research Society	<a href="http://www.mrs.org">http://www.mrs.org</a>

## Energy Research Resources

Department of Energy (DOE)	<a href="http://www.ofr.er.doe.gov/">http://www.ofr.er.doe.gov/</a>
DOE Office of Energy Research	<a href="http://www.er.doe.gov/">http://www.er.doe.gov/</a>
National Renewable Energy Laboratory (NREL)	<a href="http://www.nrel.gov/">http://www.nrel.gov/</a>
Solar Energy	<a href="http://www.netins.net/showcase/solarcatalog/">www.netins.net/showcase/solarcatalog /</a>

## High Energy Physics (HEP)

Fermilab	<a href="http://fnnews.fnal.gov/">http://fnnews.fnal.gov/</a>
HEP Labs Around the World	<a href="http://www.cern.ch/Physics/HEP.html">http://www.cern.ch/Physics/HEP.html</a>
HEP Information Center	<a href="http://www.hep.net/">http://www.hep.net/</a>
Experiments On-Line: home pages of individual HEP experiments	<a href="http://www-slac.slac.stanford.edu/find/explist.html">http://www-slac.slac.stanford.edu/find/explist.html</a>
Institute of High Energy Physics (China)	<a href="http://www.ihep.ac/ihep.html/">http://www.ihep.ac/ihep.html/</a>
PDG - The Particle Data Group	<a href="http://pdg.lbl.gov/">http://pdg.lbl.gov/</a>
FreeHEP - Library of High Energy Physics Software	<a href="http://heplibw3.slac.stanford.edu/find/fhmain.html">http://heplibw3.slac.stanford.edu/find/fhmain.html</a>
HEPIC - High-Energy Physics Information Center	<a href="http://www.hep.net/">http://www.hep.net/</a>

## Nuclear Physics

The American Nuclear Society	<a href="http://www.ans.org/">http://www.ans.org/</a>
DOE/NSF Nuclear Science Advisory Committee Home Page	<a href="http://www.nsf.gov/mps/phy/nuclear.htm">http://www.nsf.gov/mps/phy/nuclear.htm</a>
Radioactive Waste	<a href="http://www.nea.fr/html/trw/index.html/">http://www.nea.fr/html/trw/index.html/</a>
Fusion	<a href="http://www.yahoo.com/Science/Physics/Fusion/">http://www.yahoo.com/Science/Physics/Fusion/</a>
Austin Fusion Studies	<a href="http://w3fusion.ph.utexas.edu/">http://w3fusion.ph.utexas.edu/</a>
KVI Research Network	<a href="http://gopher://kviexp.kvi.nl/">gopher://kviexp.kvi.nl/</a>



## Optics

OpticsNet (Optical Society of America)	<a href="http://www.osa.org/homepage.html">http://www.osa.org/homepage.html</a>
--	---

## Particle Physics

Particle Physics and Cosmology	<a href="http://www.eagle.co.uk/ppi/home.html">http://www.eagle.co.uk/ppi/home.html</a>
Stanford Linear Accelerator Center	<a href="http://www.heplibw3.slac.stanford.edu/FIND/slac.html">http://www.heplibw3.slac.stanford.edu/FIND/slac.html</a>

## Relativity

Einstein in 3D	<a href="http://www.ncsa.uiuc.edu/Apps/GenRel/SC93/HOME_sc93.html">http://www.ncsa.uiuc.edu/Apps/GenRel/SC93/HOME_sc93.html</a>
Relativity	<a href="http://www.yahoo.com/Science/Physics/Relativity">http://www.yahoo.com/Science/Physics/Relativity</a>

## X-ray Resources

Advanced Photon Source Mosaic Home Page	<a href="http://www.aps.anl.gov/welcome.html">http://www.aps.anl.gov/welcome.html</a>
Cornell High Energy Synchrotron Source	<a href="http://www.tn.cornell.edu/">http://www.tn.cornell.edu/</a>
Harvard X-Ray Group - studies various interfaces: liquid helium films, liquid metals, langmuir monolayers etc.	<a href="http://hutrough.harvard.edu/">http://hutrough.harvard.edu/</a>
IIT Synchrotron Radiation Program	<a href="http://www.csrii.iit.edu/">http://www.csrii.iit.edu/</a>
International XAFS Society(2)	<a href="http://www.birzeit.edu/Science/Physics/X-Ray/International_XAFS_Society/">http://www.birzeit.edu/Science/Physics/X-Ray/International_XAFS_Society/</a>
Real Time Studies of Crystal Growth with X-rays	<a href="http://www.tn.cornell.edu/SIG/RTgrowth/RTgrowth.contents.html">http://www.tn.cornell.edu/SIG/RTgrowth/RTgrowth.contents.html</a>
SUNY Stony Brook X-ray Physics	<a href="http://xray1.physics.sunysb.edu/">http://xray1.physics.sunysb.edu/</a>
Synchrotron Radiation Materials Research Lab	<a href="http://syli34.physik.uni-bonn.de">http://syli34.physik.uni-bonn.de</a>
UWXAFS - XAFS analysis programs from the University of Washington	<a href="http://krazy.phys.washington.edu/">http://krazy.phys.washington.edu/</a>
X-Ray - development of industrial application of radiation after the discovery of x-rays.	<a href="http://www.ricoh.co.jp/net-messena/NDTWW/JSNDI/XRAY.html">http://www.ricoh.co.jp/net-messena/NDTWW/JSNDI/XRAY.html</a>
X-ray absorption data	<a href="http://www.csrii.iit.edu/periodic-table.html">http://www.csrii.iit.edu/periodic-table.html</a>
X-Ray WWW Server	<a href="http://xray.uu.se/">http://xray.uu.se/</a>
XAFS Database	<a href="http://xafsdb.iit.edu/database/">http://xafsdb.iit.edu/database/</a>

## Other Physics Topics on the Web

Electromagnetic Fields and Microwave Electronics	<a href="http://www.ifh.ee.ethz.ch/">http://www.ifh.ee.ethz.ch/</a>
Plasma Physics	<a href="http://plasma-gate.weizmann.ac.il/PlasmaI.html">http://plasma-gate.weizmann.ac.il/PlasmaI.html</a>
Sounds From Chaos	<a href="http://www.ccsr.uiuc.edu/People/gmk/Papers/Chua/SndRef.html">http://www.ccsr.uiuc.edu/People/gmk/Papers/Chua/SndRef.html</a>

## Periodic Tables of the Elements

The Periodic Table of Elements	<a href="http://www.cs.ubc.ca/elements/periodic-table">http://www.cs.ubc.ca/elements/periodic-table</a>
Periodic Table in Hypertext Format	<a href="http://www.cchem.berkeley.edu/Table/">http://www.cchem.berkeley.edu/Table/</a>
Periodic Table of the Elements (Online)	<a href="http://kuhttp.cc.ukans.edu/cwis/reference/Periodic/periodic.html">http://kuhttp.cc.ukans.edu/cwis/reference/Periodic/periodic.html</a>
Webelements Dept. of Chemistry, Univ. of Sheffield	<a href="http://www2.shef.ac.uk/chemistry/">http://www2.shef.ac.uk/chemistry/</a>

## Physics Laboratories Worldwide

Fermilab	<a href="http://fnnews.fnal.gov/">http://fnnews.fnal.gov/</a>
High energy physics labs around the world	<a href="http://www.cern.ch/Physics/HEP.html">http://www.cern.ch/Physics/HEP.html</a>
Condensed matter labs around the world	<a href="http://www-cmt.physics.brown.edu/cmt/resources/groups">http://www-cmt.physics.brown.edu/cmt/resources/groups</a>
Brookhaven National Laboratory	<a href="http://www.bnl.gov/">http://www.bnl.gov/</a>
Stanford Linear Accelerator Center	<a href="http://www.heplibw3.slac.stanford.edu/FIND/slac.html">http://www.heplibw3.slac.stanford.edu/FIND/slac.html</a>
Cornell High Energy Synchrotron Source	<a href="http://www.tn.cornell.edu/">http://www.tn.cornell.edu/</a>
NIST Physics Laboratory	<a href="http://physics.nist.gov">http://physics.nist.gov</a>

## Physics Related Journals

American Journal of Physics	<a href="http://www.amherst.edu/~aip/menu.html">http://www.amherst.edu/~aip/menu.html</a>
Computers in Physics	<a href="http://www.aip.org/cip/ciphome.html">http://www.aip.org/cip/ciphome.html</a>
IEEE Spectrum	<a href="http://www.ieee.org/spectrum/spechome.html">http://www.ieee.org/spectrum/spechome.html</a>

## Physics and Related Societies Worldwide

American Physical Society (APS)	<a href="http://aps.org/">http://aps.org/</a>
American Institute of Physics	<a href="http://www.aip.org">http://www.aip.org</a>
American Mathematical Society	<a href="http://e-math.ams.org">http://e-math.ams.org</a>
National Science Foundation	<a href="http://stis.nsf.gov">http://stis.nsf.gov</a>
The Electrochemical Society	<a href="http://www.electrochem.org">http://www.electrochem.org</a>
Society of Vacuum Coaters	<a href="http://www.electrochem.org">http://www.electrochem.org</a>
American Nuclear Society	<a href="http://www.ans.org">http://www.ans.org</a>
Optical Society of America	<a href="http://www.osa.org/homepage.html">http://www.osa.org/homepage.html</a>
The Computer Society	<a href="http://www.computer.org">http://www.computer.org</a>
The European Physical Society	<a href="http://www.nikhef.nl/www/pub/eps/eps.html">http://www.nikhef.nl/www/pub/eps/eps.html</a>
Materials Research Society	<a href="http://www.mrs.org">http://www.mrs.org</a>

## Publishers and Published Resources

Addison Wesley - Physics	<a href="http://www.AW.com/he/Physics/PhysIndex.html">http://www.AW.com/he/Physics/PhysIndex.html</a>
John Wiley :Wiley College(Physics)	<a href="http://www.wiley.co.uk/college/math/phys/index.html">http://www.wiley.co.uk/college/math/phys/index.html</a>
AIP Press Catalog	<a href="http://www.aip.org/aippress">http://www.aip.org/aippress</a>
Institute of Physics Publishing	<a href="http://iop.org">http://iop.org</a>
Index of Abstracts	<a href="http://xxx.lanl.gov">http://xxx.lanl.gov</a>

## Other Physics Resource Sites

TIPTOP: The Internet Pilot TO Physics	<a href="http://www.tp.umu.se/TIPTOP">http://www.tp.umu.se/TIPTOP</a>
World Wide Web Virtual Library - Physics	<a href="http://www.w3.org/vl/Physics/Overview.html">http://www.w3.org/vl/Physics/Overview.html</a>
Einet Galaxy - Physics (Science)	<a href="http://www.einet.net/galaxy/Science/Physics.html">http://www.einet.net/galaxy/Science/Physics.html</a>
AIP's LinkLIST	<a href="http://www.aip.org/aip/physres.html">http://www.aip.org/aip/physres.html</a>
Yahoo: A Guide to the WWW - Physics	<a href="http://www.yahoo.com/Science/Physics">http://www.yahoo.com/Science/Physics</a>
World Wide Web Index - Physics	<a href="http://www.het.brown.edu/Physics/index.html">http://www.het.brown.edu/Physics/index.html</a>
Physics Servers and Services Around the World	<a href="http://www.physics.mcgill.ca/deptdocs/physics&lt;br/&gt;services.html">http://www.physics.mcgill.ca/deptdocs/physics services.html</a>
The Virtual Review	<a href="http://www.het.brown.edu/physics/review/index.html">http://www.het.brown.edu/physics/review/index.html</a>
Astronomical Internet Resources	<a href="http://marvel.stsci.edu/net-resources.html">http://marvel.stsci.edu/net-resources.html</a>

## APPENDIX (E)

### Bibliography



# APPENDIX (E)

## Bibliography

The Subject of this book “*Electrostatic: Principles and Applications*” may, of course, found in many textbooks of general physics. Some of the books, in particular, have good and interesting discussions of electrostatic (for example, R. A. Serway, Physics for scientists and engineering with modern physics. In the following list comprises books that relate either to individual topics or to the whole scope of the present text. In general these references are comparable in level to the present books.

Borowitz and Beiser “*Essentials of physics*”. Addison-Wesley Publishing Co., 1971.

Halliday, D. and Resnick, R. “*Physics (part two)*”. John Wiley & Sons, Inc., 1978.

Kubala, T.S., “*Electricity 2: Devices, Circuits and Materials*”, 2001

Nelkon, M. and Parker, P. “*Advanced level physics*”. Heinemann Educational Books Ltd., 1982.

Ryan, C.W., “*Basic Electricity : A Self-Teaching Guide*”, 1986

Sears, F.W., Zemansky, M.W. and Young, H.D. “*University physics*” Addison-Wesley Publishing Co., 1982.

Serway, R. A. “*Physics for scientists and engineering with modern physics*”. Saunders College Publishing, 1990.

Weidner, R.T. and Sells, R.L. “*Elementary physics: classical and modern*”. Allyn and Bacon, Inc., 1973.

Valkenburgh, N.V., “*Basic Electricity: Complete Course*”, 1993

## APPENDIX (F)

### Index



# APPENDIX (F)

## Index

### A

Ammeter, 213  
Ampere, 157

### B

Battery, 182, 238

### C

Capacitance, 125, capacitor,  
effect of dielectric, 145  
    parallel, 129  
    series, 130  
    Capacitor, 125  
Energy stored in capacitor, 135  
Charge density, 63  
Charge distribution, 63  
Charging a capacitor, 205  
Circuit, 183  
    multiloop, 195  
    single-loop, 190  
Conduction electrons, 9  
Conductivity, 159  
Conductor, 9  
Conservation of charge, 11  
Coulomb's law, 16  
Current density, 157  
and drift speed, 157  
Current loop, 190, 195

### D

Dielectric constant, 145  
Direction of current, 157  
Discharging a capacitor, 207

### E

Electron, 12  
Electric dipole, 36  
Electric dipole moment, 37  
Electric force, 16  
Electric field, 32  
Electric flux, 54  
Electromotive force, 182  
Electron volt, 89  
Energy density 136  
Equipotential surface, 85  
Equivalent capacitance, 129  
Equivalent resistance, 165

### F

Flux 54  
Field lines of force 38

### G

Gauss's law, 59  
    infinite line of charge, 64  
    infinite plane of charge, 65  
    spherically symmetric  
charge, 67  
Gaussian surface, 57

## I

Internal resistance, 183

## J

Junction, in circuit, 187

Loop theorem, 195

## K

Kirchhoff's first rule, 187

Kirchhoff's second rule, 188

## N

Net flux, 55

## O

Ohm's law, 159

Oscilloscope, cathode-ray, 234

## P

Permittivity constant, 16

Plasma, 8

Potentiometer, 215

Power, 163

## Q

Quantization, 12

## R

Resistivity, 159

Resistance, 159

parallel connection, 166

Series connection, 165

## S

Semiconductor, 9

Series connection of, capacitors,

130, resistors, 165

SI units of, capacitance, 110

charge, 16

conductivity, 159

current, 157

electric field, 32, 86

electric flux, 54

electric potential, 84

RC circuit, 205

Stored energy, in capacitor, 135

Stable equilibrium, 84

## T

Triboelectric series, 6

## U

Unstable equilibrium, 48

## V

Van de Graff generator, 5, 231

Volt, 84

Voltmeter, 213

## W

Wheatstone bridge, 214

## X

Xerography, 236