

## **I. INTRODUCTION:**

Fiber optics is a major building block in the telecommunication infrastructure. Its high bandwidth capabilities and low attenuation characteristics make it ideal for gigabit transmission and beyond. In this semester, you will be introduced to the building blocks that make up a fiber optic communication system. You will learn about the different types of fiber and their applications, light sources and detectors, couplers, splitters, wavelength-division multiplexers, and state-of-the-art devices used in the latest high-bandwidth communication systems. Attention will also be given to system performance criteria such as power and rise-time budgets.

## **OBJECTIVES:**

Upon completion of this module, you will be able to:

- Identify the basic components of a fiber optic communication system.
- Discuss light propagation in an optical fiber.
- Identify the various types of optical fibers.
- Discuss the dispersion characteristics for various types of optical fibers.
- Identify selected types of fiber optic connectors.
- Calculate numerical aperture (N.A.), intermodal dispersion, and material dispersion.
- Calculate decibel and dBm power.
- Calculate the power budget for a fiber optic system.
- Calculate the bandwidth of an optical fiber.
- Describe the operation and applications of fiber optic couplers.
- Discuss the differences between LEDs and laser diodes with respect to performance Characteristics.

- Discuss the performance characteristics of optical detectors.
- Discuss the principles of wavelength-division multiplexing (WDM).
- Discuss the significance of the International Telecom Union grid (ITU grid).
- Discuss the use of erbium-doped fiber amplifiers (EDFA) for signal regeneration.
- Describe the operation and applications of fiber Bragg gratings.
- Describe the operation and application of fiber optic circulators.
- Describe the operation and application of fiber optic sensors.

## **BASIC CONCEPTS:**

### **Historical Introduction:**

Communication implies transfer of information from one point to another. When it is necessary to transmit information, such as speech, images, or data, over a distance, one generally uses the concept of *carrier wave communication*. In such a system, the information to be sent *modulates* an electromagnetic wave such as a radio wave, microwave, or light wave, which acts as a carrier. (*Modulation* means to vary the amplitude or frequency in accordance with an external signal.) This modulated wave is then transmitted to the receiver through a channel and the receiver demodulates it to retrieve the imprinted signal. The carrier frequencies associated with TV broadcast (~ 50–900 MHz) are much higher than those associated with AM radio broadcast (~ 600 kHz–20 MHz). This is due to the fact that, in any communication system employing electromagnetic waves as the carrier, the amount of information that can be sent increases as the frequency of the carrier is increased.<sup>1</sup> Obviously, TV broadcast has to carry much more information than AM broadcasts. Since optical beams have frequencies in the range of  $10^{14}$  to  $10^{15}$  Hz, the use of such beams as the carrier would imply a tremendously large

increase in the information-transmission capacity of the system as compared to systems employing radio waves or microwaves.

In a conventional telephone system, voice signals are converted into equivalent electrical signals by the microphone and are transmitted as electrical currents through metallic (copper or aluminum) wires to the local telephone exchange. Thereafter, these signals continue to travel as electric currents through metallic wire cable (or for long-distance transmission as radio/microwaves to another telephone exchange) usually with several repeaters in between. From the local area telephone exchange, at the receiving end, these signals travel via metallic wire pairs to the receiver telephone, where they are converted back into corresponding sound waves. Through such cabled wire-pair telecommunication systems, one can at most send 48 simultaneous telephone conversations intelligibly. On the other hand, in an optical communication system that uses glass fibers as the transmission medium and light waves as carrier waves, it is distinctly possible today to have 130,000 or more simultaneous telephone conversations (equivalent to a transmission speed of about 10 Gbit/s) through one glass fiber no thicker than a human hair. This large information-carrying capacity of a light beam is what generated interest among communication engineers and caused them to explore the possibility of developing a communication system using light waves as carrier waves.

## **II. Benefits of Fiber Optics:**

Fiber optic communication systems have many advantages over copper wire-based communication systems. These advantages include:

**• Long-distance signal transmission**

The low attenuation and superior signal quality of fiber optic communication systems allow communications signals to be transmitted over much longer distances than metallic-based systems without signal regeneration. In 1970, Kapron, Keck, and Maurer (at Corning Glass in USA) were successful in producing silica fibers with a loss of about 17 dB/km at a wavelength of 633 nm. Since then, the technology has advanced with tremendous rapidity. By 1985 glass fibers were routinely produced with extremely low losses ( $< 0.2$  dB/km). Voice-grade copper systems require in-line signal regeneration every one to two kilometers. In contrast, it is not unusual for communications signals in fiber optic systems to travel over 100 kilometers (km), or about 62 miles, without signal amplification or regeneration.

**• Large bandwidth, light weight, and small diameter**

Today's applications require an ever-increasing amount of bandwidth. Consequently, it is important to consider the space constraints of many end users. It is commonplace to install new cabling within existing duct systems or conduit. The relatively small diameter and light weight of optical cable make such installations easy and practical, saving valuable conduit space in these environments.

**• Nonconductive**

Another advantage of optical fibers is their dielectric nature. Since optical fiber has no metallic components, it can be installed in areas with electromagnetic interference (EMI), including radio frequency interference (RFI). Areas with high EMI include utility lines, power-carrying lines, and railroad tracks. All-dielectric cables are also ideal for areas of high lightning-strike incidence.

- **Security**

Unlike metallic-based systems, the dielectric nature of optical fiber makes it impossible to remotely detect the signal being transmitted within the cable. The only way to do so is by accessing the optical fiber. Accessing the fiber requires intervention that is easily detectable by security surveillance. These circumstances make fiber extremely attractive to governmental bodies, banks, and others with major security concerns.

### III. TOTAL INTERNAL REFLECTION (TIR):

At the heart of an optical communication system is the optical fiber that acts as the transmission channel carrying the light beam loaded with information. As mentioned earlier, the guidance of the light beam (through the optical fiber) takes place because of the phenomenon of total internal reflection (TIR), which we will now discuss. You learned about critical angles, TIR, etc. in the last year, *Basic Geometrical Optics*. You need now to refresh your memory and apply these ideas more directly to the physics of optical fibers. We first define the refractive index ( $n$ ) of a medium:

$$\boxed{n = \frac{c}{v}} \quad \dots (1)$$

where  $c$  ( $\approx 3 \times 10^8$  m/s) is the speed of light in free space and  $v$  represents the velocity of light in that medium. For example, for light waves,  $n \approx 1.5$  for glass and

$n \approx 1.33$  for water.

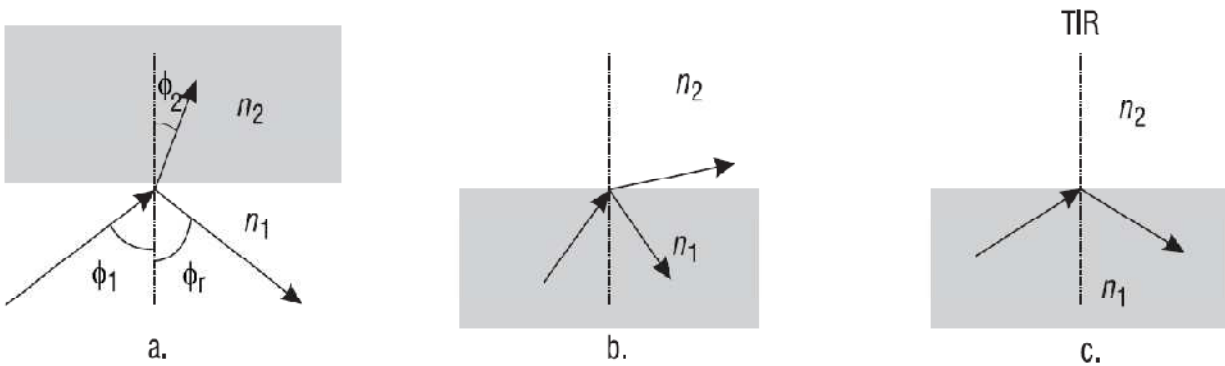

**Figure 1:** (a) A ray of light incident on a denser medium ( $n_2 > n_1$ ). (b) A ray incident on a rarer medium ( $n_2 < n_1$ ). (c) For  $n_2 < n_1$ , if the angle of incidence is greater than critical angle, it will undergo total internal reflection.

As you know, when a ray of light is incident at the interface of two media (like air and glass), the ray undergoes partial reflection and partial refraction as shown in Figure 1a. The vertical dotted line represents the normal to the surface. The angles  $\phi_1$ ,  $\phi_2$ , and  $\phi_r$  represent the angles that the incident ray, refracted ray, and reflected ray make with the normal. According to Snell's law and the law of reflection,

$$\boxed{n_1 \sin \phi_1 = n_2 \sin \phi_2 \quad \text{and} \quad \phi_1 = \phi_2} \quad \dots (2)$$

Further, the incident ray, reflected ray, and refracted ray lie in the same plane. In Figure 7-4a, since  $n_2 > n_1$  we must have (from Snell's law)  $\phi_2 < \phi_1$ , i.e., the ray will bend toward the normal.

On the other hand, if a ray is incident at the interface of a rarer medium ( $n_2 < n_1$ ), the ray will bend away from the normal (see Figure 1b). The angle of incidence, for which the angle of refraction is  $90^\circ$ , is known as the critical angle and is denoted by  $\phi_c$ . Thus, when  $\phi_2 = 90^\circ$ . When the angle of incidence exceeds the critical angle (i.e., when  $\phi_1 > \phi_c$ ), there is no refracted ray and we have total internal reflection (see Figure 1c).

$$\phi_1 = \phi_c = \sin^{-1}\left(\frac{n_2}{n_1}\right) \quad \dots (3)$$

The phenomenon of total internal reflection can be very easily demonstrated through a simple experiment as shown in Figure 2. A thick, semicircular glass disc is immersed in a glass vessel filled with water. A laser beam from a He-Ne laser or a laser pointer is directed toward the center of the semicircular disc so that it is incident normally on the glass surface and goes un-deviated toward  $O$  as shown in the figure. The angle of incidence (at the water-glass interface) is increased by rotating the glass disc about the point  $O$ , always keeping the incident ray normal to the circular disc. Eventually, when the angle of incidence exceeds the critical angle ( $\approx 62.5^\circ$ ), the laser beam undergoes TIR—as shown in Figure 2. The ray trace can be clearly seen when viewed from the top. If one puts a drop of ink in the water, the light path becomes very beautiful to look at! The experiment is very simple and we urge the reader to carry it out using a laser pointer.

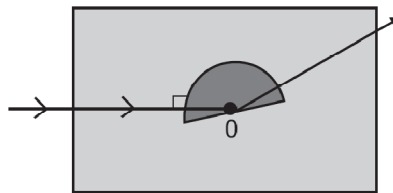

**Figure 2:** A simple laboratory experiment to demonstrate the phenomenon of TIR

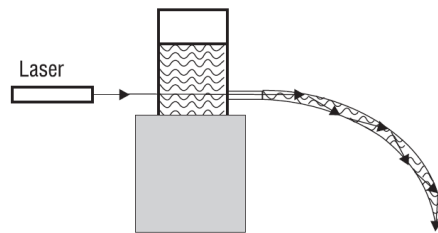

**Figure 3:** The concept of Tyndall's original experiment demonstrating the phenomenon of light guidance by TIR

We should mention that the phenomenon of guidance by multiple total internal reflections was first demonstrated by John Tyndall in 1854. In this demonstration, Tyndall showed that light travels along the curved path of water emanating from an illuminated vessel (see Figure 3). Actually, light undergoes TIR at the water-air interface, along the water path, as shown in Figure 3.

#### IV. THE OPTICAL FIBER:

Figure 4a shows an optical fiber, which consists of a (cylindrical) central dielectric core clad by a material of slightly lower refractive index. The corresponding refractive index distribution (in the transverse direction) is given by:

$$\boxed{\begin{array}{ll} n = n_1 & \text{for } r < a \\ n = n_2 & \text{for } r > a \end{array}} \quad \dots (4)$$

where  $n_1$  and  $n_2$  ( $< n_1$ ) represent respectively the refractive indices of core and cladding and  $a$  represents the radius of the core. We define a parameter  $\Delta$  through the following equations.

$$\boxed{\Delta \equiv \frac{n_1^2 - n_2^2}{2n_2^2}} \quad \dots (5)$$

When  $\Delta \ll 1$  (as is indeed true for silica fibers where  $n_1$  is very nearly equal to  $n_2$ ) we may write

$$\boxed{\Delta = \frac{(n_1 + n_2)(n_1 - n_2)}{2n_1^2} \approx \frac{(n_1 - n_2)}{n_1} \approx \frac{(n_1 - n_2)}{n_2}} \quad \dots (6)$$



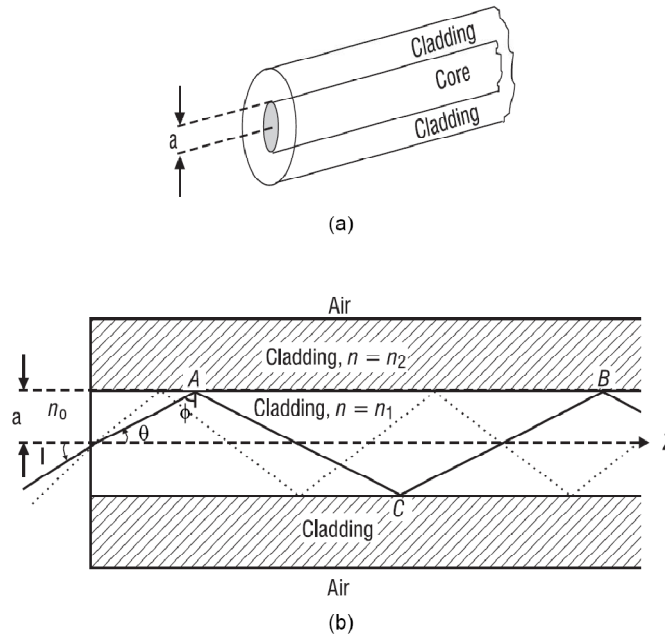

**Figure 4:** (a) A glass fiber consists of a cylindrical central core clad by a material of slightly lower refractive index. (b) Light rays impinging on the core-cladding interface at an angle greater than the critical angle are trapped inside the core of the fiber.

For a typical (multimode) fiber,  $a \approx 25 \mu\text{m}$ ,  $n_2 \approx 1.45$  (pure silica), and  $\Delta \approx 0.01$ , giving a core index of  $n_1 \approx 1.465$ . The cladding is usually pure silica while the core is usually silica doped with germanium. Doping by germanium results in a typical increase of refractive index from  $n_2$  to  $n_1$ .

Now, for a ray entering the fiber core at its end, if the angle of incidence  $\phi$  at the internal core-cladding interface is greater than the critical angle  $\phi_c [= \sin^{-1}(n_2/n_1)]$ , the ray will undergo TIR at that interface. Further, because of the cylindrical symmetry in the fiber structure, this ray will suffer TIR at the lower interface also and therefore be guided through the core by repeated total internal reflections. Even for a bent fiber, light guidance can occur through multiple total internal reflections (see Figures 3).

The necessity of a clad fiber (Figure 4)—rather than a bare fiber with no cladding—is clear. For transmission of light from one place to another, the fiber

must be supported. Supporting structures, however, may considerably distort the fiber, thereby affecting the guidance of the light wave. This is avoided by choosing a sufficiently thick cladding. Further, in a fiber bundle, in the absence of the cladding, light can leak through from one fiber to another. The idea of adding a second layer of glass (namely, the cladding) came (in 1955) from Hopkins and Kapany in the United Kingdom. However, during that time the use of optical fibers was mainly in image transmission rather than in communication. Indeed, the early pioneering works in fiber optics (in the 1950s) were by Hopkins and Kapany in the United Kingdom and by Van Heel in Holland. Their work led to the use of the fibers in optical devices and medical instruments.

## V. THE NUMERICAL APERTURE (NA):

We return to Figure 7-7b and consider a ray that is incident on the entrance face of the fiber core, making an angle  $i$  with the fiber axis. Let the refracted ray make an angle  $\theta$  with the same axis. Assuming the outside medium to have a refractive index  $n_0$  (which for most practical cases is unity), we get

$$\boxed{\begin{matrix} \sin i & = & n_1 \\ \sin \theta & = & n_0 \end{matrix}} \quad \dots (7)$$

Obviously, if this refracted ray is to suffer total internal reflection at the core-cladding interface, the angle of incidence  $\phi$  must satisfy the equation,

$$\boxed{\sin \phi (= \cos \theta) > \frac{n_2}{n_1}} \quad \dots (8)$$

Since  $\sin \theta = \sqrt{1 - \cos^2 \theta}$ , we will have

$$\sin \theta < \left[ 1 - \left( \frac{n_2}{n_1} \right)^2 \right]^{1/2} \quad \dots (9)$$

Let  $i_m$  represent the maximum half-angle of the acceptance cone for rays at the input end. Applying Snell's law at the input end and using Equations 7-5, 7-7, and 7-9, we must have  $I < i_m$ , where

$$\sin i_m = \left( n_1^2 - n_2^2 \right)^{1/2} = n_1 \sqrt{2\Delta} \quad \dots (10)$$

and we have assumed  $n_0 = 1$ ; i.e., the outside medium is assumed to be air. Thus, if a cone of light is incident on one end of the fiber, it will be guided through it provided the half-angle of the cone is less than  $i_m$ . This half-angle is a measure of the light-gathering power of the fiber. We define the numerical aperture ( $NA$ )—see Module 1-3, *Basic Geometrical Optics*—of the fiber by the following equation:

$$NA = \sin i_m = \sqrt{n_1^2 - n_2^2} = n_1 \sqrt{2\Delta} \quad \dots (11)$$

## VI. ATTENUATION IN OPTICAL FIBERS:

Attenuation and pulse dispersion represent the two most important characteristics of an optical fiber that determine the information-carrying capacity of a fiber optic communication system. Obviously, the lower the attenuation (and similarly, the lower the dispersion) the greater can be the required repeater spacing and therefore the lower will be the cost of the communication system. Pulse dispersion will be discussed in the next section, while in this section we will discuss briefly the various attenuation mechanisms in an optical fiber.

The attenuation of an optical beam is usually measured in decibels (dB). If an input power  $P_1$  results in an output power  $P_2$ , the power loss  $\alpha$  in decibels is given by

$$\alpha \text{ (dB)} = 10 \log_{10} (P_1/P_2) \quad \dots \text{ (12)}$$

Thus, if the output power is only half the input power, the loss is  $10 \log 2 \approx 3$  dB. Similarly, if the power reduction is by a factor of 100 or 10, the power loss is 20 dB or 10 dB respectively. If 96% of the light is transmitted through the fiber, the loss is about 0.18 dB. On the other hand, in a typical fiber amplifier, a power amplification of about 1000 represents a power gain of 30 dB.

Figure 5 shows the spectral dependence of fiber attenuation (i.e., loss coefficient per unit-length) as a function of wavelength of a typical silica optical fiber. The losses are caused by various mechanisms such as Rayleigh scattering, absorption due to metallic impurities and water in the fiber, and intrinsic absorption by the silica molecule itself. The Rayleigh scattering loss varies as  $1/\lambda_0^4$ , i.e., shorter wavelengths scatter more than longer wavelengths. Here  $\lambda_0$  represents the free space wavelength. This is why the loss coefficient decreases up to about 1550 nm. The two absorption peaks around 1240 nm and 1380 nm are primarily due to traces of OH<sup>-</sup> ions and traces of metallic ions. For example, even 1 part per million (ppm) of iron can cause a loss of about 0.68 dB/km at 1100 nm. Similarly, a concentration of 1 ppm of OH<sup>-</sup> ion can cause a loss of 4 dB/km at 1380 nm. This shows the level of purity that is required to achieve low-loss optical fibers. If these impurities are removed, the two absorption peaks will disappear. For  $\lambda_0 > 1600$  nm the increase in the loss coefficient is due to the absorption of infrared light by silica molecules. This is an intrinsic property of silica, and no amount of purification can remove this infrared absorption tail.

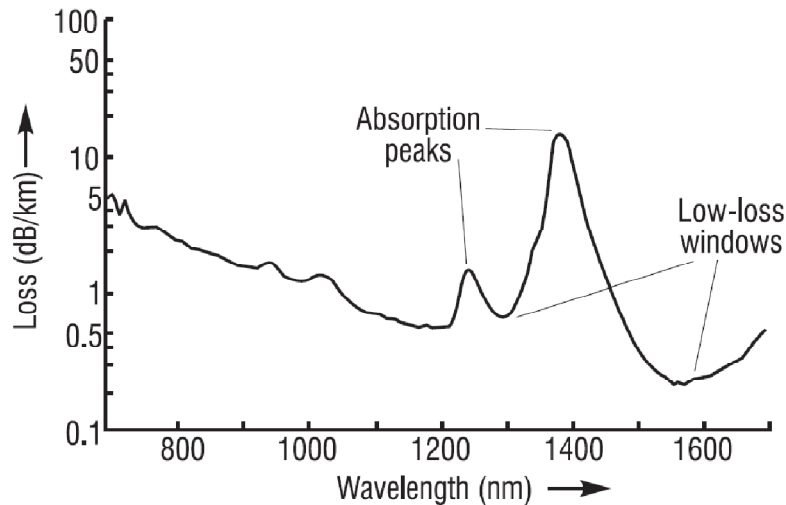

**Figure 5:** *Typical wavelength dependence of attenuation for a silica fiber. Notice that the lowest attenuation occurs at 1550 nm*

As you see, there are two windows at which loss attains its minimum value. The first window is around 1300 nm (with a typical loss coefficient of less than 1 dB/km) where, fortunately (as we will see later), the material dispersion is negligible. However, the loss attains its absolute minimum value of about 0.2 dB/km around 1550 nm. The latter window has become extremely important in view of the availability of erbium-doped fiber amplifiers.

## VII. Types of Optical Fiber:

There are three basic types of fiber optic cable used in communication systems: step-index multimode, step-index single-mode, and graded-index multimode. These are illustrated in Figure 6

### Step-index multimode fiber

Step-index multimode fiber has an index of refraction profile that “steps” from low-to-high-to-low as measured from cladding-to-core-to-cladding. A relatively

large core diameter  $2a$  and numerical aperture N.A. characterize this fiber. The core/cladding diameter of a typical multimode fiber used for telecommunication is  $62.5/125\ \mu\text{m}$  (about the size of a human hair). The term “multimode” refers to the fact that multiple *modes* or *paths* through the fiber are possible, as indicated in Figure 6a. Step-index multimode fiber is used in applications that require high bandwidth ( $< 1\ \text{GHz}$ ) over relatively short distances ( $< 3\ \text{km}$ ) such as a local area network or a campus network backbone.

The major benefits of multimode fiber are:

- (1) It is relatively easy to work with.
- (2) Because of its larger core size, light is easily coupled to and from it.
- (3) It can be used with both lasers and LEDs as sources.
- (4) Coupling losses are less than those of the single-mode fiber.

The drawback is that because many modes are allowed to propagate (a function of core diameter, wavelength, and numerical aperture) it suffers from *intermodal dispersion*, which will be discussed in the next section. Intermodal dispersion limits bandwidth, which translates into lower data rates.

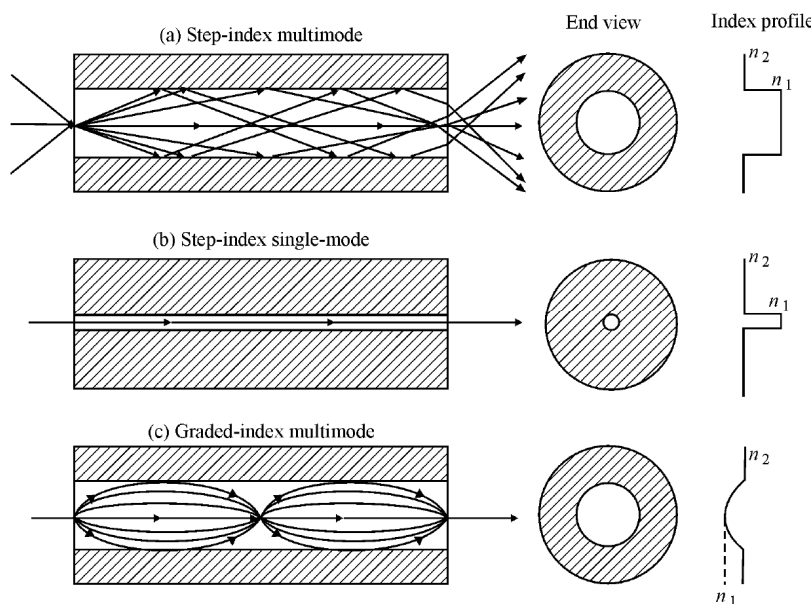

**Figure 6:** *Types of fiber*

### Step-index single-mode fiber

Single-mode step-index fiber (Figure 6b) allows for only one path, or mode, for light to travel within the fiber. In a multimode step-index fiber, the number of modes  $M_n$  propagating can be approximated by

$$M_n = \frac{V^2}{2} \quad \dots \text{(13)}$$

Here  $V$  is known as the normalized frequency, or the  **$V$ -number**, which relates the fiber size, the refractive index, and the wavelength. The  $V$ -number is given by Equation 14.

$$V = \left[ \frac{2\pi a}{\lambda} \right] \times \text{N.A.} \quad \dots \text{(14)}$$

or by Equation 15

$$V = \left[ \frac{2\pi a}{\lambda} \right] \times n_1 \sqrt{2\Delta} \quad \dots \text{(15)}$$

In either equation,  $a$  is the fiber core radius,  $\lambda$  is the operating wavelength, N.A. is the numerical aperture,  $n_1$  is the core index, and  $\Delta$  is the relative refractive index difference between core and cladding.

The analysis of how the  $V$ -number is derived is beyond the scope of this module. But it can be shown that by reducing the diameter of the fiber to a point at which the  $V$ -number is less than 2.405, higher-order modes are effectively extinguished and single-mode operation is possible.

The core diameter for a typical single-mode fiber is between 5 and 10  $\mu\text{m}$  with a 125- $\mu\text{m}$  cladding. Single-mode fibers are used in applications such as long distance

telephone lines, Wide Area Networks (WANs), and cable TV distribution networks where low signal loss and high data rates are required and repeater/amplifier spacing must be maximized. Because single-mode fiber allows only one mode or ray to propagate (the lowest-order mode), it does not suffer from intermodal dispersion like multimode fiber and therefore can be used for higher bandwidth applications. At higher data rates, however, single-mode fiber is affected by *chromatic dispersion*, which causes pulse spreading due to the wavelength dependence on the index of refraction of glass (to be discussed in more detail in the next section). Chromatic dispersion can be overcome by transmitting at a wavelength at which glass has a fairly constant index of refraction (~1300 nm) or by using an optical source such as a **Distributed-Feedback** laser (DFB laser) that has a very narrow output spectrum. The major drawback of single-mode fiber is that compared to step-index multimode fiber, it is relatively difficult to work with (i.e., splicing and termination) because of its small core size and small numerical aperture. Because of the high coupling losses associated with LEDs, single-mode fiber is used primarily with laser diodes as a source.

### **Graded-index fiber**

In a step-index fiber, the refractive index of the core has a constant value. By contrast, in a graded-index fiber, *the refractive index in the core decreases continuously* (in a parabolic fashion) from a maximum value at the center of the core to a constant value at the core-cladding interface. (See Figure 6c.) Graded-index fiber is characterized by its ease of use (i.e., large core diameter and N.A.), similar to a step-index multimode fiber, and its greater information carrying capacity, as in a step-index single-mode fiber. Light traveling through the center of the fiber experiences a higher index of refraction than does light traveling in higher



modes. This means that even though the higher-order modes must travel farther than the lower order modes, they travel faster, thus decreasing the amount of modal dispersion and increasing the bandwidth of the fiber.

### **Polarization-maintaining fiber**

Polarization-maintaining (PM) fiber is a type of fiber that only allows light of a *specific polarization orientation to propagate*. It is often referred to as high birefringence single-mode fiber. (A birefringent material is one in which the refractive index is different for two orthogonal orientations of the light propagating through it.) In birefringent fiber, light polarized in orthogonal directions will travel at different speeds along the polarization axes of the fiber. PM fibers utilize a stress-induced birefringence mechanism to achieve high levels of birefringence. These fibers embed a stress applying region in the cladding area of the fiber. (See Figure 7.) Placed symmetrically about the core, it gives the fiber cross-section two distinct axes of symmetry. The stress region squeezes on the core along one axis, which makes the core birefringent. As a result, the propagation speed is polarization dependent, differing for light polarized along the two orthogonal symmetry axes. Birefringence is the key to polarization-maintaining behavior. Because of the difference in propagation speed, light polarized along one symmetry axis is not efficiently coupled to the other orthogonal polarization—even when the fiber is coiled, twisted or bent. PM fibers can be designed with high stress levels to create birefringence sufficient to resist depolarization under harsh mechanical and thermal operating conditions.

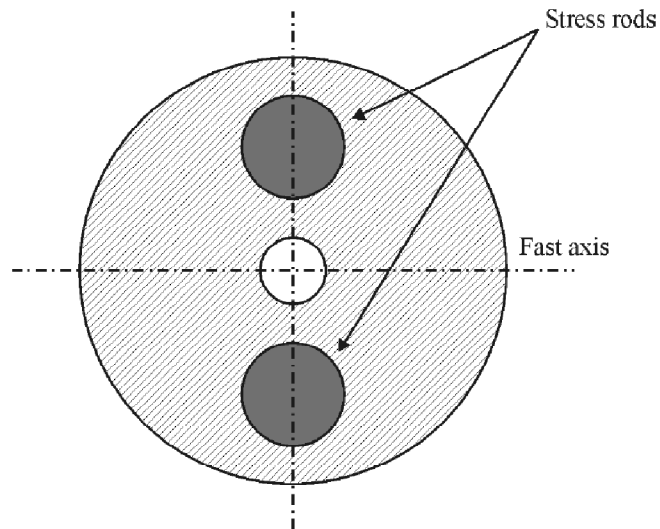

**Figure 7:** *Polarization maintaining fiber*

### **VIII. Dispersion:**

In digital communication systems, information to be sent is first coded in the form of pulses. These pulses of light are then transmitted from the transmitter to the receiver, where the information is decoded. The larger the number of pulses that can be sent per unit time and still be resolvable at the receiver end, the larger will be the transmission capacity, or *bandwidth* of the system. A pulse of light sent into a fiber broadens in time as it propagates through the fiber. This phenomenon is known as *dispersion*, and is illustrated in Figure 8.

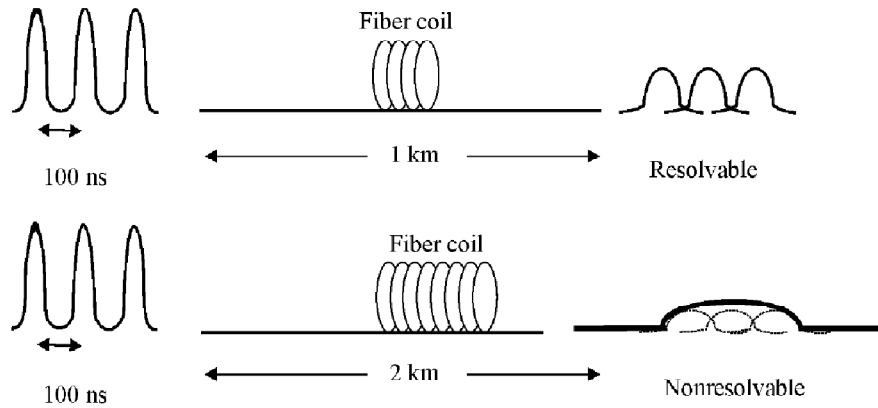

**Figure 8:** Pulses separated by 100 ns at the input end would be resolvable at the output end of 1 km of the fiber. The same pulses would not be resolvable at the output end of 2 km of the same fiber.

**Calculating dispersion:**

Dispersion, termed  $\Delta t$ , is defined as pulse spreading in an optical fiber. As a pulse of light propagates through a fiber, elements such as numerical aperture, core diameter, refractive index profile, wavelength, and laser line-width cause the pulse to broaden. This poses a limitation on the overall bandwidth of the fiber as demonstrated in Figure 9.

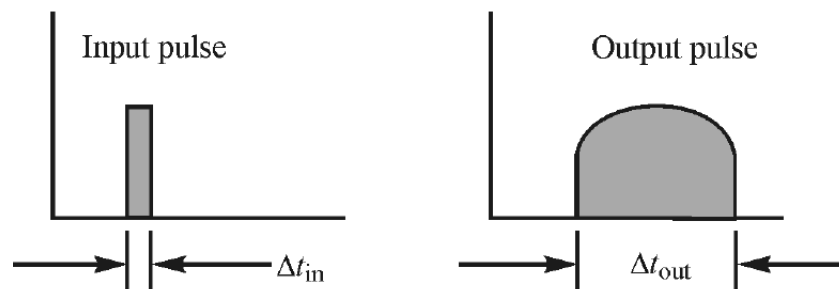

**Figure 9:** Pulse broadening caused by dispersion.

Dispersion  $\Delta t$  can be determined from Equation 16.

$$\Delta t = (\Delta t_{out} - \Delta t_{in})^{1/2} \dots (16)$$

Dispersion is measured in units of time, typically nanoseconds or picoseconds. Total dispersion is a function of fiber length, ergo, the longer the fiber, the more the dispersion. Equation 17 gives the total dispersion per unit length.

$$\Delta t_{\text{total}} = L \times (\text{Dispersion/km}) \quad \dots (17)$$

The overall effect of dispersion on the performance of a fiber optic system is known as *intersymbol interference*, as shown in Figure 9. *Intersymbol interference* occurs when the pulse spreading due to dispersion causes the output pulses of a system to overlap, rendering them undetectable. If an input pulse is caused to spread such that the rate of change of the input exceeds the dispersion limit of the fiber, the output data will become indiscernible.

### Intermodal dispersion:

Intermodal dispersion is the pulse spreading caused by the time delay between lower-order modes (modes or rays propagating straight through the fiber close to the optical axis) and higher-order modes (modes propagating at steeper angles). This is shown in Figure 10. Modal dispersion is problematic in multimode fiber and is the primary cause for bandwidth limitation. It is not a problem in single-mode fiber where only one mode is allowed to propagate.

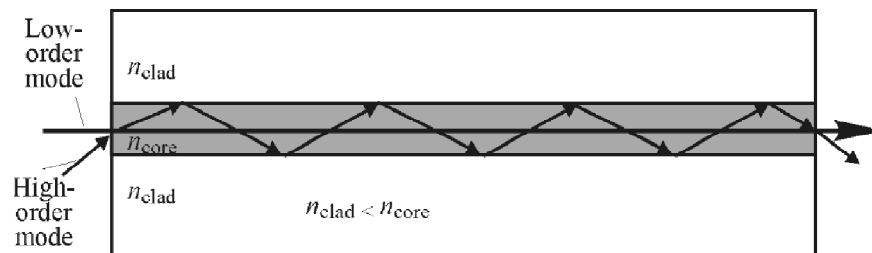

**Figure 10:** Mode propagation in an optical fiber.

**Chromatic dispersion:**

Chromatic dispersion is pulse spreading due to the fact that different wavelengths of light propagate at slightly different speeds through the fiber. All light sources, whether laser or LED, have finite linewidths, which means they emit more than one wavelength. Because the index of refraction of glass fiber is a wavelength-dependent quantity, different wavelengths propagate at different speeds. Chromatic dispersion is typically expressed in units of nanoseconds or picoseconds per (km-nm).

Chromatic dispersion consists of two parts: *material dispersion* and *waveguide dispersion*.

$$\Delta t_{\text{chromatic}} = \Delta t_{\text{material}} + \Delta t_{\text{waveguide}} \quad \dots \text{(18)}$$

*Material dispersion* is due to the wavelength dependency on the index of refraction of glass. *Waveguide dispersion* is due to the physical structure of the waveguide. In a simple step-index profile fiber, waveguide dispersion is not a major factor, but in fibers with more complex index profiles, waveguide dispersion can be more significant. Material dispersion and waveguide dispersion can have opposite signs (or slopes) depending on the transmission wavelength. In the case of a step-index single-mode fiber, these two effectively cancel each other at 1310 nm yielding zero-dispersion, which makes high-bandwidth communication possible at this wavelength. The drawback, however, is that even though dispersion is minimized at 1310 nm, attenuation is not. Glass fiber exhibits minimum attenuation at 1550 nm. Glass exhibits its minimum attenuation at 1550 nm, and optical amplifiers (known as erbium-doped fiber amplifiers [EDFA]) also operate in the 1550-nm range. It makes sense, then, that if the zero dispersion property of 1310 nm could be shifted to coincide with the 1550-nm transmission window, very high-

bandwidth long-distance communication would be possible. With this in mind, *zero-dispersion-shifted fiber* was developed.

*Zero-dispersion-shifted fiber* “shifts” the zero dispersion wavelength of 1310 nm to coincide with the 1550 nm transmission window of glass fiber by modifying the waveguide dispersion slope. Modifying the waveguide dispersion slope is accomplished by modifying the refractive index profile of the fiber in a way that yields a more negative waveguide-dispersion slope. When combined with a positive material dispersion slope, the point at which the sum of two slopes cancel each other out can be shifted to a higher wavelength such as 1550 nm or beyond. (See Figure 11.)

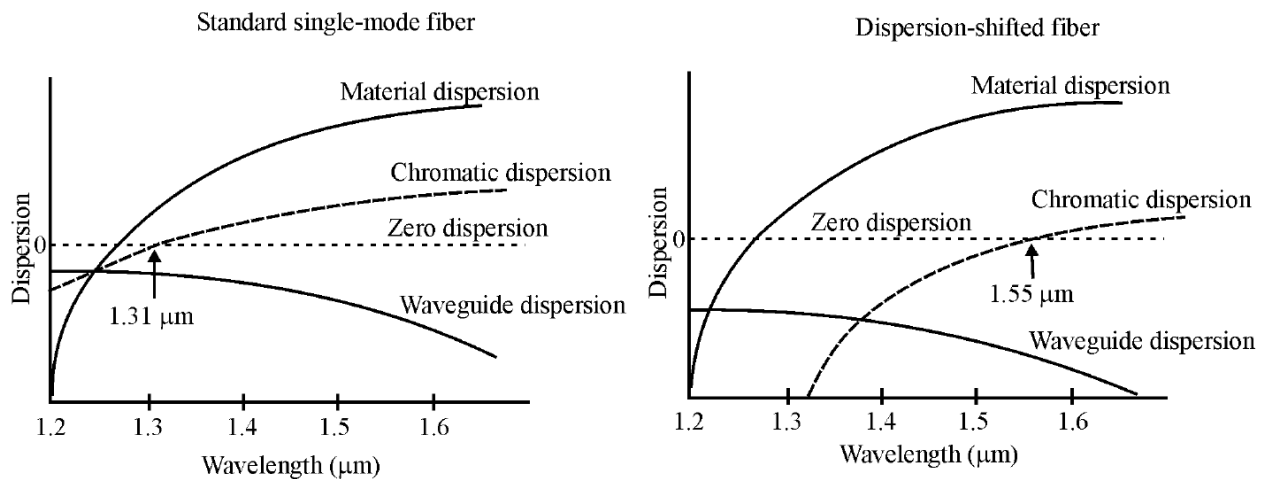

**Figure 11:** *Single-mode versus dispersion-shifted fiber.*

An example of a zero-dispersion-shifted fiber is the “W-profile” fiber, named because of the shape of the refractive index profile which looks like a “W.” This is illustrated in Figure 12. By splicing in short segments of a dispersion-shifted fiber with the appropriate negative slope into a fiber optic system with positive chromatic dispersion, the pulse spreading can be minimized. This results in an increase in data rate capacity.

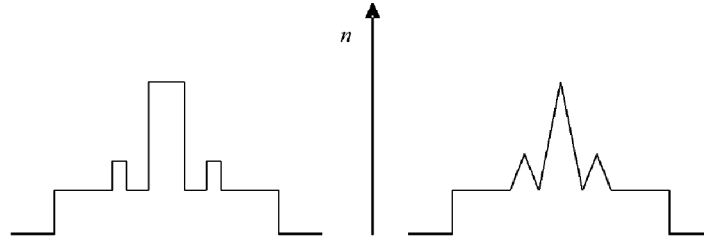

**Figure 12:** *W-profile fibers: (a) step-index, (b) triangular profile.*

In systems where multiple wavelengths are transmitted through the same single-mode fiber, such as in *dense wavelength division multiplexing* (DWDM, discussed in a later section), it is possible for three equally spaced signals transmitted near the specified zero-dispersion wavelength to combine and generate a new fourth wave, which can cause interference between channels. This phenomenon is called *four-wave mixing*, which degrades system performance. If, however, the waveguide structure of the fiber is modified so that the waveguide dispersion is further increased in the negative direction, the zero-dispersion point can be pushed out past 1600 nm (outside the EDFA operating window). This results in a fiber in which total chromatic dispersion is still substantially lower in the 1550 nm range without the threat of performance problems. This type of fiber is known as *nonzero dispersion-shifted fiber*.

The total dispersion of an optical fiber,  $\Delta t_{\text{tot}}$ , can be approximated using

$$\Delta t_{\text{total}} = \sqrt{\Delta t_{\text{modal}}^2 + \Delta t_{\text{chromatic}}^2} \quad \dots \text{(19)}$$

where  $\Delta t_{\text{modal}}$  represents the dispersion due to the various components that make up the system. The transmission capacity of fiber is typically expressed in terms of *bandwidth*  $\times$  *distance*. For example, the (bandwidth  $\times$  distance) product for a typical 62.5/125- $\mu\text{m}$  (core/cladding diameter) multimode fiber operating at 1310 nm might be expressed as 600 MHz  $\cdot$  km.

The approximate bandwidth **BW** of a fiber can be related to the total dispersion by the following relationship:

$$\text{BW (Hz)} = 0.35/\Delta t_{\text{total}} \quad \dots \text{(20)}$$

## **IX. Fiber Optic Cable Design:**

In most applications, optical fiber is protected from the environment by using a variety of different cabling types based on the type of environment in which fiber will be used. Cabling provides the fiber with protection from the elements, added tensile strength for pulling, rigidity for bending, and durability. As fiber is drawn from the preform in the manufacturing process, a protective coating, a UV-curable acrylate, is applied to protect against moisture and to provide mechanical protection during the initial stages of cabling. A secondary buffer then typically encases the optical fibers for further protection.

Fiber optic cable can be separated into two types: *indoor* and *outdoor* cables. (See Table 1.)

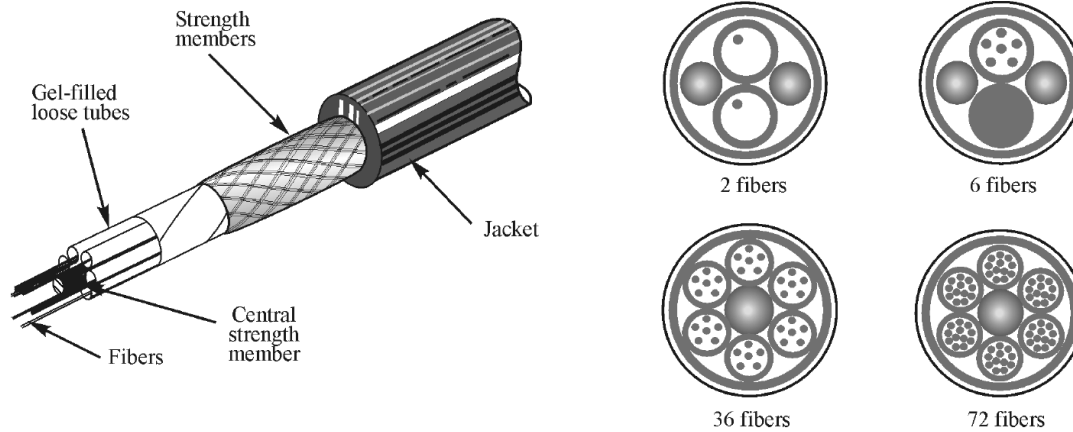

**Table 1:** Indoor and Outdoor Cables.

Indoor Cable	Description
Simplex Cables	Contains a single fiber for one-way communication
Duplex Cables	Contains two fibers for two-way communications
Multifiber Cables	Contains more than two fibers. Fibers are usually in pairs for duplex operation. For example, a twelve-fiber cable permits six duplex circuits.
Breakout Cables	Typically have several individual simplex cables inside an outer jacket. The outer jacket includes a ripcord to allow easy access
Heavy, Light, Plenum-Duty, and Riser Cable	<u>Heavy-duty</u> cables have thicker jackets than <u>light duty cable</u> for rougher handling <u>Plenum cables</u> are jacketed with low-smoke and fire retardant materials <u>Riser cables</u> run vertically between floors and must be engineered to prevent fires from spreading between floors
Outdoor Cables	Outdoor cables must withstand more harsh environment conditions than indoor cables.
Overhead	Cables strung from telephone lines
Direct Burial	Cables placed directly in a trench
Indirect Burial	Cables placed in a conduit
Submarine	Underwater cable, including transoceanic applications

Most telecommunication applications employ either a loose-tube, tight buffer, or ribbon-cable design. *Loose tube cable* is used primarily in outside-plant applications that require high pulling strength, resistance to moisture, large temperature ranges, low attenuation, and protection from other environmental factors. (See Figure 13.) Loose-tube buffer designs allow easy drop-off of groups of fibers at intermediate points. A typical loose-tube cable can hold up to 12 fibers, with a cable capacity of more than 200 fibers. In a loose-tube cable design, color-coded plastic buffer tubes are filled with a gel to provide protection from water and moisture. The fact that the fibers “float” inside the tube provides additional isolation from mechanical stress such as pull force and bending introduced during the installation process. Loose-tube cables can be either all dielectric, or armored. In addition, the buffer tubes are stranded around a dielectric or steel central member which serves as an anti-buckling element. The cable core is typically surrounded by aramid fibers to provide tensile strength to the cable. For additional protection, a medium-density outer polyethylene jacket is extruded over the core.

In armored designs, corrugated steel tape is formed around a single-jacketed cable with an additional jacket extruded over the armor.



**Figure 13:** *Loose tube direct burial cable.*

*Tight buffer cable* is typically used for indoor applications where ease of cable termination and flexibility are more of a concern than low attenuation and environmental stress. (See Figure 14.) In a tight-buffer cable, each fiber is individually buffered (direct contact) with an elastomeric material to provide good impact resistance and flexibility, while keeping size at a minimum. Aramid fiber strength members provide the tensile strength for the cable. This type of cable is suited for “jumper cables”, which typically connect loose-tube cables to active components such as lasers and receivers. Tight-buffer fiber may introduce slightly more attenuation due to the stress placed on the fiber by the buffer. However, because tight-buffer cable is typically used for indoor applications, distances are generally much shorter than for outdoor applications allowing systems to tolerate more attenuation in exchange for other benefits.

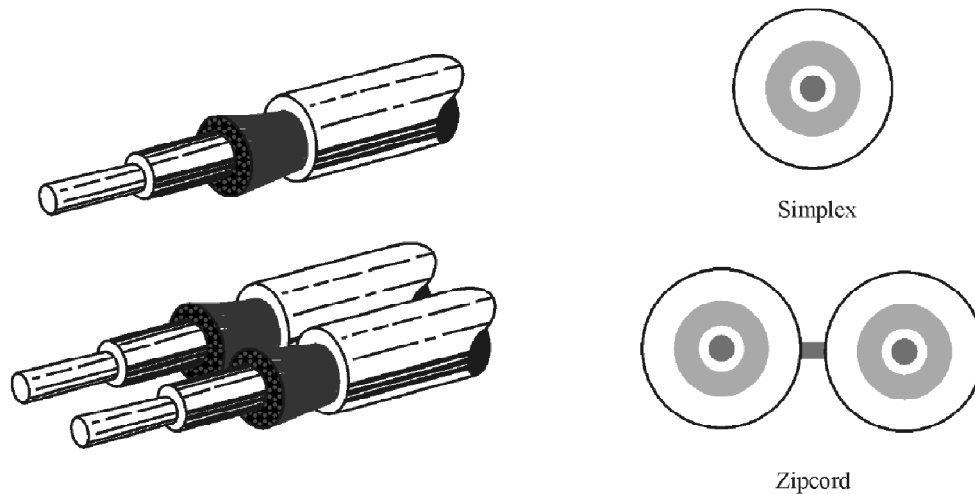

**Figure 14:** *Tight buffer simplex and duplex cable.*

*Ribbon cable* is used in applications where fibers must be densely packed. (See Figure 15.) Ribbon cables typically consist of up to 18-coated fibers that are bonded or laminated to form a ribbon. Many ribbons can then be combined to form a thick, densely packed fiber cable that can be either mass-fusion spliced or terminated using array connectors that can save a considerable amount of time as compared to loose-tube or tight-buffer designs.

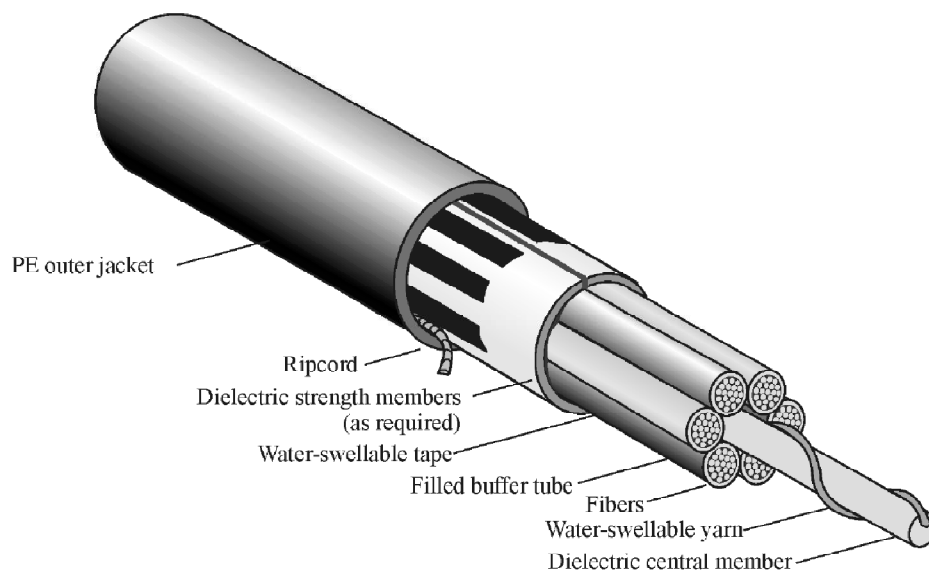

**Figure 15:** *Loose tube ribbon cable.*

Figure 16 shows an example of an interbuilding cabling scenario.

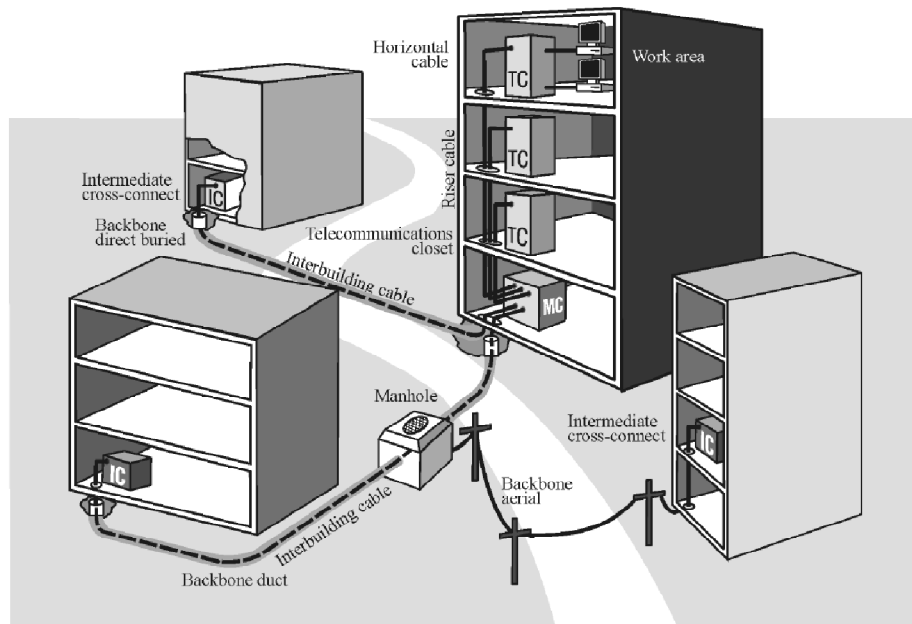

**Figure 16:** *Interbuilding cabling scenario.*

## X. Fiber Optic Sources:

Two types of light sources are commonly used in fiber optic communications systems: *semiconductor laser diodes* (LD) and *light-emitting diodes* (LED). Each device has its own advantages and disadvantages as listed in Table 2.

**Table 2:** LED Versus Laser.

Characteristic	LED	Laser (LD)
Output power	Lower	Higher
Spectral width	Wider	Narrower
Numerical aperture	Larger	Smaller
Speed	Slower	Faster
Cost	Less	More
Ease of operation	Easier	More difficult

Fiber optic sources must operate in the low-loss transmission windows of glass fiber. LEDs are typically used at the 850-nm and 1310-nm transmission wavelengths, whereas lasers are primarily used at 1310 nm and 1550 nm.

### LEDs:

LEDs are typically used in lower-data-rate, shorter-distance multimode systems because of their inherent bandwidth limitations and lower output power. They are used in applications in which data rates are in the hundreds of megahertz as opposed to GHz data rates associated with lasers. Two basic structures for LEDs are used in fiber optic systems: *surface-emitting* and *edge-emitting* as shown in Figure 17.

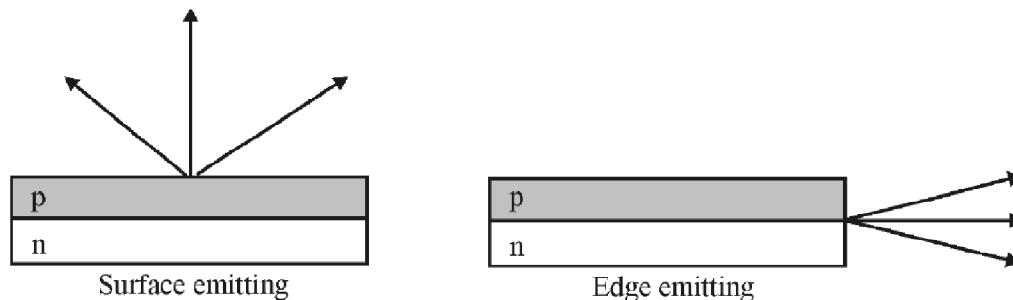

**Figure 17:** *Surface-emitting versus edge-emitting diodes.*

LEDs typically have large numerical apertures, which makes light coupling into single-mode fiber difficult due to the fiber's small N.A. and core diameter. For this reason LEDs are most often used with multimode optical fiber. LEDs are used in lower-data-rate, short-distance (<1 km) multimode systems because of their inherent bandwidth limitations and low output power. In addition, the output spectrum of a typical LED is about 40 nm, which limits its performance due to severe chromatic dispersion. LEDs, however, operate in a more linear fashion than do laser diodes making them more suitable for analog modulation. Most fiber optic light sources are *pigtailed*, having a fiber attached during the manufacturing

process. Some LEDs are available with connector-ready housings that allow a connectorized fiber to be directly attached and are relatively inexpensive compared to laser diodes. LEDs are used in applications including local area networks, closed-circuit TV, and where transmitting electronic data in areas where EMI may be a problem.

### **Laser diodes:**

Laser diodes are used in applications in which longer distances and higher data rates are required. Because an LD has a much higher output power than an LED, it is capable of transmitting information over longer distances. Consequently, and given the fact that the LD has a much narrower spectral width, it can provide high-bandwidth communication over long distances. The LD's smaller N.A. also allows it to be more effectively coupled with single-mode fiber. The difficulty with LDs is that they are inherently nonlinear, which makes analog transmission more difficult. They are also very sensitive to fluctuations in temperature and drive current, which causes their output wavelength to drift. In applications such as wavelength division multiplexing in which several wavelengths are being transmitted down the same fiber, the wavelength stability of the source becomes critical. This usually requires complex circuitry and feedback mechanisms to detect and correct for drifts in wavelength. The benefits, however, of high-speed transmission using LDs typically outweigh the drawbacks and added expense.

In high-speed telecommunications applications, specially designed *single-frequency* diode lasers that operate with an extremely narrow output spectrum (< .01 nm) are required. These are known as *distributed-feedback (DFB)* laser diodes (Figure 18). In DFB lasers, a corrugated structure, or diffraction grating, is fabricated directly in the cavity of the laser, allowing only light of a very specific

wavelength to oscillate. This yields an output wavelength spectrum that is extremely narrow—a characteristic required for dense wavelength division-multiplexing (DWDM) systems in which many closely spaced wavelengths are transmitted through the same fiber. Distributed-feedback lasers are available at fiber optic communication wavelengths between 1300 nm and 1550 nm.

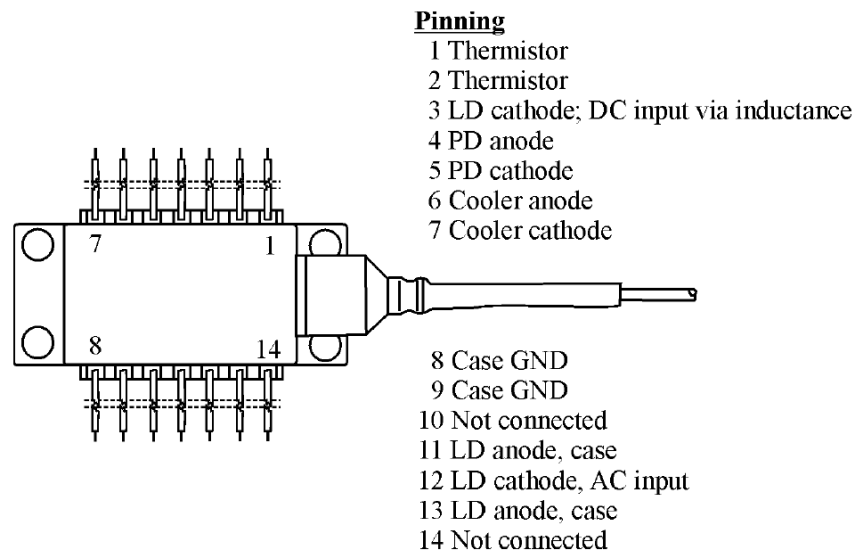

**Figure 18:** *Fourteen-pin butterfly mount distributed feedback laser diode (Source: JDS Uniphase Corporation; used by permission).*

## XI. Fiber Optic Detectors:

The purpose of a fiber optic detector is to convert light emanating from the optical fiber back into an electrical signal. The choice of a fiber optic detector depends on several factors including wavelength, responsivity, and speed or rise time. Figure 19 depicts the various types of detectors and their spectral responses.

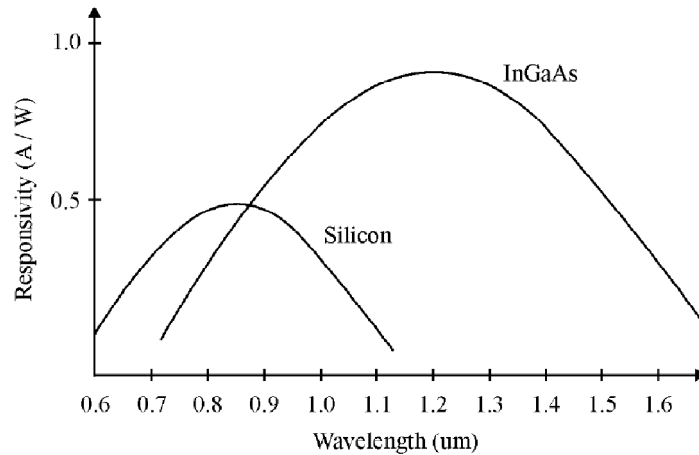

**Figure 19:** *Detector spectral response.*

The most commonly used photodetectors in fiber optic communication systems are the PIN and avalanche photodiodes (APD). The material composition of the device determines the wavelength sensitivity. In general, silicon devices are used for detection in the visible portion of the spectrum. InGaAs crystals are used in the near-infrared portion of the spectrum between 1000 nm and 1700 nm. Germanium PIN and APDs are used between 800 nm and 1500 nm. Table 3 gives some typical photodetector characteristics:

**Table 3:** Typical Photodetector Characteristics.

Photodetector	Wavelength (nm)	Responsivity (A/W)	Dark Current (nA)	Rise Time (ns)
Silicon PIN	250–1100	0.1–1.0	1–10	0.07
InGaAs PIN	1310–1625	0.3–0.85	0.1–1	0.03
InGaAs APD	1310–1625	0.7–1.0	30–200	0.03

Some of the more important detector parameters listed below in Table 4.



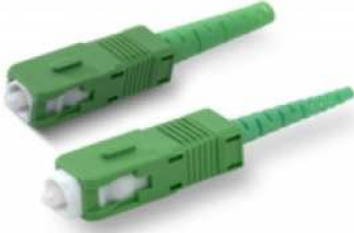



**Table 4: Photodetector Parameters.**

<b>Parameter</b>	<b>Description</b>
<i>Responsivity</i>	The ratio of the electrical power to the detector's output optical power
<i>Quantum efficiency</i>	The ratio of the number of electrons generated by the detector to the number of photons incident on the detector  Quantum efficiency = (Number of electrons)/Photon
<i>Dark current</i>	The amount of current generated by the detector with no light applied. Dark current increases about 10% for each temperature increase of 1°C and is much more prominent in Ge and InGaAs at longer wavelengths than in silicon at shorter wavelengths.
<i>Noise floor</i>	The minimum detectable power that a detector can handle. The noise floor is related to the dark current since the dark current will set the lower limit.  Noise floor = Noise (A)/Responsivity (A/W)
<i>Response Time</i>	The time required for the detector to respond to an optical input. The response time is related to the bandwidth of the detector by  $BW = 0.35/t_r$ where $t_r$ is the rise time of the device. The rise time is the time required for the detector to rise to a value equal to 63.2% of its final steady-state reading.
<i>Noise equivalent power (NEP)</i>	At a given modulation frequency, wavelength, and noise bandwidth, NEP is the incident radiant power that produces a signal-to-noise ratio of one at the output of the detector

**Connectors:**

In the 1980s, there were many different types and manufacturers of *connectors*. Some remain in production, but much of the industry has shifted to standardized connector types, with details specified by standards organizations such as the Telecommunications Industry Association, the International Electro-technical Commission, and the Electronic Industry Association. Today, there are many different types of connectors available for fiber optics depending on the application. Some of the more common types are shown in Table 5:

**Table 5:** Fiber Optic Connector Types.

Type	Description	Diagram
SC	Snap-in Single-Fiber Connector: A square cross section allows high packing density on patch panels and makes it easy to package in a polarized duplex form that assures the fibers are matched to the proper fibers in the mated connector. Used in premise cabling, ATM, fiber-channel, and low-cost FDDI. Available in simplex and duplex configurations.	
ST	Twist-on Single-Fiber Connector: The most widely used and broadly used type of connector for data communications applications. A bayonet-style "twist and lock" coupling mechanism allows for quick connects and disconnects, and a spring-loaded 2.5 mm diameter ferrule for constant contact between mating fibers	
LC	Small Form Factor Connector: Similar to SC connector but designed to reduce system costs and connector density.	
FC	Twist-on Single-Fiber Connector: Similar to the ST connector and used primarily in the telecommunications industry. A threaded coupling and tunable keying allows ferrule to be rotated to minimize coupling loss.	

## XII. Fiber Optic Couplers:

A fiber optic *coupler* is a device used to connect a single (or multiple) fiber to many other separate fibers. There are two general categories of couplers:

- Star couplers (Figure 20a).
- T-couplers (Figure 20b).

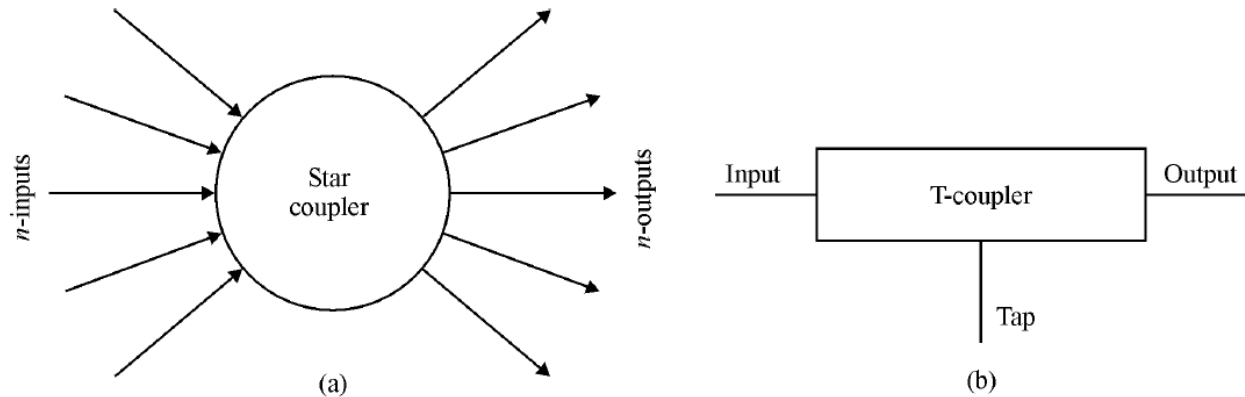

**Figure 20:** (a) Star coupler (b) T-coupler.

### Star couplers:

In a star coupler, each of the optical signals sent into the coupler are available at all of the output fibers (Figure 20a). Power is distributed evenly. For an  $n \times n$  star coupler ( $n$ -inputs and  $n$ -outputs), the power available at each output fiber is  $1/n$  the power of any input fiber. The output power from a star coupler is simply

$$P_o = P_{in}/n \quad \dots (21)$$

where  $n$  = number of output fibers.

The **power division** (or power splitting ratio)  $PD_{st}$  in decibels is given by Equation 22.

$$PD_{st}(\text{dB}) = -10 \log(1/n) \quad \dots (22)$$

The power division in decibels gives the number of decibels apparently lost in the coupler from single input fiber to single fiber output. **Excess power loss** ( $Loss_{ex}$ ) is the power lost from input to *total* output, as given in Equation 23 or 24.

$$Loss_{ex} = \frac{P_{out}(\text{total})}{P_{in}} \quad \dots (23)$$

$$\text{Loss}_{\text{ex/dB}} = -10 \log \frac{P_{\text{out}}(\text{total})}{P_{\text{in}}} \dots (24)$$

### T-couplers:

Figure 21 show a *T-coupler*. Power is launched into port 1 and is then split between ports 2 and 3. The power split does not have to be equal. The power division is given in decibels or in percent. For example, an 80/20 split means 80% to port 2, 20% to port 3. In decibels, this corresponds to 0.97 dB for port 2 and almost 7.0 dB for port 3.

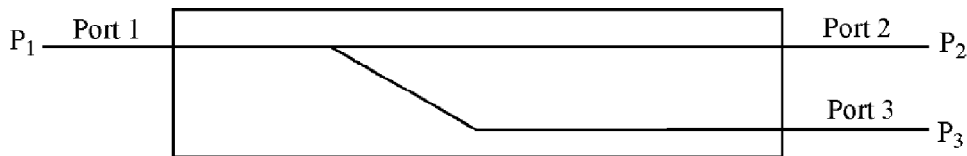

**Figure 21:** *T-coupler*.

$$10 \log (P_2/P_1) = -0.97 \text{ dB}$$

$$10 \log (P_3/P_1) = -6.99 \text{ dB}$$

*Directivity* describes the transmission between the ports. For example, if  $P_3/P_1 = 0.5$ ,  $P_3/P_2$  does not necessarily equal 0.5. For a highly directive T-coupler,  $P_3/P_2$  is very small. That is, no power is transferred between the two ports on the same side of the coupler.